



Güralp 6TD

Operators' Guide

Document Number: MAN-T60-0002

Issue J : March, 2021

Designed and manufactured by
Güralp Systems Limited
3 Midas House, Calleva Park
Aldermaston RG7 8EA
England

Table of Contents

1 Preliminary Notes.....	6
1.1 Proprietary Notice.....	6
1.2 Warnings, Cautions and Notes.....	6
1.3 Manuals and Software.....	6
1.4 Conventions.....	6
2 Introduction.....	7
2.1 State of health information.....	8
2.2 Options.....	8
2.2.1 Storage and interfaces.....	8
2.2.2 Sensor response.....	8
2.2.3 Wireless networking.....	9
3 First encounters.....	11
3.1 Unpacking and packing.....	11
3.1.1 Serial number.....	12
3.2 Test installation.....	12
3.3 Testing several instruments together.....	14
4 Installing the 6TD.....	18
4.1 Handling notes.....	18
4.2 Connections.....	18
4.2.1 The instrument.....	18
4.2.2 The break-out box.....	19
4.3 Installation notes.....	20
4.4 Installing in vaults.....	21
4.5 Installing in pits.....	24
4.6 Other installation methods.....	26
4.7 Rapid installation.....	27
4.8 Recovery.....	30
4.9 Networking overview.....	31

4.10	Setting up the Ethernet interface.....	32
4.10.1	Using DeviceInstaller.....	32
4.10.2	Using DHCP.....	35
4.10.3	Configuration with the Web interface.....	35
4.11	Setting up wireless networking.....	36
4.11.1	Using DeviceInstaller.....	37
4.11.2	Using DHCP.....	39
4.11.3	Configuration with the Web interface.....	40
4.11.4	Installing wireless hardware.....	42
4.12	Configuring the built-in digitiser.....	43

5 Accessing data.....44

5.1	Receiving data in Scream!.....	45
5.2	Downloading data over FireWire.....	46
5.3	Reading 6TD disks.....	47
5.4	Downloading recorded data over the serial port or Ethernet interface.....	50

6 Configuration with Scream!.....53

6.1	Configuring the digitiser.....	53
6.1.1	System ID.....	54
6.1.2	Output control.....	55
6.1.3	Triggering.....	56
6.1.4	Mux Channels.....	61
6.1.5	Ports.....	62
6.2	Controlling the instrument.....	63
6.2.1	System.....	64
6.2.2	Triggering.....	65
6.2.3	Calibration.....	65
6.2.4	Data flow.....	66
6.2.5	Transmission mode commands.....	68
6.2.6	Buffering mode commands.....	71
6.3	Digitiser status streams.....	72
6.3.1	GPS.....	72

7 Calibrating the 6TD.....74

7.1	The calibration pack.....	74
7.2	Poles and zeroes.....	74
7.3	Frequency response curves.....	76
7.4	Obtaining copies of the calibration pack.....	76
7.5	Calibration methods.....	77
7.5.1	Noise calibration with Scream!.....	77
7.5.2	Sensor response codes.....	80

7.6 The coil constant.....	80
----------------------------	----

8 Command-line interface.....	82
8.1 FORTH.....	82
8.2 General configuration.....	83
8.2.1 SET-ID.....	83
8.2.2 BAUD.....	83
8.2.3 LOAD.....	84
8.2.4 LOAD-I.....	84
8.2.5 TEMP?.....	85
8.2.6 ETHER.....	85
8.3 GPS and timing systems.....	85
8.3.1 GPS-TYPE.....	85
8.3.2 HR-CYCLE.....	85
8.3.3 XGPS.....	86
8.3.4 SET-RTC.....	86
8.3.5 SET-CLOCK.....	86
8.3.6 TIME?.....	86
8.3.7 .FIX.....	87
8.3.8 .POSITION.....	87
8.3.9 LEAPSECOND.....	88
8.3.10 SQPATCH.....	88
8.4 Output configuration.....	88
8.4.1 SAMPLES/SEC.....	88
8.4.2 SET-TAPS.....	89
8.4.3 COMPRESSION.....	89
8.4.4 ETHER.....	90
8.4.5 MS-GAP.....	90
8.5 Triggering.....	91
8.5.1 TRIGGERS.....	91
8.5.2 TRIGGERED.....	91
8.5.3 STA.....	91
8.5.4 LTA.....	92
8.5.5 RATIOS.....	92
8.5.6 BANDPASS.....	92
8.5.7 PRE-TRIG.....	93
8.5.8 POST-TRIG.....	93
8.5.9 TRIGGERIN.....	93
8.5.10 TRIGGEROUT.....	93
8.6 Calibration.....	94
8.6.1 SINEWAVE.....	94
8.6.2 SQUAREWAVE.....	94
8.6.3 RANDOMCAL.....	94
8.6.4 MINUTE.....	95
8.6.5 %AMPLITUDE.....	95
8.7 Actions.....	95

8.7.1	RESP.....	95
8.7.2	MASSES?.....	95
8.7.3	RE-BOOT.....	96
8.8	Flash storage and filing.....	96
8.8.1	SHOW-FLASH.....	96
8.8.2	DOWNLOAD.....	96
8.8.3	FROM-TIME.....	97
8.8.4	TO-TIME.....	97
8.8.5	ALL-TIMES.....	98
8.8.6	ALL-FLASH.....	98
8.8.7	ALL-DATA.....	98
8.8.8	STREAM.....	98
8.8.9	STATUS-ONLY.....	99
8.8.10	S/S.....	99
8.8.11	FLUSH.....	99
8.8.12	FLUSHALL.....	99
8.8.13	RESET-DISK.....	99
8.8.14	DIR.....	100
8.8.15	RESET-FLASH.....	100
8.8.16	ERASEFILE.....	101

9 Updating the 6TD firmware.....102

10 Connector pin-outs.....104

10.1	Instrument connectors.....	104
10.1.1	Instrument output port.....	104
10.1.2	Instrument <i>FIREWIRE</i> port.....	105
10.1.3	Instrument <i>ETHERNET</i> port.....	106
10.1.4	Instrument Wi-Fi antenna connection.....	107
10.2	Breakout box connectors.....	108
10.2.1	Breakout box data port.....	108
10.2.2	Breakout box GPS port.....	109
10.2.3	Breakout box power port.....	110

11 Specifications.....111

12 Revision history.....112

1 Preliminary Notes

1.1 Proprietary Notice

The information in this document is proprietary to Güralp Systems Limited and may be copied or distributed for educational and academic purposes but may not be used commercially without permission.

Whilst every effort is made to ensure the accuracy, completeness and usefulness of the information in the document, neither Güralp Systems Limited nor any employee assumes responsibility or is liable for any incidental or consequential damages resulting from the use of this document.

1.2 Warnings, Cautions and Notes

Warnings, cautions and notes are displayed and defined as follows:



Caution: A yellow triangle indicates a chance of damage to or failure of the equipment if the caution is not heeded.



Note: A blue circle indicates indicates a procedural or advisory note.

1.3 Manuals and Software

All manuals and software referred to in this document are available from the Güralp Systems website: www.guralp.com unless otherwise stated.

1.4 Conventions

Throughout this manual, examples are given of command-line interactions. In these examples, a fixed-width typeface will be used:

`Example of the fixed-width typeface used.`

Commands that you are required to type will be shown in bold:

Example of the fixed-width, bold typeface.

Where data that you type may vary depending on your individual configuration, such as parameters to commands, these data are additionally shown in italics:

Example of the fixed-width, bold, italic typeface.

Putting these together into a single example:

System prompt: **user input with variable parameters**

2 Introduction

The Güralp 6TD is an ultra-lightweight digital three-axis seismometer consisting of three sensors in a sealed case, which can measure the north/south, east/west and vertical components of ground motion simultaneously. Each sensor is sensitive to ground vibrations over a wide frequency range (0.033 – 50 Hertz as standard). This frequency response is made possible by advanced force-balance feedback electronics. A built-in 24-bit digitiser converts ground movements to digital data at source with maximum fidelity.

The 6TD has a rugged, waterproof design for ease of installation, and requires no levelling or centring as long as its base is within 3° from the horizontal. For the best results, however, you should install where possible on a hard, near-horizontal surface well coupled to the bedrock.

Once it is provided with 10 – 28 V power the 6TD will begin operating automatically, measuring and digitizing ground movements and either outputting them to your own recording system, or saving them into internal flash memory. Stored data can be retrieved over a FireWire link to an optional, portable disk drive. Accurate timing information can be taken from a GPS unit connected to the 6TD through a breakout box. Both breakout box and GPS are normally supplied with the instrument.



Each seismometer is delivered with a detailed calibration sheet showing its serial number, measured frequency response in both the long period and the short period sections of the seismic spectrum, sensor DC calibration levels, and the transfer function in poles/zeros notation.

6TD sensors can be delivered in sets of five with GPS and cabling included. Each set is supplied in a “smart” case allowing you to huddle-test the sensors without needing to unpack them.



2.1 State of health information

The 6TD constantly monitors the status of the GPS and timing systems, outputting information in a plain text status stream.

An electronic thermometer also provides regular measurements of the sensor's internal temperature, which are reported in the same stream. The thermometer is calibrated to an accuracy up to ± 0.33 °C, with a linearity of ± 0.5 °C.

2.2 Options

2.2.1 Storage and interfaces

The 6TD can be supplied with up to 16 Gb of internal Flash memory for data storage. The amount you need will depend on the length of your experiment and the sampling rates used.

You can download data from the internal storage:

- over a fast IEEE.1394 (FireWire) link with optional power;
- using an optional “smart” case, over USB from up to five units at once (see section 3.3 on page 14);
- over the sensor's standard RS232 data port (compatible with Scream! and other Güralp data modules), (although the speed of transfer is limited by the speed of the serial port); or
- if fitted, using the Ethernet interface to transfer data over a local area network (but see the following note).



Note: Transfer of stored data over both the serial port and the Ethernet interface is **significantly slower** than transfer using the FireWire interface. The use of FireWire is **always** recommended.



Note: When calculating storage requirements, allow at least 50 MB per day of triaxial, 100 sample-per-second data. This figure scales linearly with sample rate so, for example, allow 100 MB per day for 200 sample-per-second data.

2.2.2 Sensor response

The 6TD can be supplied with a response which is flat to velocity from 100 Hertz to any of 1 Hertz, 0.1 Hertz (10 seconds) or 0.033 Hertz (30 seconds).

If you do not require high-frequency data, a low-pass digital filter may be installed at a frequency (below 100 Hertz) that you specify.

2.2.3 Wireless networking

The sensor can be fitted with an optional 802.11b (“Wi-Fi”) wireless interface in addition to the Ethernet port. This option allows data flow to be established from autonomous installations with a minimum of setting up.

For temporary deployments, instruments can be buried in shallow pits with only the antenna above ground. You can then contact each station from a wireless-enabled PC running Scream! without disturbing the instrument, including monitoring real-time data and configuring the digitiser.

More permanent arrays also benefit from wireless technology, particularly in remote areas or where the terrain makes long cable runs impractical.

For example, stations might be installed with high-gain antennae directed towards a visible natural feature which is easier to access.

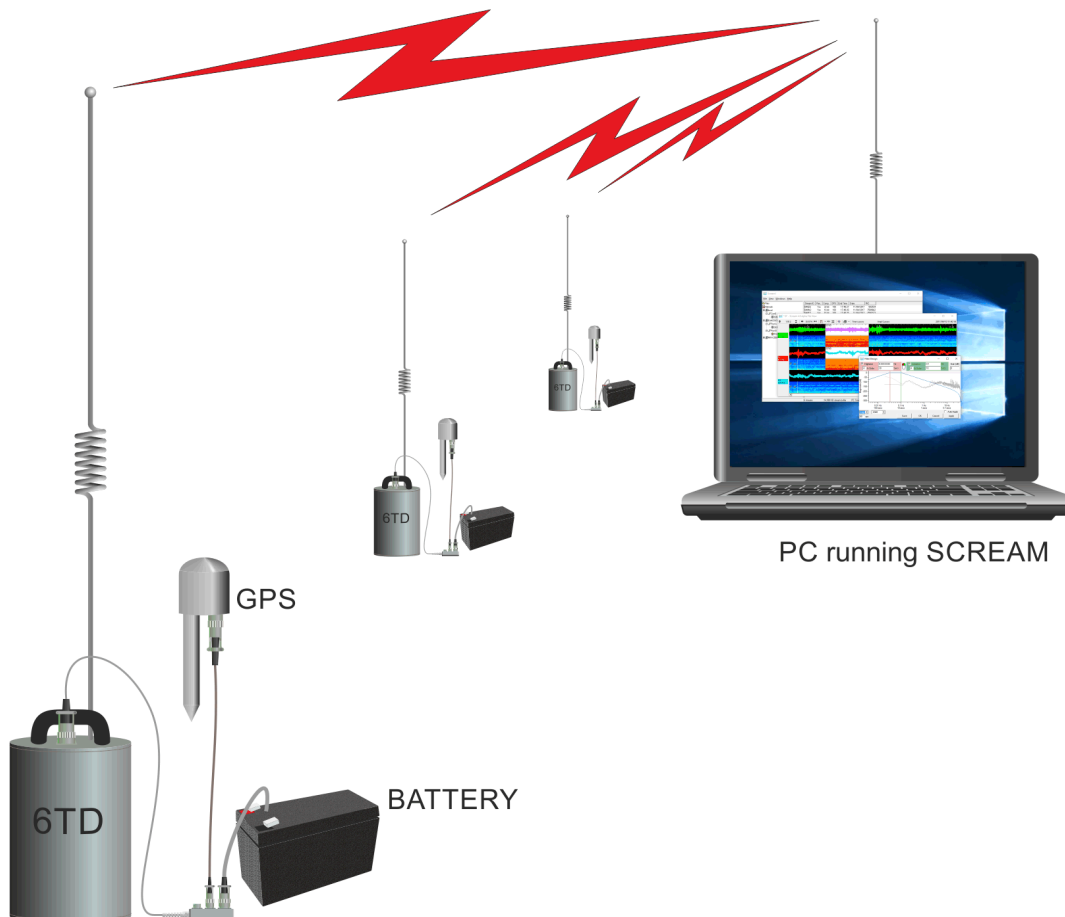

At this location, which can be up to 500 metres away, a low-power EAM data module might act as a “store and forward” point for the array elements and pass the data on to a higher-bandwidth radio link.

In semi-permanent arrays, a wireless-enabled laptop PC can be set up as a temporary access point for the duration of a site visit.

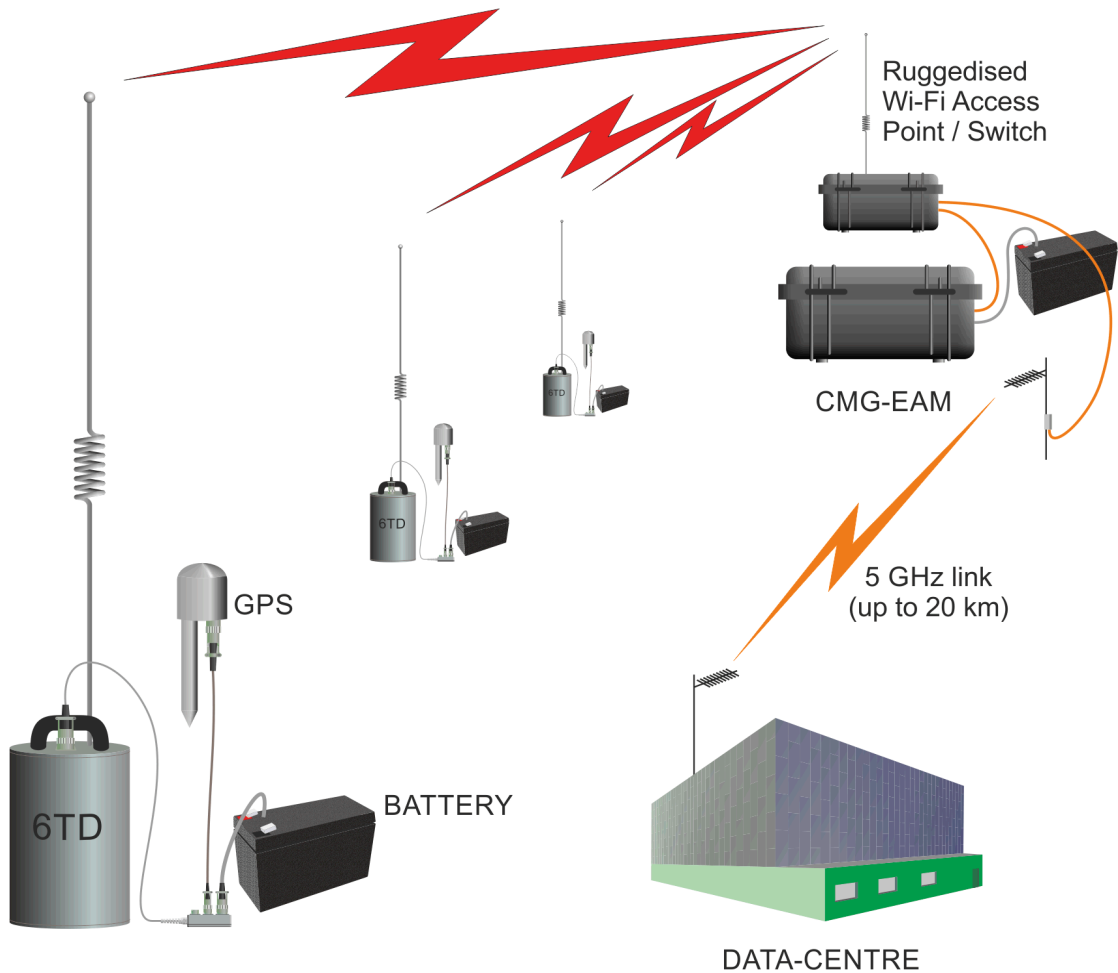

Note: The PC in this example has been configured to act as a wireless access point (AP). There are many different ways to achieve this, depending on the operating system installed, and a full discussion of this technique is beyond the scope of this manual.

3 First encounters

3.1 Unpacking and packing

The 6TD seismometer is delivered in a single transportation case. The packaging is specifically designed for the 6TD and should be reused whenever you need to transport the sensor. Please note any damage to the packaging when you receive the equipment, and unpack on a safe, clean surface. For each instrument in the packaging, you should have received:

- the seismometer;
- the breakout box (which provides separate connections for the signal, control and power lines);
- a Güralp GPS receiver unit with mounting rod;
- a waterproof IEEE.1394 (FireWire) cable;
- a 15 metre GPS cable, with six-pin bayonet connectors at both ends;
- a power supply cable, with bare wires at one end and a ten-pin bayonet socket at the other;
- a serial data cable, with a standard nine-pin D connector at one end and a ten-pin bayonet plug at the other; and
- a calibration and installation sheet.

If you have ordered several instruments with a “smart” case, you can test them together using power and data distribution units inside the case: see section 3.3 on page 14.

Assuming all the parts are present, stand the seismometer in the centre of a bench and identify its external features:

- a handle with North indication,
- a nineteen-way bayonet plug for data, power and GPS signals;
- a six-way bayonet plug for the FireWire interface;
- if fitted, a six-way bayonet plug for the Ethernet interface;
- if fitted, an antenna connector for the Wi-Fi interface;
- a spirit level,
- three feet (two adjustable, and one fixed), and
- two accurate orientation pins (one brass and one steel).

If the Ethernet interface is fitted, you will also be supplied with a Lantronix configuration cable (part number CAS-PEP-0041).

If the Wi-Fi interface is fitted, you will also be supplied with a small aerial for testing purposes and a Lantronix configuration cable (part number CAS-PEP-0041).

3.1.1 Serial number

The sensor's serial number can be found on the label stuck to the top lid of the sensor. You should quote this serial number if you need assistance from Güralp Systems.

3.2 Test installation

This section gives an overview of how to set up a 6TD and begin recording data. We recommend that you set up a test instrument in your office or laboratory as a “dry run” to gain a basic understanding of the system and to check that it is functioning as expected.

This test installation will use the instrument's default settings. Data will be received using Güralp Systems' Scream! software, available from the website

<http://www.guralp.com/>

You will need access to a PC with a nine-pin RS232 port, and a 10 to 28 Volt DC power source. If your PC does not have an RS232 port, you can use an RS232 to USB convert cable. Güralp recommend convertors based on the FTDI chip-set.

1. Install Scream! on your PC and run it.
2. Connect the captive cable from the breakout box to the 6TD's nineteen-pin connector.
3. Connect the six-pin connector on the breakout box to the GPS unit using the brown GPS cable. Position the GPS so that it has a good view of the sky.

If you do not have a view of the sky, you can operate the sensor without a GPS unit but timing information will be inaccurate.

4. Connect the six-pin data plug on the breakout box to the nine-pin RS232 port on your PC using the serial cable. If your PC does not have a nine-pin COM port, use an RS232/USB converter. Güralp Systems recommend converters based on the FTDI chip-set.
5. Use the power cable to connect the ten-pin power plug on the breakout box to a fused 10 – 28 Volt DC power source.



Caution: Observe the correct polarity when connecting the power supply. The **red** lead must be connected to the **positive terminal**, typically labelled '+', and the **black** lead must be connected to the **negative terminal**, typically labelled '-'. An incorrect connection risks destroying both the instrument and the power supply.

The instrument is now fully operational, and will already be producing data.

6. After a few seconds you should see the 6TD's digitiser appear under **Network** → **Local** → **Com1** in the left-hand panel of Scream!'s main window. (If your PC has multiple serial ports, it may appear under some other COM port name.) Soon after, data streams will begin appearing in the right-hand panel. Streams with higher sample rates will appear sooner than those with lower sample rates.

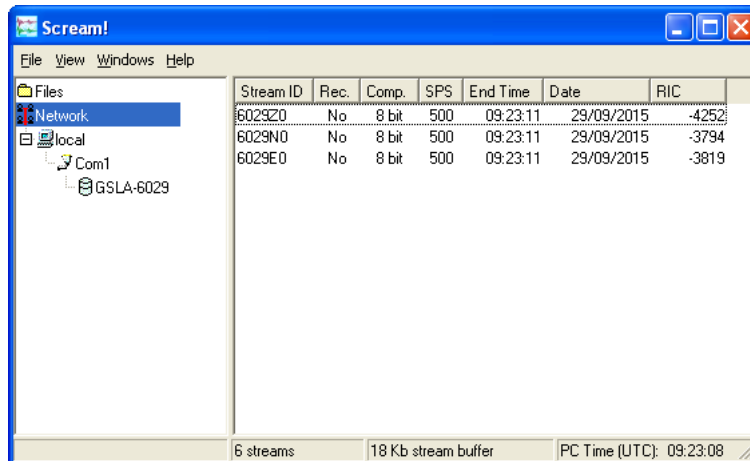

If this does not happen, check all connections, and ensure the power supply is providing the correct voltage and current.

7. Each data stream has a **Stream ID**, a six-character string unique to it. Stream IDs normally identify the instrument, component and sample rate of each stream. Thus the stream 1026Z2 refers to a Z-component stream from instrument 1026, at tap 2. For more details on taps and sample rates, see section 4.1 on page 18.

Data streams ending in 00 are status streams containing state-of-health information sent from the digitiser.

8. To view data, select a stream and then double-click to open a **WaveView** window.

You can view several streams at once by holding down  as you select, and then double-clicking the selection.

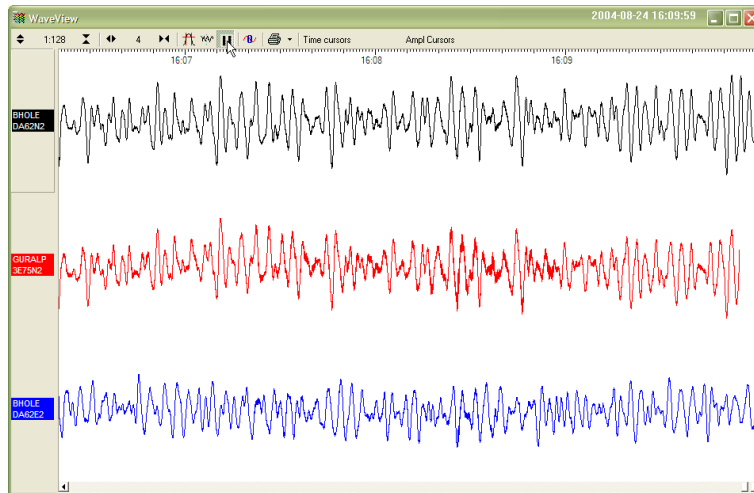

9. To start recording new data to a file, right-click on a stream or a selection of streams and choose **Start recording** from the pop-up menu. Recording settings, directories, etc., can be altered by selecting **File → Setup...** from the main menu and switching to the **Recording** tab.
10. To view status information, select the status stream (the stream with an ID ending "00") and right-click to open a pop-up menu. Select **View**.

```

Status - W3420-659100
02/10/2006 14:41:21
2006 10 02 14:40:32 GPS Power On Continuous
Guralp Systems Ltd - DM32-6X \ v.243
W3420 659100 CMG-6
W3420 659100 CMG-6 33rd System re-boot at 2006 10 02 14:41:21
INTERNAL ID FFFFFFFF
FILESTORE C 00000F0F0F0300FF
FILESTORE K 4188128
FILESTORE P 001006CB
02/10/2006 14:41:30
Last Flush : 000000E2 2006 09 18 11:10:25
No GPS
02/10/2006 14:41:41
N00000001
N00000001
No disk found
2006 10 02 14:41:40 GPS Power On Continuous
02/10/2006 14:43:27
N00000001
N00000001
No disk found
2006 10 02 14:43:26 GPS Power On Continuous

```

The first few status blocks will consist of the 6TD's start-up messages, including its software revision number and the data streams selected for downloading and triggering.

Later blocks give information on the GPS system (number of satellites visible, the location of the GPS antenna, time synchronization status, etc.) and the baud rates in use for each channel.

3.3 Testing several instruments together

6TD instruments can be ordered in sets of five, with each set delivered in a single, rigid polyurethane transport case.



The sensors are packed so that you can huddle-test the sensors and view data in Scream! without needing to unpack them. The case includes a built-in power distribution system, a multi-port serial-to-USB hub and a FireWire hub.

The power and data distribution boxes are located at the front of the case.

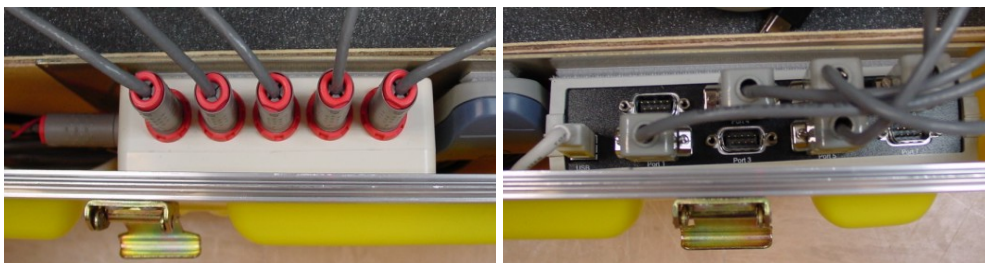

The power supply and combined USB data output cables can be accessed through a waterproof port on the outside of the case.



To test the instruments:

1. Connect a break-out box to each instrument.

2. Connect a blue serial cable from each break-out box to the multi-port serial-to-USB hub.
3. Connect a grey power cable from each break-out box to the power distribution box.
4. If desired, connect the GPS receivers to the break-out boxes using the brown GPS cables.
5. Unscrew the port cover, and pull out the ends of the power and USB cables.



6. Connect the power cable to your power source, attaching a suitable connector, if necessary.
7. Connect the USB data cable to your PC.

The internal Digi EdgePort device should be detected automatically. If you need drivers, they can be obtained from Digi International's web site at <http://www.digi.com>.

8. Install Scream! on your PC and run it.
9. After a few seconds you should see the 6TD's digitiser appear under **Network** → **Local** → **Com1** in the left-hand panel of Scream!'s main window.. (If your PC has multiple serial and USB ports, it may appear under some other **Comn** port name.) Soon after, data streams will begin appearing in the right-hand panel. Streams with higher sample rates will appear sooner than those with lower sample rates.

If this does not happen, check that the the power supply is providing the correct voltage.

- To view data, select the stream or streams of interest and then double-click to open a **WaveView** window.

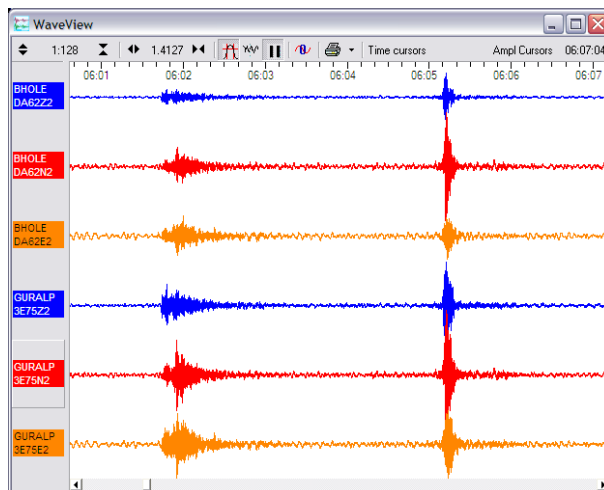

You can also add data streams to an open WaveView window by dragging a selection onto it from Scream!'s main window.

- In addition to the power and USB data distribution units, the case includes a IEEE.1394 ("FireWire") hub for you to test high speed data transfer. To do this, connect a FireWire cable from each instrument to the hub.

Once the instruments are connected, you can access them all through the FireWire data cable, which is accessible through the waterproof port in the side of the case.

- To download all stored data from the array when it is stored in its transport case, attach a FireWire hard disk to this cable and power up the array using the power cable from the same port.

Be sure to allow enough time for all the data to transfer. The 6TD should be able to transfer data at a sustained rate of around 10 Mb per second, so a full 8 Gb 6TD instrument should take around 12 minutes to transfer all its data.



Note: Some combinations of 6TD and disk hardware cannot support the connection of multiple instruments to a single disk. If you encounter problems like this, connect each instrument individually until the transfers have been accomplished.

4 Installing the 6TD

4.1 Handling notes



Caution: Although it has a rugged design, the 6TD is still a sensitive instrument, and is easily damaged if mishandled. If you are at all unsure about the handling or installation of the device, you should contact Güralp Systems for assistance.

Observe the following precautions:

- Do not bump or jolt the sensor when handling or unpacking.
- Do not kink or walk on the data cable (especially on rough surfaces such as gravel), nor allow it to bear the weight of the sensor.
- Move the instrument with care, and report any sign of loose components or parts moving inside the instrument to Güralp Systems.
- Do not connect the instrument to power sources except where instructed.



Caution: Observe the correct polarity when connecting the power supply. The **red** lead must be connected to the **positive terminal**, typically labelled '+', and the **black** lead must be connected to the **negative terminal**, typically labelled '-'. An incorrect connection risks destroying both the instrument and the power supply.

- Do not ground any of the signal lines from the sensor.



Note: All parts of the 6TD are waterproof.

4.2 Connections

4.2.1 The instrument

The 6TD's output connectors are all located on the sensor lid. The sensor can be supplied with a number of options, so not all of the connectors described here may be present on your instrument.

All 6TD instruments have a nineteen-pin bayonet connector which carries power, data and GPS signals. The supplied breakout box (see below) provides individual connectors for these, or you can make up your own cable if you prefer.

The 6TD may also have connectors for the FireWire, Ethernet and/or Wi-Fi interfaces.

The connectors for the FireWire and Ethernet options are both six-pin bayonet plugs. If the labelling has become illegible for any reason, they can be distinguished by noting that the FireWire connector lies to the East of the instrument and the Ethernet connector to the North-East, as in the picture below (which shows an early, unlabelled prototype unit).



4.2.2 The break-out box



In addition to the cable to the instrument, which is moulded into the case, the breakout box provides

- a six-pin bayonet socket for connecting the supplied GPS unit;
- a ten-pin bayonet plug for connecting to a PC's serial interface or a Güralp data module; and
- a six-pin bayonet plug for connecting a DC power supply.

You may need to attach a suitable connector to the power cable provided. The 6TD draws a nominal current of 75 mA from a 12 V supply when in use. A 12 V, 25 Ah

heavy-duty sealed lead-acid battery will, therefore, operate the instrument for around a week without recharging.

4.3 Installation notes

For the best possible results, a seismometer should be installed on a seismic pier in a specially-built vault, where conditions are near perfect. Here, wave-trains arriving at the instrument reflect very well the internal motion of subsurface rock formations. However, this is not always feasible. For example,

- instruments may need to be deployed rapidly, perhaps to monitor the activity of a volcano showing signs of rejuvenation, or to study the aftershocks of a major earthquake;
- installations may be required in remote locations, or otherwise in circumstances where it is not practical to build a vault.

In these situations, the seismometer and its emplacement need to be considered as a mechanical system, which will have its own vibrational modes and resonances. These frequencies should be raised as high as possible so that they do not interfere with true ground motion: ideally, beyond the range of the instrument. This is done by

- standing the sensor on bedrock where possible, or at least deep in well-compacted subsoil;
- clearing the floor of the hole of all loose material; and
- using as little extra mass as possible in preparing the chamber.

In temporary installations, environmental factors are also important. The sensor needs to be well protected against

- fluctuations in temperature,
- turbulent air flow around walls or trees, or around sharp corners or edges in the immediate vicinity of the sensor;
- vibration caused by heavy machinery (even at a distance), or by overhead power lines.

This can be done by selecting a suitable site, and placing the instrument in a protective enclosure. An open-sided box of 5 cm expanded polystyrene slabs, placed over the instrument and taped down to exclude draughts, makes an excellent thermal shield.

After installation, the instrument case and mounting surface will slowly return to the local temperature, and settle in their positions. This will take around four hours from the time installation is completed.

4.4 Installing in vaults

You can install a 6TD in an existing seismic vault with the following procedure:

1. Unpack the sensors from their container, saving the shipping boxes for later transportation.
2. Prepare the mounting surface, which should be smooth and free of cracks. Remove any loose particles or dust, and any pieces of loose surfacing. This ensures good contact between the instrument's feet and the surface.
3. If it is not already present, inscribe an accurate North-South line on the mounting surface.
4. Place the sensor over the scribed line, so that the brass and steel pointers are aligned with the marked directions, with the brass pointer facing North. This can be done by rotating the base of the sensor whilst observing it from above. The brass pointer can be found next to one of the feet.

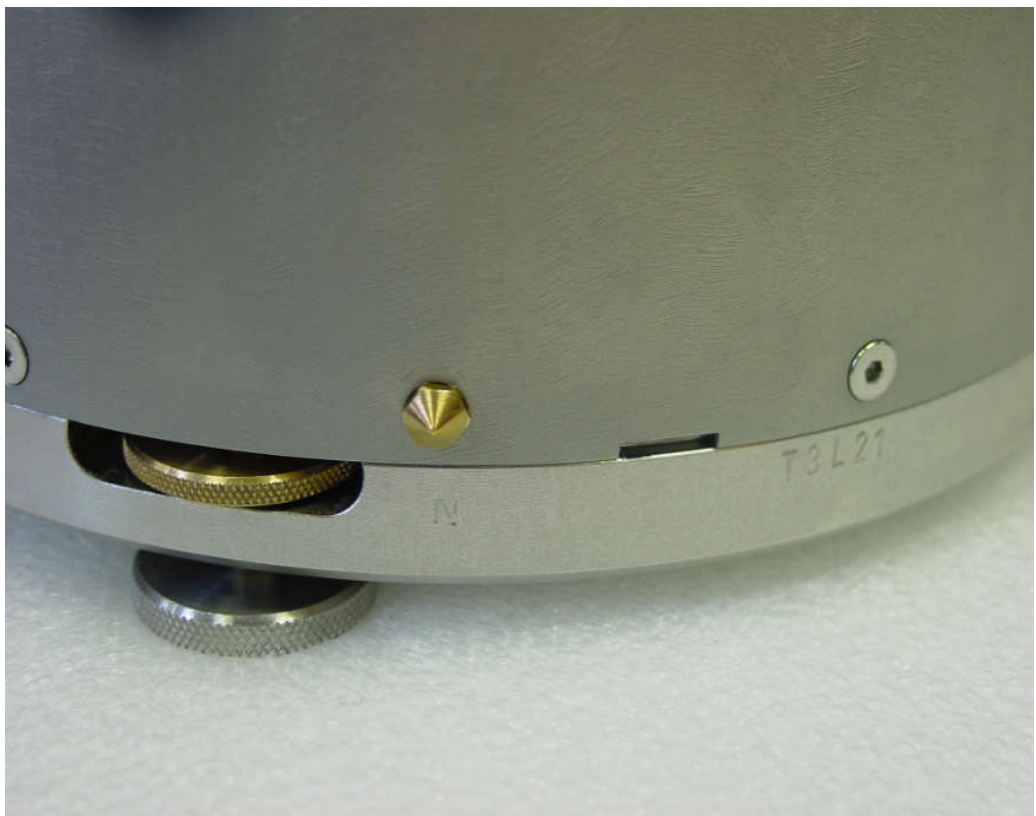

If you cannot easily see the pointers, you should align the sensor using the north arrow on the handle. However, the alignment of the handle with the sensors inside is less accurate than the metal pointers, so they should be used wherever possible.

5. The top panel of the 6TD includes a spirit level.

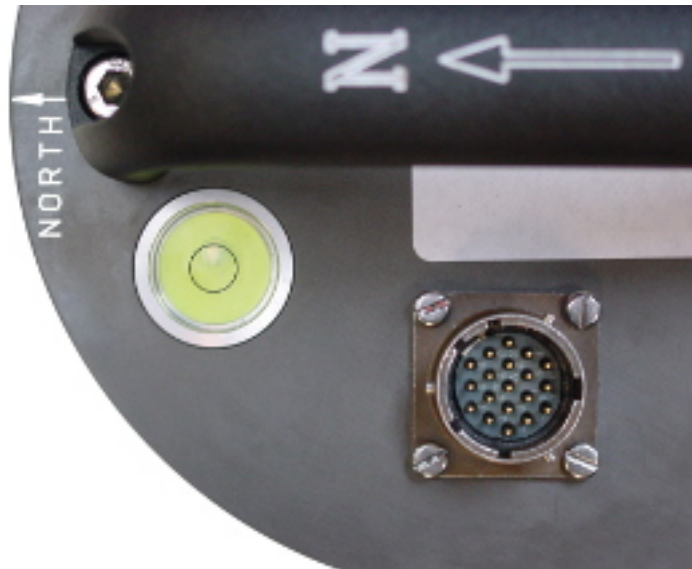

Level the sensor using each of the adjustable feet of the instrument in turn, until the bubble in the spirit level lies entirely within the inner circle. (The instrument can operate with up to 2 ° of tilt, but with reduced performance.)

The feet are mounted on screw threads. To adjust the height of a foot, turn the brass locking nut anticlockwise to loosen it, and rotate the foot so that it screws either in or out. When you are happy with the height, tighten the brass locking nut clockwise to secure the foot.



Note: When locked, the nut should be at the bottom of its travel for optimal noise performance.

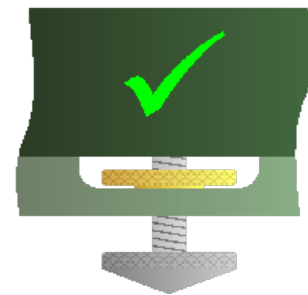
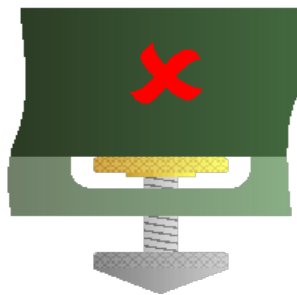

6. Connect a 10 to 28 Volt DC fused power supply to the breakout box.



Caution: Observe the correct polarity when connecting the power supply. The **red** lead must be connected to the **positive terminal**, typically labelled '+', and the **black** lead must be connected to the **negative terminal**, typically labelled '-'. An incorrect connection risks destroying both the instrument and the power supply.

The instrument produces an audible click as it boots up.

7. Connect the GPS receiver to the breakout box.



Note: It can take as long as fifteen minutes for a GPS receiver to produce suitably accurate timing signals, especially if it has been transported any distance.

8. Connect the data cable to a PC. Run Scream!, and check that data are being produced. Optionally, also check the mass position outputs (streams ending M8, M9 and MA). These streams are digitized at a slower rate, and may take up to 15 minutes to appear. Levelling the instrument minimises the values of the mass position outputs: aim for values as close to zero as possible.

9. Using Scream, monitor the status stream of the instrument to ensure that the GPS receiver has obtained a 3D fix and the digitiser is synchronised. This is marked with a line like

```
2016 07 04 07:52:15 Clock sync'd to GPS 2016 07 04
07:53:51 =>> 2016 07 04 07:52:15
```

followed by regular reports like

```
2016 07 04 08:06:00 o/s= -56 drift= -7 pwm= 524544
2016 07 04 08:07:00 o/s= -58 drift= -2 pwm= 524288
2016 07 04 08:08:00 o/s= -68 drift= -10 pwm= 524288
```

These lines show the operation of the clock management algorithm and are only printed to the status stream when the digitiser is correctly synchronised.

10. Cover the instrument with thermal insulation, for example, a five centimetre expanded polystyrene box. This will shield it from thermal fluctuations and convection currents in the vault. It also helps to stratify the air in the seismometer package. Position the thermal insulation carefully so that it does not touch the sensor package.



11. Ensure that the sensor cable is loose and that it exits the seismometer enclosure at the base of the instrument. This will prevent vibrations from being inadvertently transmitted along the cable.

4.5 Installing in pits

For outdoor installations, high-quality results can be obtained by constructing a seismic pit.

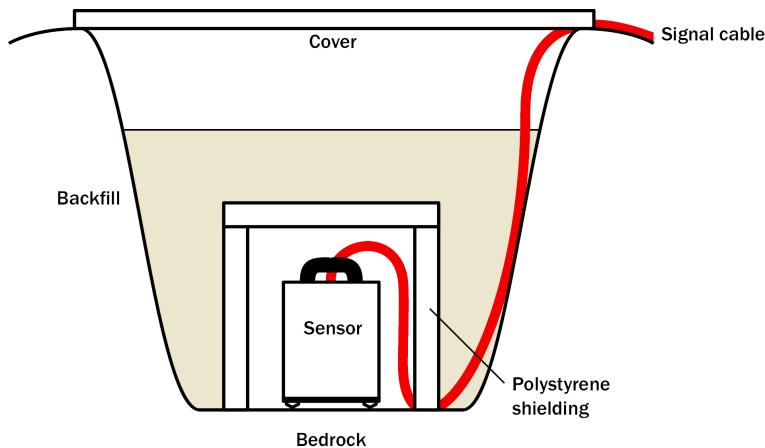

Depending on the time and resources available, this type of installation can suit all kinds of deployment, from rapid temporary installations to medium-term telemetered stations.

Ideally, the sensor should rest directly on the bedrock for maximum coupling to surface movements. However, if bedrock cannot be reached, good results can be obtained by placing the sensor on a granite pier on a bed of dry sand.

1. Prepare a hole of 60 – 90 cm depth to compacted subsoil, or down to the bedrock if possible.
2. *On granite or other hard bedrock*, use an angle grinder to plane off the bedrock at the pit bottom so that it is flat and level. Stand the instrument directly on the bedrock, and go to step 7.
3. *On soft bedrock or subsoil*, you should install a pier as depicted below.

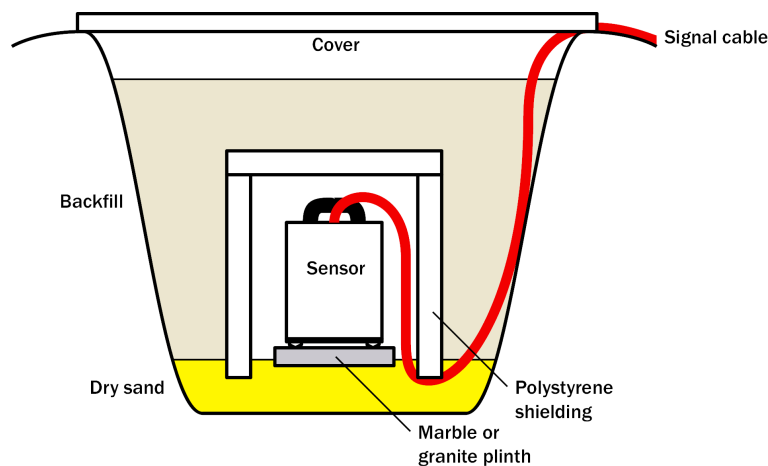

4. Pour a layer of loose, fine sand into the pit to cover the base. The type of sand used for children's sand-pits is ideal, since the grains are clean, dry and within a small size range. On top of the sand, place a smooth, flat granite plinth around 20 cm across, and shift it to compact the sand and provide a near-level surface.



Placing a granite plinth on a sand layer increases the contact between the ground and the plinth, and improves the performance of the instrument. There is also no need to mix concrete or to wait for it to set.

5. *Alternatively*, if time allows and granite is not available, prepare a concrete mix with sand and fine grit, and pour it into the hole. Agitate (“puddle”) it whilst still liquid, to allow it to flow out and form a level surface, then leave to set. Follow on from step 7.

Puddled concrete produces a fine-textured, level floor for emplacing the seismometer. However, once set hard, the concrete does not have the best possible coupling to the subsoil or bedrock, which has some leeway to shift or settle beneath it.

6. *Alternatively*, for the most rapid installation, place loose soil over the bottom of the pit, and compact it with a flat stone. Place the seismometer on top of

this stone. This method emulates that in step 3, but can be performed on-site with no additional equipment.

7. Set up the instrument as described in section 4.4 on page 21 (steps 4 to 9).
8. The instrument must now be shielded from air currents and temperature fluctuations. This is best done by covering it with a thermal shield.

An open-sided box of five centimetre thick expanded polystyrene slabs is recommended. If using a seismic plinth on sand (from steps 3–4 or 5), ensure that the box is firmly placed in the sand, without touching the plinth at any point. In other installations, tape the box down to the surface to exclude draughts.

9. Alternatively, if a box is not available, cover the instrument with fine sand up to the top.

The sand insulates the instrument and protects it from thermal fluctuations, as well as minimizing unwanted vibration.

10. Ensure that the sensor cable is loose and that it exits the seismometer enclosure at the base of the instrument. This will prevent vibrations from being inadvertently transmitted along the cable.
11. Cover the pit with a wooden lid, and back-fill with fresh turf.

4.6 Other installation methods

The recommended installation methods have been extensively tested in a wide range of situations. However, past practice in seismometer installation has varied widely.

Some installations introduce a layer of ceramic tiles between a rock or concrete plinth and the seismometer (left):



However, noise tests show that this method of installation is significantly inferior to the same concrete plinth with the tiles removed (right). Horizontal sensors show shifting due to moisture trapped between the concrete and tiling, whilst the vertical sensors show pings as the tile settles.

Other installations have been attempted with the instrument encased in plaster of Paris, or some other hard-setting compound (left):



Again, this method produces inferior bonding to the instrument, and moisture becomes trapped between the hard surfaces. We recommend the use of fine dry sand (right) contained in a box if necessary, which can also insulate the instrument against convection currents and temperature changes. Sand has the further advantage of being very easy to install, requiring no preparation.

Finally, many pit installations have a large space around the seismometer, covered with a wooden roof. Large air-filled cavities are susceptible to currents which produce lower-frequency vibrations, and sharp edges and corners can give rise to turbulence. We recommend that a wooden box is placed around the sensor to protect it from these currents. Once in the box, the emplacement may be backfilled with fresh turf to insulate it from vibrations at the surface, or simply roofed as before.

By following these guidelines, you will ensure that your seismic installation is ready to produce the highest quality data.



4.7 Rapid installation

The 6TD is specially designed for rapid installation, and may be fully installed in a few hours. This section details a method of deploying 6TD instruments with the minimum of additional equipment. This is recommended for situations where seismic instrumentation needs to be installed very quickly, e.g. to study a resumption of volcanic activity, or where difficulty of access to the site prevents you from constructing a full seismic pit. You should always construct a pit if possible (see section 4.5 on page 24), since the data produced will be of significantly higher quality.

1. Prepare a hole of 60 – 90 cm depth to compacted subsoil, or down to the bedrock if possible.
2. Clean the hole down to the bottom, and remove any loose material from the mouth. Ensure that the bottom of the hole is relatively flat.



3. If the bottom of the hole is made of hard rock, you may need to put in some loose sand or soil so that the sensor can be levelled.
4. Connect the sensor to cables for the GPS unit and power source. If your 6TD has the Wi-Fi option, connect your antenna to the sensor.



Caution: Observe the correct polarity when connecting the power supply. The **red** lead must be connected to the **positive terminal**, typically labelled '+', and the **black** lead must be connected to the **negative terminal**, typically labelled '-'. An incorrect connection risks destroying both the instrument and the power supply.

5. Carefully insert the instrument into the hole, protected by a tough plastic bag to keep water out. Use a bag strong enough to bear the weight of the sensor and breakout box, so that it can be recovered easily.

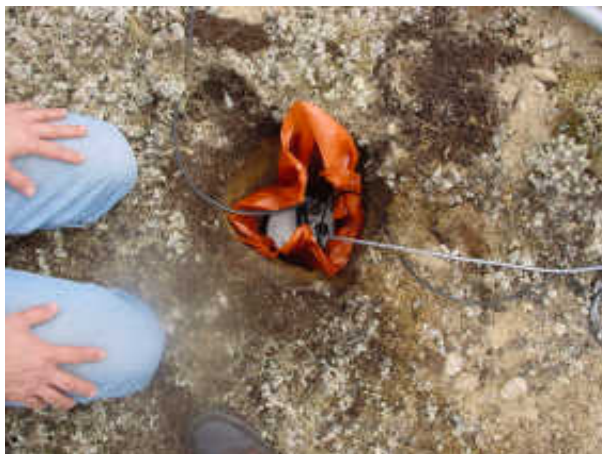

6. Press the sensor down firmly into the soil, without tapping or hitting it.
7. Check the bubble level on top of the instrument package.

Adjust the instrument's position if necessary so that the bubble lies entirely within the black circle.

8. Pack soil or sand around the instrument to hold it steady. Make sure the soil or sand is firmly compacted and not at all loose.
9. Re-check the bubble level. If you cannot adjust the soil packing at this stage and the sensor is not level, you will need to clear the hole and restart from step 3.
10. Place the breakout box and any excess cable on top of the sensor, inside the plastic bag.



11. Group the cables coming from the bag for a distance of about 1 m, and keep them together with insulating tape.
12. Tie the top of the package and fold it over so that water cannot get in. Leave any excess cable within the bag.



13. Cover the installation with soil or sand until it is no longer visible.
14. Attach a GPS unit to the cable coming from the sensor. Position it so that it has a good view of the sky.

If possible, place the GPS near the instrument so that it can be found more easily.

15. If you are installing a 6TD with Wi-Fi, connect and install the antenna.
16. Bury the cables so that they cannot be seen.



17. If you are using a battery as a power source, dig a second hole for it. This hole does not need to be as deep as the pit for the instrument—perhaps 10 cm plus the height of the battery.
18. Attach the sensor power cable to the battery, and wrap it in another plastic bag. Place the bag in the hole.



Caution: Observe the correct polarity when connecting the power supply. The **red** lead must be connected to the **positive terminal**, typically labelled '+', and the **black** lead must be connected to the **negative terminal**, typically labelled '-'. An incorrect connection risks destroying both the instrument and the power supply.

19. Tie the bag and fold over, to make the battery as waterproof as possible.
20. Bury the power cable between the battery and the instrument, and compact soil or sand around the bag.
21. Fill in and cover the hole so that it is not visible.

4.8 Recovery

Care should be taken when recovering the 6TD, since tapping or banging it can cause damage to the sensors inside. The following instructions assume that you have installed the instrument following the steps above.

1. Find the GPS receiver, which will be the only feature visible from the surface, and follow the buried data cable from it to the instrument.
2. Carefully remove earth from the hole until you find the power cable coming from the instrument.
3. Follow the power cable to the battery pit, and carefully dig away the soil to reveal the battery about 10 cm from the surface.
4. Disconnect the power cable from the battery. (With the power off, the sensor is less likely to suffer electrical damage during recovery.)
5. Return to the location of the sensor, and dig down to it. You should be able to remove a spade's head depth of soil without hitting the instrument. Beyond that, using a small hand shovel, follow the wires and carefully remove the remaining soil until you can see the plastic bag. Take special care not to damage the wires, which should be tied together in the vicinity of the bag.
6. Carry on removing soil, either with your hands or (very carefully!) with the shovel, until the whole bag is uncovered to about half the height of the instrument.
7. *If the hole is relatively dry*, open the bag and remove the breakout box and cabling. Lift the instrument out by its handle.



Caution: Do not lift the instrument by any of the attached cables. Straining the cables may result in invisible damage, making future installations unreliable.

8. *Alternatively*, if the hole is waterlogged, carefully lift out the entire bag in one piece, and remove the contents at the surface.

4.9 Networking overview

The 6TD can optionally be supplied with no networking, with a wired Ethernet connection or with both wired and wireless Ethernet connections.

- For wired-only units, the networking capabilities are provided by an embedded Lantronix WiPort-NR module.
- For wireless-equipped units, the networking capabilities are provided by an embedded Lantronix WiPort module.

Additional information about both modules is obtainable from Lantronix's web-site: www.lantronix.com.

The Lantronix modules are both twin-channel serial-to-TCP converters. Channel one's serial interface is exposed on the instrument's main connector; this can be used to provide networking capabilities to any external device with an RS232-compatible output. Channel two is internally connected to the standard digitiser output in such a way that, if a serial device (such as a terminal emulator) is detected on the DATA OUT port, the networking module is disconnected. Hence, networking is only available when the DATA OUT port is disconnected.

 **Note:** Note that the wired and wireless capabilities of the WiPort are also mutually exclusive: only one can be active at a time and, indeed, the wireless interface cannot even be configured when the device is in wired mode.

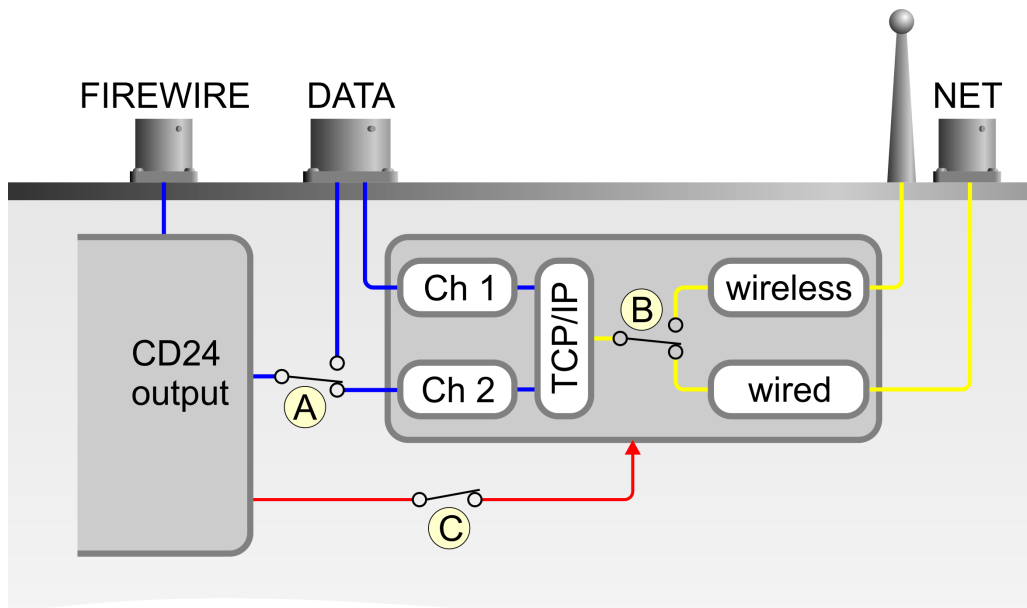

- Ⓐ serial device detection
- Ⓑ software control (Lantronix menu)
- Ⓒ software control (CD24: **ETHER ENABLE/DISABLE**)

The illustration above shows serial data in blue, network data in yellow and power connections in red.

The Lantronix module can be powered down with the CD24 command

ETHER DISABLE

and powered up with the command

ETHER ENABLE

Certain operations, such as a firmware upgrade, can result in power to the Lantronix module being turned off. In these cases, the `ETHER ENABLE` command should be used to restore power.

4.10 Setting up the Ethernet interface

6TD instruments with Ethernet features installed use an embedded Lantronix WiPort-NR module to provide the network interface. This module can be configured using a built-in Web server.

Before you can access the Web server, however, you will need to assign the device an IP address. This can be done using Lantronix' DeviceInstaller utility for Microsoft Windows, or using a DHCP server. You will need a PC with a network interface installed.

4.10.1 Using DeviceInstaller

1. Download and install the DeviceInstaller utility from the Lantronix Web site at <http://www.lantronix.com/>.
2. DeviceInstaller also requires the Microsoft .NET framework to be installed. If you do not have this already, it can be downloaded at <http://www.microsoft.com/>.

Find out the MAC address of the 6TD's network interface. This should be printed on a label on the case.

3. If the Data Out port on the breakout box is connected to anything, disconnect it.
4. Connect the 6TD's **ETHERNET** port to the the PC's network interface, either using a crossover Ethernet cable or through a network hub.

Using a hub, you can connect several 6TDs to the same PC and configure them all at the same time.

5. DeviceInstaller will not work through routers or across the Internet. All the devices need to be on the same network segment as the PC.
6. Run DeviceInstaller.

DeviceInstaller's main window has two panels, a tree on the left (with Lantronix Devices at the top) and a table on the right.

The program will automatically look for Lantronix devices on all of your computer's network interfaces. If necessary, you can narrow the selection by clicking on an entry in the tree on the left.

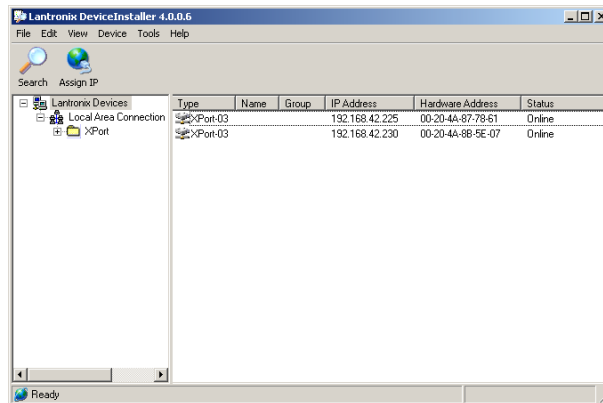

A WiPort-NR entry should appear in the table on the right, denoting that a device has been detected.

If more than one WiPort entry appears, DeviceInstaller has detected several devices.

For every detected device, the program shows the Hardware Address (i.e. the MAC address), and the IP address it is currently using. If your local network uses a DHCP server, the device will ask the DHCP server to assign it an address. Otherwise, a random address will be chosen automatically.

Automatic random addresses all begin with 169.254. The 6TD will choose a different one every time it is power-cycled or rebooted.

- The address of the 6TD may be shown in red with the status **Unreachable**. If this happens, the sensor and PC cannot communicate because they are not on the same subnet.

Click Assign IP () to start the IP configuration wizard.

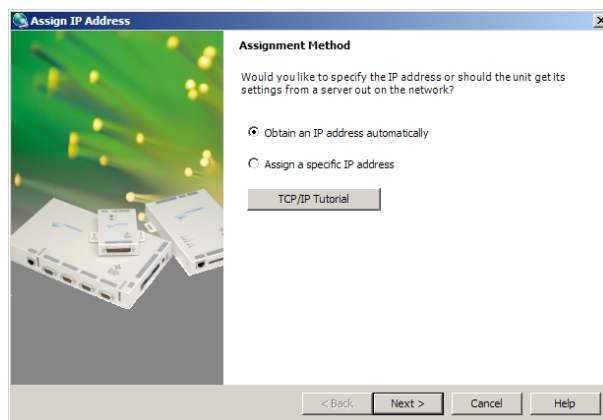

Follow the instructions in the wizard to set the IP address, or configure DHCP if you are using a DHCP server.

Once set, click Search () to find the sensor with its new address.

8. If you want to configure the 6TD to use a static IP address, use the Assign IP wizard as above, and click Search again.
9. Double-click on the entry which corresponds to the 6TD you want to configure.

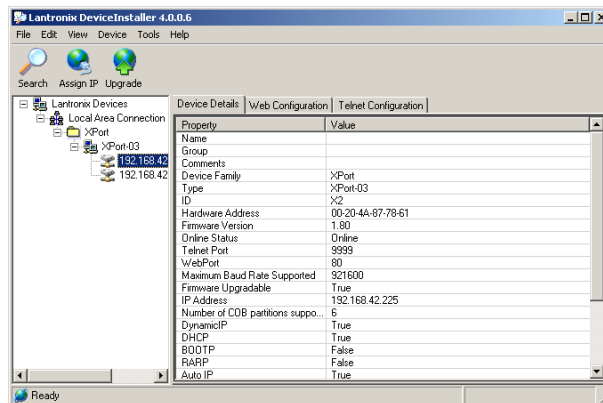

The right-hand panel will change to show the current properties of the device.

10. Switch to the Web Configuration tab, and click Go () to open the Web configuration interface.

Alternatively, click Use External Browser () to use your own Web browser to configure the instrument.

In either case, unless you have previously configured password protection, simply click if prompted for a user name and password.

11. Follow the steps in section 4.10.3 on page 36 to configure the module from its Web interface.

4.10.2 Using DHCP

If you cannot install DeviceInstaller on your PC, or do not wish to, you can also get access to the 6TD using a standard DHCP server. In most cases you will need to have administrative privileges to do this.

1. Install and start the DHCP service on your PC.
2. Connect the 6TD's ETHERNET port to the the PC's network interface, either using a crossover Ethernet cable or through a network hub.

Using a hub, you can connect several 6TDs to the same PC and configure them all at the same time.

DHCP will not work through routers or across the Internet. All the devices need to be on the same network segment as the PC.

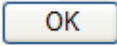
3. Monitor the DHCP server to find out what IP address it gives to each instrument.
4. To configure a device, enter its IP address into a web browser. Unless you have previously configured password protection, simply click  if prompted for a username and password.

4.10.3 Configuration with the Web interface

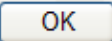
Once you have access to the WiPort-NR's Web interface, you can configure it with its proper settings. Unless you have previously configured password protection, simply click  if prompted for a user name and password.

1. The Web page is divided into three. A menu on the left switches between pages of configuration options on the right. There is also a banner at the top, which tells you the current firmware revision and the MAC address.

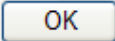
To navigate around the Web site, click on the entries in the left-hand menu. When you have made changes to the settings on any page, save them by clicking  before you leave the page.

2. The WiPort-NR has two serial channels which you can connect to. By default these are exposed on ports 10,001 and 10,002.

Channel 1 (normally port 10,001) is connected to a serial console which is exposed on the instrument's main connector. If you have problems connecting to the 6TD over a network, you can attach a diagnostics cable, CAS-PEP-0041, to this port and use Scream! to access the console.

Channel 2 (port 10,002) is connected to the 6TD's digital output, unless you have connected a serial data cable from the breakout box to a computer. If the breakout box is connected, the 6TD will send data streams through that interface rather than to the WiPort-NR.

Click on Channel 2 – Serial Settings.

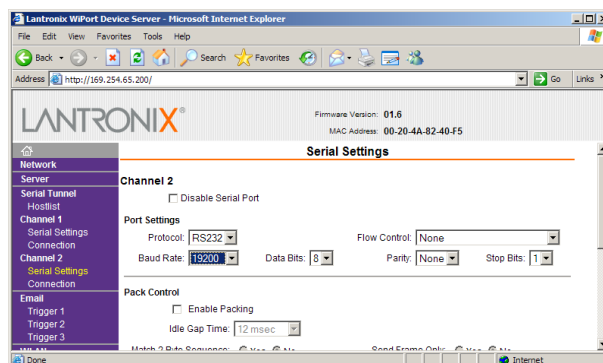

Set the Baud Rate to 19200. This is the default baud rate for the 6TD's digital output.

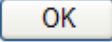

Note: If you change the baud rate in Scream! or using the terminal, you must come back to this page and change the Baud Rate setting.

The remaining settings can be left at their default values. Click  to save your changes.

For full information on the WiPort-NR's configuration options, please refer to the WiPort documentation, which is available on the Lantronix Web site, <http://www.lantronix.com/>.

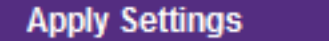
3. When you have finished setting up the WiPort-NR, apply the new settings by clicking . The WiPort-NR will re-boot with the new settings in effect.

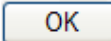
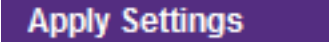

Note: Simply changing settings in the web page and clicking  does not effect any functional change. You must click  before the changes take effect.

If the WiPort-NR is using an automatically chosen random IP (beginning with 169.254), the IP address will change when you do this. You will need to go back to DeviceInstaller to find out the new IP address.

4.11 Setting up wireless networking

6TD instruments with wireless features installed use an embedded Lantronix WiPort module to provide the network interface. This module can be configured using the DeviceInstaller utility for Microsoft Windows, or using a DHCP server. You will need a PC with a wireless card installed.

You may find it easiest to gather together all the Wi-Fi hardware before taking it into the field, and configuring it from a local wireless-enabled PC.

6TD instruments with the wireless networking option also have an ETHERNET port for attaching to a wired network. You can switch between the wired and wireless interfaces using DeviceInstaller.



Note: There are two types of wireless network topology supported by the WiPort, infrastructure and ad-hoc. GSL can only support 6TDs running in infrastructure mode.

4.11.1 Using DeviceInstaller

1. Download and install the DeviceInstaller utility from the Lantronix Web site at <http://www.lantronix.com/>.
2. DeviceInstaller also requires the Microsoft .NET framework to be installed. If you do not have this already, it can be downloaded at <http://www.microsoft.com/>.
3. Find out the MAC address of the 6TD's network interface. This should be printed on a label on the case.
4. Configure your wireless router or access point to use a network name (SSID) of LTRX_IBSS
5. Disable any security features of the wireless router or access point.
6. Run DeviceInstaller. The main window has two panels, a tree on the left (with Lantronix Devices at the top) and a table on the right.

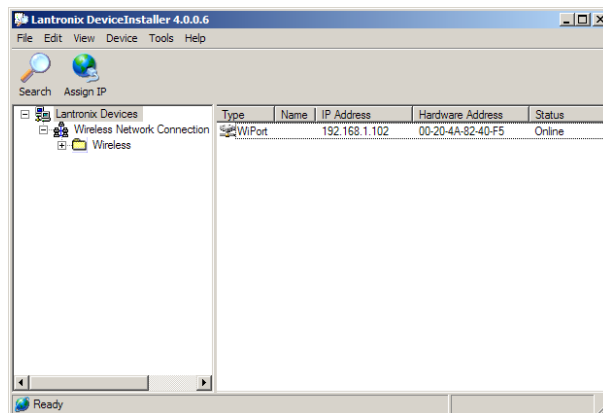

7. The program will automatically look for Lantronix devices on all of your computer's network interfaces. If necessary, you can narrow the selection by clicking on an entry in the tree on the left.

A WiPort entry should appear in the table on the right, denoting that a device has been detected.

If more than one WiPort entry appears, DeviceInstaller has detected several devices.

For every detected device, the program shows the Hardware Address (i.e. the MAC address), and the IP address it is currently using. If you are using a wireless router with a DHCP server, or an access point connected to a network with a DHCP server, the device will use DHCP to assign it an address. Otherwise, a random address will be chosen automatically.

Automatic random addresses all begin with 169.254. The 6TD will choose a different one every time it is power cycled or rebooted.

8. The address of the 6TD may be shown in red with the status Unreachable.

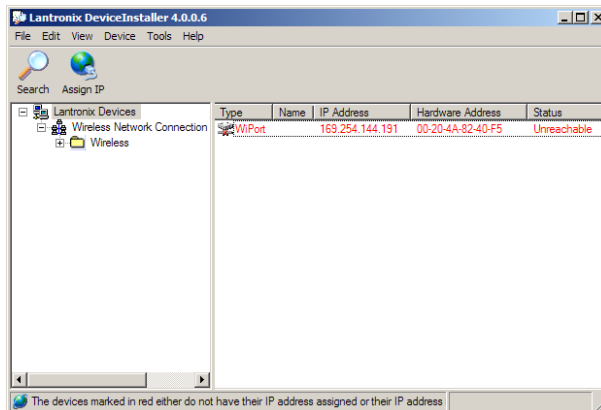

If this happens, the sensor and PC cannot communicate because they are not on the same subnet.

Click Assign IP () to start the IP configuration wizard.

Follow the instructions in the wizard to set the IP address, or configure DHCP if you are using a DHCP server.

Once set, click Search () to find the sensor's new IP address.

9. If you want to configure the 6TD to use a static IP address, use the Assign IP wizard as above, and click Search again.

10. Double-click on the entry which corresponds to the 6TD you want to configure.

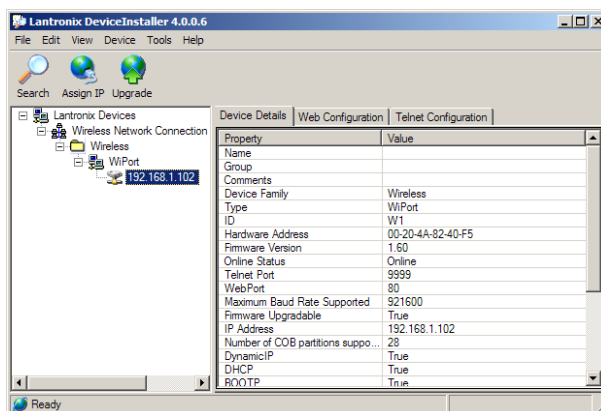

The right-hand panel will change to show the current properties of the device.

11. Switch to the Web Configuration tab, and click Go () to open the Web configuration interface.

Alternatively, click Use External Browser () to use your own Web browser to configure the instrument.

In either case, unless you have previously configured password protection, simply click if prompted for a username and password.

12. Follow the steps in section 4.11.3 on page 40 to configure the module from its Web interface.

4.11.2 Using DHCP

If you cannot install DeviceInstaller on your PC, or do not wish to, you can also get access to the 6TD using a standard DHCP server. In most cases you will need to have administrative privileges to do this.

1. Install and start the DHCP service on your PC.
2. Configure your wireless router or access point to use a network name (SSID) of LTRX_IBSS
3. Disable any security features of the wireless router or access point.
4. Monitor the DHCP server to find out what IP address it gives to each WiPort in range. If necessary, power cycle the sensor(s).
5. To configure a device, enter its IP address into a web browser. Unless you have previously configured password protection, simply click if prompted for a username and password.

4.11.3 Configuration with the Web interface

Once you have access to the WiPort's Web interface, you can configure it with its proper settings. Unless you have previously configured password protection, simply click if prompted for a user name and password.

1. The Web page is divided into three. A menu on the left switches between pages of configuration options on the right. There is also a banner at the top, which tells you the current firmware revision and the MAC address.



To navigate around the Web site, click on the entries in the left-hand menu. When you have made changes to the settings on any page, save them by clicking OK before you leave the page.

2. Click on WLAN (Wireless Local Area Network) to open the WLAN Settings page.

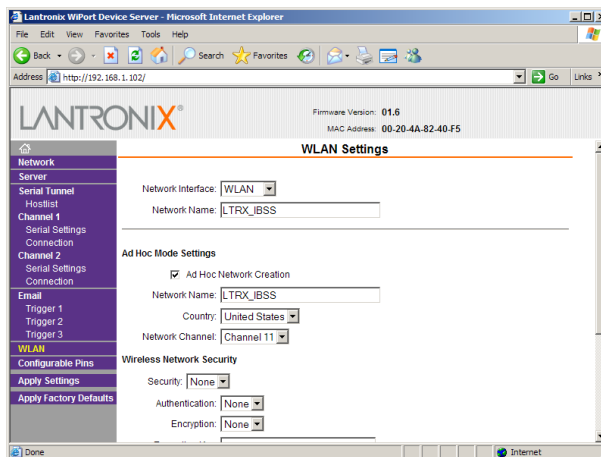

3. Change the Network Name (i.e. SSID) from LTRX_IBSS to a suitable name for your installation. This name will be announced to any nearby wireless devices when they search for networks.

Make a note of the SSID that you have used.

4. Under Wireless Network Security, set Security to WEP and configure the security parameters. If you do not do this, anyone will be able to access the 6TD and change its configuration.

Make a note of the security parameters you have used.

5. Click OK, followed by Apply Settings in the main menu. The WiPort will restart.

If the WiPort is still using an automatically chosen random IP (beginning with 169.254), the IP address will change when you do this. You will need to go back to DeviceInstaller to find out the new IP address.

6. Configure your wireless access point or router to use the new name and security settings, and power cycle the 6TD to make it reconnect to the network.
7. Reconnect your computer to the wireless network using the new name and security settings.
8. The WiPort has two serial channels which you can connect to. By default these are exposed on ports 10,001 and 10,002.

Channel 1 (normally port 10,001) is connected to a serial console which is exposed on the instrument's main connector. If you have problems connecting to the 6TD over a network, you can attach a diagnostics cable, CAS-PEP-0041, to this port and use Scream! to access the console.

Channel 2 (normally port 10,002) is connected to the 6TD's digital output, unless you have connected a serial data cable from the breakout box to a computer. If the breakout box is connected, the 6TD will send data streams through that interface rather than to the WiPort.

Click on **Channel 2 – Serial Settings**.

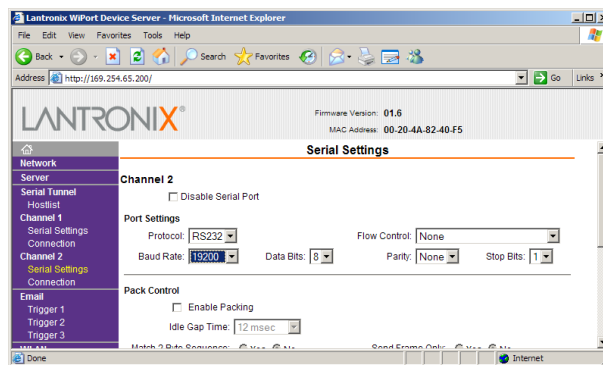

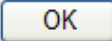
9. Set the Baud Rate to 19200. This is the default baud rate for the 6TD's digital output. If you change the baud rate in Scream! or using the terminal, you must come back to this page and change the Baud Rate setting.
10. The remaining settings can be left at their default values. Click  to save your changes.

For full information on the WiPort's configuration options, please refer to the WiPort documentation, which is available on the Lantronix Web site, <http://www.lantronix.com/>.

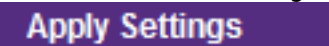
11. When you have finished setting up the WiPort, apply the new settings by clicking . The WiPort will re-boot with the new settings in effect.



Note: Simply changing settings in the web page and clicking does not effect any functional change. You must click before the changes take effect.

4.11.4 Installing wireless hardware

The small antenna supplied with the 6TD is adequate for initial testing or temporary installations with an access point within 50 metres of the instrument.



To send data over a larger distance, or if the line of sight between the antenna and the access point is blocked, you will need to use a larger and more powerful antenna.

You can reduce the power requirements by using a directional antenna pointed at the location of the access point. The access point does not need to be permanently present. For example, you could set up an array of 6TD instruments with antennas pointed towards a prominent natural feature with a direct line of sight to all the instruments, and access them all from this location using a laptop PC.

4.12 Configuring the built-in digitiser

Autonomous 6TD installations will need to be configured before deployment. You can do this either

- using the graphical interface provided by Scream! (see chapter 6 on page 55),
or
- over a terminal connection (see chapter 8 on page 85).

Both methods provide full access to the configuration options of the built-in digitiser.

In particular, 6TD can operate in a number of transmission modes. These modes determine whether the unit stores data in its on-board Flash memory, sends them over the serial link in GCF format, or does some combination of these. See section 6.2.4 on page 68 for more details.

5 Accessing data

The 6TD has six different transmission modes, which control whether the instrument transmits data via the serial port or network interface, stores data into its flash memory or some combination of both. Transmission modes are described in section 6.2.5 on page 70.

If you choose a transmission mode where data are transmitted in real time, you can receive the data using Güralp Systems' free Scream! software or using a Güralp EAM, Güralp NAM or similar data acquisition system.

If you choose a transmission mode where data are stored in Flash memory, you can recover these data at a later date, using either the FireWire interface or a serial link.



Note: The FireWire interface is very much faster than the serial link: the serial link is intended for real-time data transmission. If you wish to retrieve recorded data, the serial link (and the Ethernet link, if fitted) are only really useful for small, ad-hoc transfers.

The Flash memory is used as a ring buffer. Two pointers into the memory keep track of where data were last read (the "Read Pointer") and last written (the "Write pointer"). When either pointer reaches the end of physical memory, it wraps round back to the beginning. The behaviour of the recording system when the write pointer reaches the read pointer (i.e. when the memory becomes full of data, none of which have been downloaded) is governed by the commands `RE-USE/RECYCLE` and `WRITE-ONCE`, as described in section 6.2.6 on page 74.

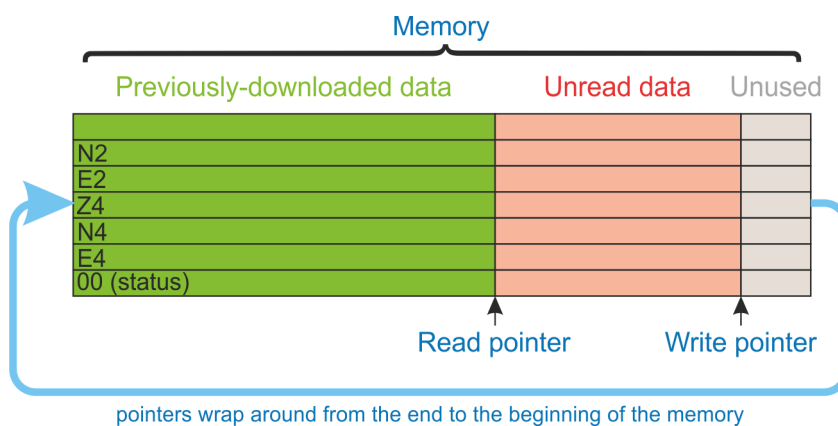

The rest of Chapter 5 describes:

- receiving real-time data in Scream (section 5.1 on page 46);
- downloading data over FireWire to a hard drive (section 5.2 on page 47);
- reading the data from the hard drive onto a PC (section 5.3 on page 48); and
- downloading data over a serial port or Ethernet interface (section 5.4 on page 51).

5.1 Receiving data in Scream!



Note: The Scream! software is available free of charge. Scream is available for both Windows and Linux computers. To request a copy, please send an email to scream@guralp.com stating your name, any organisational affiliation, the equipment with which you are working and the nature of your work.

There are several ways in which a 6TD instrument can connect to Scream!:

- A direct serial connection can be made from the breakout box to your computer. This is the method we recommend for testing the instrument (see section 3.2 on page 12).
- The serial port can also be used to connect an external modem. Details of how to connect modems are available on the Güralp Systems Web site.
- Data can be received from the instrument over the optional Ethernet or wireless links. Before you can do this, you will need to set up its IP address and network configuration, as described in section 4.10 on page 33 (wired) or section 4.11 on page 37 (wireless).

To connect to a 6TD over the network:

1. Run Scream!, and select **Windows** → **Network Control** from the main menu. Click on the **My Client** tab.

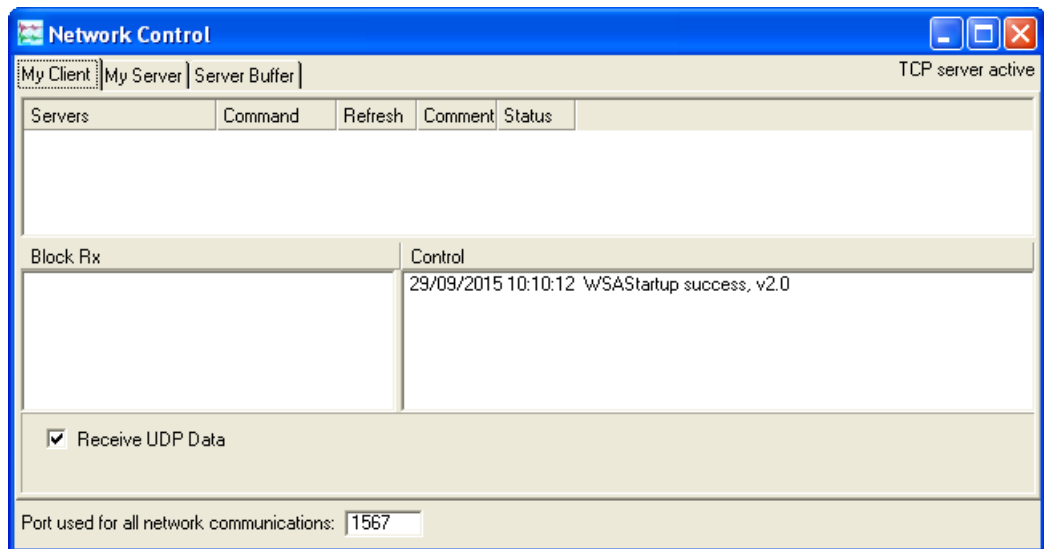

2. Ensure that the check-box marked "Receive UDP Data" is ticked.
3. Right-click in the white panel beneath Server, and select **Add TCP Server...**

4. Type the IP address of the 6TD, a colon (":") and the output port that you chose when configuring the network interface. If you accepted the defaults, this will be port 10,002. The entry should look like

92.168.33.2:10002

Click .

5. After a short wait, an entry for the instrument should appear in the pane. Right-click on the entry and select **Connect**.
6. If the connection is successful, you should see blocks appearing in the Block Rx pane, and streams will appear in Scream!'s main window. Close the **Network Control** window.

5.2 Downloading data over FireWire

The easiest way to download data over Firewire is to connect a suitable disk to the FireWire port of the 6TD and power cycle the instrument.



Note: The 6TD requires the disk to be in DFD format. If the disk has not previously been used with a 6TD (or 3ESPCD), it must first be initialised: see section 8.8.13 on page 103 for details. Once initialised the first time, it can then be reinitialised in the same way or, from within Scream, by selecting **File** → **Reset SCSI disk...** from the main menu

If you have ordered a 6TD with the *powered* FireWire option, you can attach the disk directly to the 6TD with no additional connections. Otherwise, you will need to connect the disk to a power source through the supplied adapter.



When the sensor restarts, it will automatically mount the disk and flush all new data to it.

If you do not want to restart the instrument, you can also flush data to disk manually:

1. Open the digitiser's console.

- a) If you are using Güralp Systems' Scream! software, right-click on the digitiser's icon (once it appears) and select Terminal...
 - b) If you are using a Güralp EAM, issue the command
data-terminal
and select the digitiser from the resulting menu.
2. Connect a suitable disk to the FireWire port of the 6TD. Power the disk if necessary.
 3. Issue the command `FLUSH`

This will download all data from the 6TD that it has not already transferred. If you want to transfer the entire contents of Flash memory, use the command `FLUSHALL`. For more details, see section 8.8.12 on page 103.
 4. Close the terminal session. If you are using Scream! or an EAM, the 6TD should start transmitting immediately. Otherwise, you may need to issue the command `GO` to start transferring data.

5.3 Reading 6TD disks

The 6TD uses a special disk format, DFD, for recording data. This format is also used by other Güralp digitisers such as the DM24.

You can read this data into a PC using Scream! or the `gcfextract` utility, which are freely available from the Güralp Systems Web site.



Note: The DFD format is not the same as that used by the Güralp Systems EAM data module, which uses an ext3, ext4 or a FAT32-compatible journalling file system.

Güralp Systems can provide fully-tested disks with FireWire and USB connectors. Alternatively, a third-party FireWire disk may be used (although compatibility is not guaranteed).

To read a disk using `gcfextract`:

1. Attach the disk to your computer. You can use FireWire, USB, or any other interface supported by your computer and the disk.
2. Run `gcfextract` and select the required disk from the drop-down list, then click **Scan**.

Gcfextract will scan the disk and display all the streams it finds in the selection area below. For each stream, the Stream ID and the number of blocks found are shown.

This operation requires roughly 12 Mb of available memory for every Gb of space on the disk. If you have a very large disk, your computer may have to use its hard disk to make enough space. This will slow down scanning considerably.

- By default, all streams containing more than 100 blocks are selected for extraction. You can change which streams to extract by ticking or clearing the check box beside each stream.

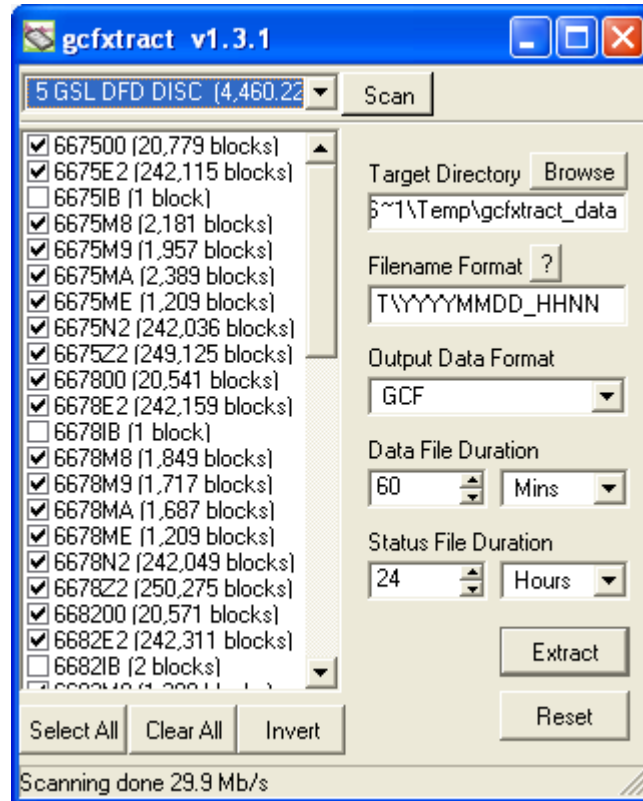



You can tick or clear all of the boxes using the **Select All** and **Clear All** all buttons. Clicking **Invert** ticks all un-ticked boxes, and clears all ticked boxes.

- Enter a path name into the Target Directory field, or use the **Browse** button to find a directory. This will be used as the root directory for extracted data. If it does not exist, gcfxtract will create it.
- Enter a format string into the **Filename Format** field. The syntax is the same as the format string in Scream! and full documentation is available by pressing the **?** button beside the format entry field in interactive mode.
- Normally, gcfxtract outputs GCF files, to ensure all the information in the original data is retained. If you want to convert to a different format, select it from the **Output Data Format** drop-down box. Gcfxtract can output in most of the formats supported by Scream!.

7. Data are automatically placed in time order and saved in multiple files, each file containing a contiguous segment of data. By default, data streams are recorded in files sixty minutes long. To change this to some other number of minutes, alter the value in the **Data File Duration** box. The units (minutes by default) can be selected using the adjacent drop-down menu.

For data streams, if there is a gap in the data, gcfextract will start a new file anyway.

Status streams are also saved in in multiple files, but have a default length of 24 hours. To change this, alter the value under **Status File Duration**. The units (hours by default) can be selected using the adjacent drop-down menu.

8. When you are happy with the settings, click  to begin extracting the data.
9. Clicking  sets a flag on the disk which marks it as empty. The next time a digitiser transfers data, it will begin at the beginning of the disk, overwriting the old data. When this happens, none of the old data can be extracted with gcfextract or Scream!. Until then, however, you will still be able to retrieve all the data.
10. When you are finished, you should exit gcfextract and then use your operating system's standard facility for un-mounting hardware (e.g. "Safely Remove Hardware" under Windows) before disconnecting the drive.

You can also read disks with Scream!. This allows you to view data in the process of being transferred, but is slightly slower, because Scream! does not read data in strict order. To read a disk with Scream!:

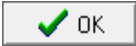
1. Attach the disk to your computer. You can use FireWire, USB, or any other interface supported by your computer and the disk.
2. Run Scream!, and select **File** → **Setup...** from the main menu. Select the Files tab.
3. Set the **Base Directory**, **Filename Format** and **Data Format** as described above. Also, if required, set the **Post-processor** and **Granularity** options to your preference. Consult the Scream! documentation for details.
4. Select the **Recording** tab and tick **Auto Record - Enable for Data Streams** and **Auto Record - Enable for Status Streams**. Click .

Scream! will remember the recording options you set in steps 3 and 4 for later occasions.

5. Select **File** → **Replay SCSI disk...** from the main menu. Scream! will search for attached disks, and open a window with a list of all the streams it has found.
6. Select the streams you want to replay, and click . The disk will appear in the left-hand pane of Scream!'s main window, and the streams you

have selected will start playing into the stream buffer, as well as being recorded.

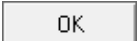
- When you have finished transferring the data, if you want to reset the disk, select **File** → **Reset SCSI disk...** from Scream!'s main menu. Select the disk you want to reset, and click .

5.4 Downloading recorded data over the serial port or Ethernet interface



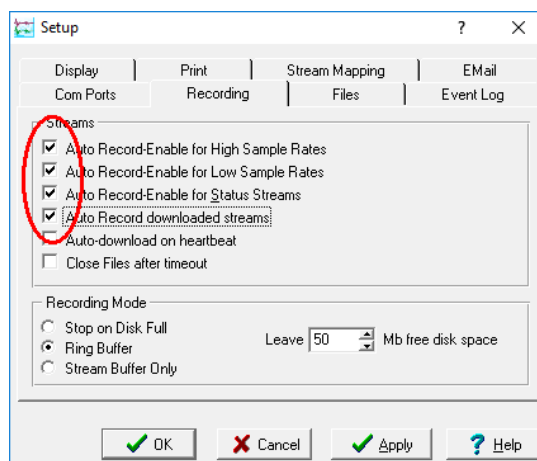

Note: This technique is not recommended for transferring significant quantities of data, due to the speed limitation. The FireWire interface should be used for this purpose: see section 5.2 on page 47.

Start by configuring Scream to record all incoming data by visiting the “Recording” tab of the File→Setup dialogue:



Ensure that the first four check-boxes are ticked. Next, switch to the “Files” tab and choose an appropriate base directory, file format and filename format.

Click  to save your changes and close the dialogue.

Next, open a connection to the digitiser's console. To do this using Güralp Systems' Scream! software, right-click on the digitiser's icon () and select **Terminal...** From a Güralp EAM, issue the command

```
data-terminal
```

and select the appropriate data source from the menu.

To simply download all data held in the Flash memory, issue the command

```
ALL-FLASH ALL-DATA DOWNLOAD
```

followed by

GO

This will initiate a complete download. The **ALL-FLASH** and **ALL-DATA** commands act as modifiers to tell the system what to download.

If you wish to download only a subset of data, you can replace the **ALL-FLASH** and **ALL-DATA** modifiers with other modifiers to select different streams and/or time periods:

- The streams to be downloaded are specified with **ALL-DATA**, **S/S**, or **STATUS-ONLY**.
- Any desired time period can be specified with **ALL-FLASH**, **ALL-TIMES**, or **FROM-TIME** and/or **TO-TIME**.

The parameters are illustrated in the diagram below. If you miss out a parameter, **DOWNLOAD** will re-use the value you last specified.

Time selection → Stream selection

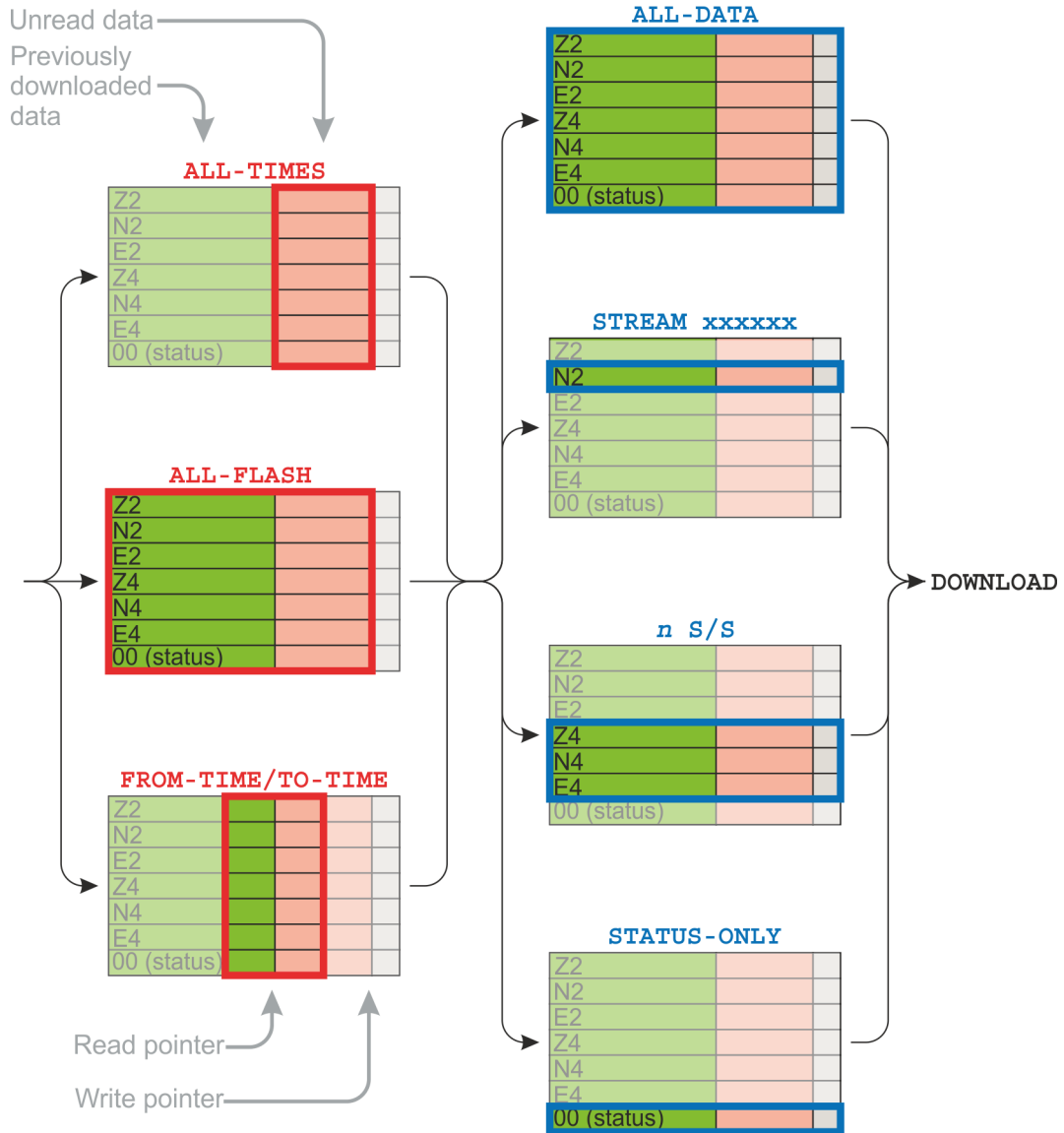

Note: You can pause a download by entering terminal mode, and either restart with another GO or abort with **END-DOWNLOAD**.

When you complete a DOWNLOAD without specifying a time period, the CD24 adjusts the internal read pointer to mark the latest position. This is then used as the start point for the next DOWNLOAD with the command ALL-TIMES.

The various modifiers are summarised below and described in detail in section 8.8 on page 99.

- Time selection
 - **ALL-TIMES** – select all data that have not been previously downloaded

- **ALL-FLASH** – select all recorded data
- **FROM-TIME / TO-TIME** – select data between two user-specified times
- Stream selection
 - **ALL-DATA** – select all recorded streams
 - **STREAM *xxxxxx*** – select only the specified stream *xxxxxx*
 - ***n* S/S** – select only streams with sample rate *n*
 - **STATUS-ONLY** – select only status streams (equivalent to 0 S/S)

The **DOWNLOAD** command returns immediately, so that you can issue more commands if required. To close the connection and begin downloading with the specified selectors, issue the **GO** command.

Once the **GO** command has been issued, the window may close, depending on which emulator you are using. On an EAM, the data-terminal (minicom) session is closed by keying **Ctrl + A**, then **Q**.



6 Configuration with Scream!

The 6TD unit contains a built-in 3-channel digitiser, which can be configured using Güralp System's Scream! software package.

6.1 Configuring the digitiser

Scream! 4 distinguishes between configuration and control of digitisers. The most important difference is that a digitiser may be controlled through Scream! at any time whilst it is acquiring data, whereas configuration options only take effect after a reboot (with consequent loss of data).

To change the configuration of any connected digitiser:

1. Locate the digitiser you want to configure. All connected digitisers have an entry in the tree on the left of Scream!'s main window. If the digitiser is transmitting data through a remote server or EAM, you may need to “unroll” the entry for that server (by clicking on the icon) to see the digitisers connected to it.
2. Right-click on the digitiser's entry (not the icon for the server or any Comxx icon). digitisers are shown with icons depicting a coloured cylinder .
3. Click **Configure...** Scream! will contact the digitiser and retrieve its current configuration, a process which will take a few seconds. When this is done, the Configuration dialogue window will be displayed.
4. Once you are happy with any changes you have made in the Configuration dialogue window, click  to send them to the digitiser and reboot. This will take a short while.

To control a digitiser whilst it is running, either right-click on the digitiser's entry in the list and click **Control...**, or double-click the entry. In either case Scream! will contact the digitiser to retrieve control information and display the Control window. The options you can control immediately are:

- the type of sensor you are using,
- GPS power cycling options,
- the short-term and long-term average values for triggering (but not which streams perform the trigger, or which are output by it) (see section 6.1.3.1 on page 59),
- the length of pre-trigger and post-trigger periods,
- calibration signal options, and
- mass control functions.

Some of these options can also be altered in the Configuration dialogue window. For more information on the Configuration window, see section 6.1 on page 55.

If you need a more powerful interface to the 6TD, you can also issue commands to it directly using Scream!'s terminal mode. A terminal window is opened by right-clicking on the digitiser's entry in the list and selecting **Terminal....** The digitiser will stop transmitting data while you have a terminal window open, but may still store it in Flash memory (depending on the current transmission mode – see section 6.2.4 on page 68).

The remaining sections of this chapter describe in detail the configuration options available for the 6TD. Many of these options are also available for other Güralp digitisers.

6.1.1 System ID

The System ID pane gives information about the digitiser and its internal software, and allows you to change GPS timing parameters.

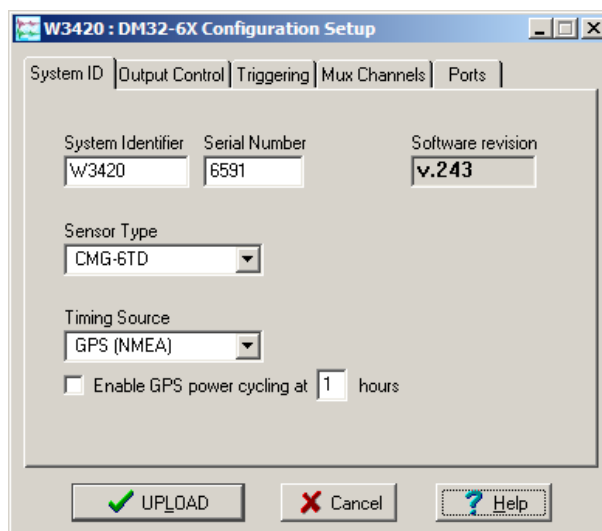

System Identifier and Serial Number : The digitiser type is identified by its system identifier and serial number. Every data and status block generated by the digitiser includes these two fields at the beginning, so that the block's origin can be identified. On delivery from the factory, the system identifier and the serial number are set to the GSL works order number and the digitiser's serial number, but any combination of letters A-Z and numbers can be used, such as an abbreviation of your institution's name, etc. The system identifier can be up to 5 characters long, whilst the serial number cannot be longer than 4 characters.

Sensor Type : This option tells Scream! which control commands to make available to the user. The 6TD does not require separate control commands, so you should not change this option.

GPS Type : The digitiser needs to be able to time-stamp accurately all data that passes through it. It sets its clock by receiving time signals from the GPS satellite

network using an attached Trimble GPS unit. This is hard-wired into the 6TD, so the GPS Type setting has no effect.

Enable GPS power cycling : If you are using a GPS unit to receive time signals, but do not experience significant drift in the system's clock (for example, in an environment with a stable temperature), you can save power by selecting Enable GPS power cycling. With this option in use, the GPS time is only checked at intervals of a specified number of hours. Disabling this option keeps the GPS unit running constantly; if you have ample power, this will give the most accurate results. You can choose any whole number of hours for the interval.

6.1.2 Output control

The Output control tab allows you to configure which data streams are sent to Scream! from the digitiser.

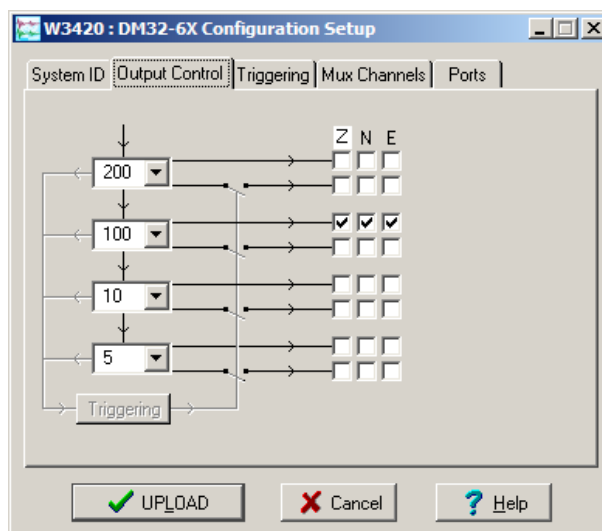

The 6TD initially samples incoming data at 2,000 Hertz. These data are then filtered and reduced to a lower rate (decimated) using an on-board digital signal processing unit, or DSP. The DSP has several filtering/decimation stages, which run one after the other. Stages which can produce output are called taps. The 6TD can output up to four taps simultaneously.

Each configurable tap can be set to a different decimation factor by choosing values from the drop-down menus on the left. Decimation factors of 2, 4, 5, 8, and 10 are available. The numbers visible in the drop-down menu of each tap are the data rates that each of the possible decimation factors could provide, given the settings of the taps above it. Only integer (Hertz) data rates are allowed: thus, for example, if one tap emits data at 25 Hertz, the only possible further decimation factor is 5.

To the right of each decimation factor menu is a grid of check-boxes. These boxes mark which streams of data to generate at each sample rate. The screen-shot above shows a possible configuration for a triaxial instrument. Every channel of the

digitiser may be output at any tap; currently, all three axes are being output at Tap 2 (20 Hertz).

If you want to change the names used for the channels, click in the white box containing a Z in the above picture, and type a letter or number. It will name the channels with a sequence of letters or numbers beginning with the one you choose (e.g. A-B-C, 2-3-4, 9-A-B), unless you type Z in which case they will revert to Z, N, and E.

Each combination of channel and tap has two check-boxes. The upper check-box of each pair activates continuous output, whilst the lower activates triggered output. In the example above, the digitiser will output data continuously for all three channels at Tap 2, but never for any other taps. If you do not need all the streams to output at all rates, you should leave boxes clear to save communications capacity. You cannot select both continuous and triggered output for the same channel and tap.

When you enable a triggered stream, the digitiser will output data in that stream only when a particular set of trigger criteria are met. This is shown diagrammatically as data passing through a switch. In the example above, we might want the high-rate data from Tap 0 to be generated only when an event registers at some other tap. To do this, tick one or more of the lower set of check-boxes for Tap 0.

With this configuration uploaded, Tap 2 will continue to produce output at all times, but Tap 0 will also emit data whenever the trigger criteria are met. The Triggering button is now shown in red to remind you that the trigger is active.

Every ticked check-box in this window will give rise to a data stream coming from the digitiser, which will be displayed in Scream!'s main window when Scream! first receives some data from it. Every stream is identified by a six-character code, where the first four characters identify the digitiser, and the last two characters identify the individual stream. The first four characters are set by default to the serial number of the digitiser; you can change this on the System ID pane (see section 6.1.1 on page 56) or from the digitiser's console.

6.1.3 Triggering

In its standard configuration, the 6TD outputs continuous data at a sample rate you specify. In addition to this, Güralp digitisers can run a triggering algorithm on the data they acquire. This allows you to record data continuously at a relatively low sample rate, but record at a much higher sample rate during short periods when the trigger is active. The parameters controlling the triggering algorithm, and controlling the data output once the system is triggered, are all selectable by the user, permitting maximum flexibility of operation and the most efficient use of available storage space.

The 6TD can be set up for triggered output, that is, to output certain data streams only when a particular trigger criterion is met. The trigger criteria can be tested with data from the same or some other stream. For example, you could use a later tap (with a lower sample rate) as a trigger for output from an earlier, more detailed

tap. Scream! 4 also allows you to configure each digitiser to receive triggers from other digitisers.

To create a new stream with a trigger, open Scream!'s **Configuration** window for the relevant digitiser, and click on the **Output Control** tab. In this pane, a tap which gives rise to a triggered stream has a tick in the lower row of its grid of check-boxes. You cannot configure the trigger criteria until you have selected at least one stream to be affected by the trigger.

Once you have decided which streams should be output when the trigger is activated, you will be able to click on the **Triggering** button to describe the trigger condition. Alternatively, click on the **Triggering** tab at the top of the window. Either action will open the Triggering pane.

There are two triggering algorithms which Güralp digitisers can use: **STA/LTA**, where the ration of the short-term average to the long-term average is monitored, and **level**, where the raw signal level is monitored.

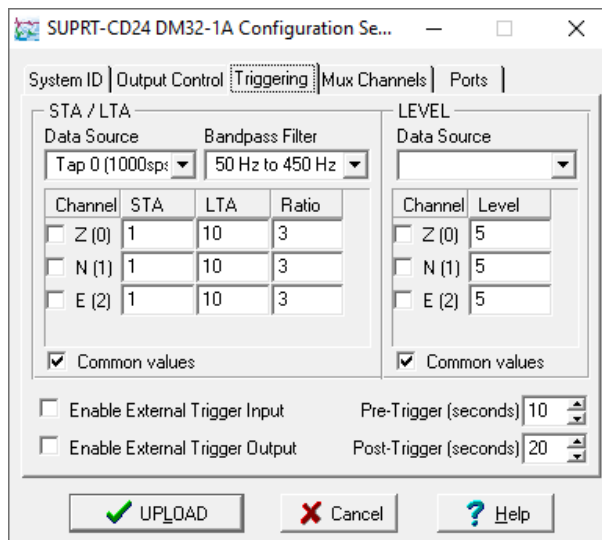

6.1.3.1 STA/LTA triggering

The STA/LTA algorithm applies a simple short-term average – long-term average calculation to the triggering stream. It works by identifying sections of an incoming data stream when the signal amplitude increases. The purpose of taking a short term average, rather than triggering on signal amplitude directly, is to make it less likely that spurious spikes will trigger the device. Averaging also introduces an element of frequency selectivity into the triggering process.

You can select which tap is tested for the trigger from the Data source drop-down menu. The tap does not have to output data to Scream! for you to be able to use it here.

Any or all of the channels available at that tap may be used to determine a trigger. You can select which channels are considered by ticking the boxes in the Channel column of the table. If any of the selected channels passes the trigger condition, the

trigger will activate, and will not de-trigger until all of the selected channels have fallen below their respective ratio values.

The STA and LTA columns allow you to set the intervals over which the two averages are calculated, in seconds. Typically, the time interval for the short term average should be about as long as the signals you want to trigger on, while the long term average should be taken over a much longer interval. Both the STA and LTA values are recalculated continually, even during a trigger.

The Ratio column determines by what factor the STA and LTA must differ for the trigger to be passed. Finding the ratio most suited to your needs is best done by experiment. Too high a value will result in events being missed, while too low a value will result in spurious non-seismic noise triggering the system. Like the averages, their ratio is continuously recalculated for all components.



Note: None of the boxes are allowed to be empty, so you will need to enter the new value before removing the old one. Alternatively, you can use the



and



keys to change the values.

For example, setting the STA to 1 second, the LTA to 10 seconds and the Ratio to 4 would give rise to the following trigger behaviour:

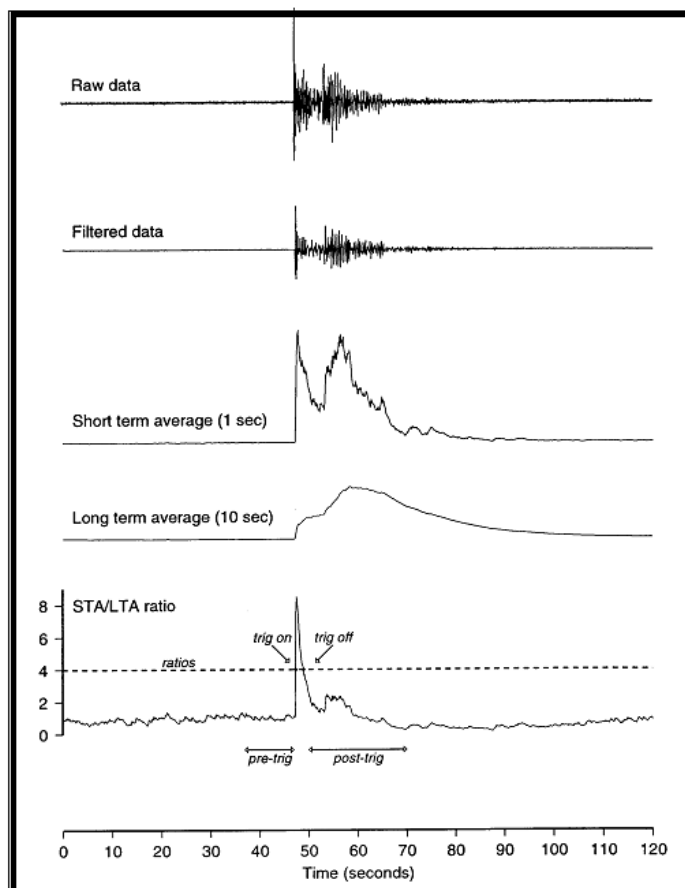

Usually, the values of the **STA** and **LTA** periods, and of the **Ratio**, will be the same for all selected channels. For convenience, Scream! will automatically fill in other values to match ones you enter. If you want to use different values for some channels, you should clear the **Common values** check-box before altering them.

Once you have enabled the STA/LTA triggering method on a particular channel, you can use the **Control** window to change the values of the **STA** and **LTA** periods, together with the **Ratio**, without restarting the digitiser (see section 6.1 on page 55).

Since it is not generally advisable to trigger from broadband data, the digitiser provides a set of standard bandpass filters to apply to the data streams before they are tested for the trigger condition. This filtering serves to maximise sensitivity within the frequency band of interest, and filter out noise outside this band. You can select which bandpass filter to use from the **Bandpass filter** drop-down menu. The corner frequencies of the pass band of the filter are determined by the Nyquist frequency, which is half the sampling frequency of the triggering data. The three filter options have pass bands between 10% and 90%, between 20% and 90% and between 50% and 90% of the data's Nyquist frequency, respectively.

The possible filter configurations are shown in the following table:

Tap #	Rate (samples/s)	Bandwidth 1 (10% → 90%) (Hertz)	Bandwidth 2 (20% → 90%) (Hertz)	Bandwidth 5 (50% → 90%) (Hertz)
0	200	10 – 90	20 – 90	50 – 90
1	100	5 – 45	10 – 45	25 – 45
	50	2.5 – 22.5	5 – 22.5	12.5 – 22.5
	40	2 – 18	4 – 18	10 – 18
	25	1.25 – 11.25	2.5 – 11.25	6.25 – 11.25
	20	1 – 9	2 – 9	5 – 9
2	50	2.5 – 22.5	5 – 22.5	12.5 – 22.5
	25	1.25 – 11.25	2.5 – 11.25	6.25 – 11.25
	20	1 – 9	2 – 9	5 – 9
	10	0.5 – 4.5	1 – 4.5	2.5 – 4.5
	8	0.4 – 3.6	0.8 – 3.6	2 – 3.6
	5	0.25 – 2.25	0.5 – 2.25	1.25 – 2.25
	4	0.2 – 1.8	0.4 – 1.8	1 – 1.8
	2	0.1 – 0.9	0.2 – 0.9	0.5 – 0.9
3	25	1.25 – 11.25	12.5 – 11.25	6.25 – 11.25
	10	0.5 – 4.5	1 – 4.5	2.5 – 4.5
	5	0.25 – 2.25	0.5 – 2.25	1.25 – 2.25

Tap #	Rate (samples/s)	Bandwidth 1 (10% → 90%) (Hertz)	Bandwidth 2 (20% → 90%) (Hertz)	Bandwidth 5 (50% → 90%) (Hertz)
	4	0.2 – 1.8	0.4 – 1.8	1 – 1.8
	2	0.1 – 0.9	0.2 – 0.9	0.5 – 0.9
	1	0.05 – 0.45	0.1 – 0.45	0.25 – 0.45

As can be seen, the sample rates you choose defines the set of permissible filters.

The spectral amplitudes for the various frequency responses available are shown in the figures below.

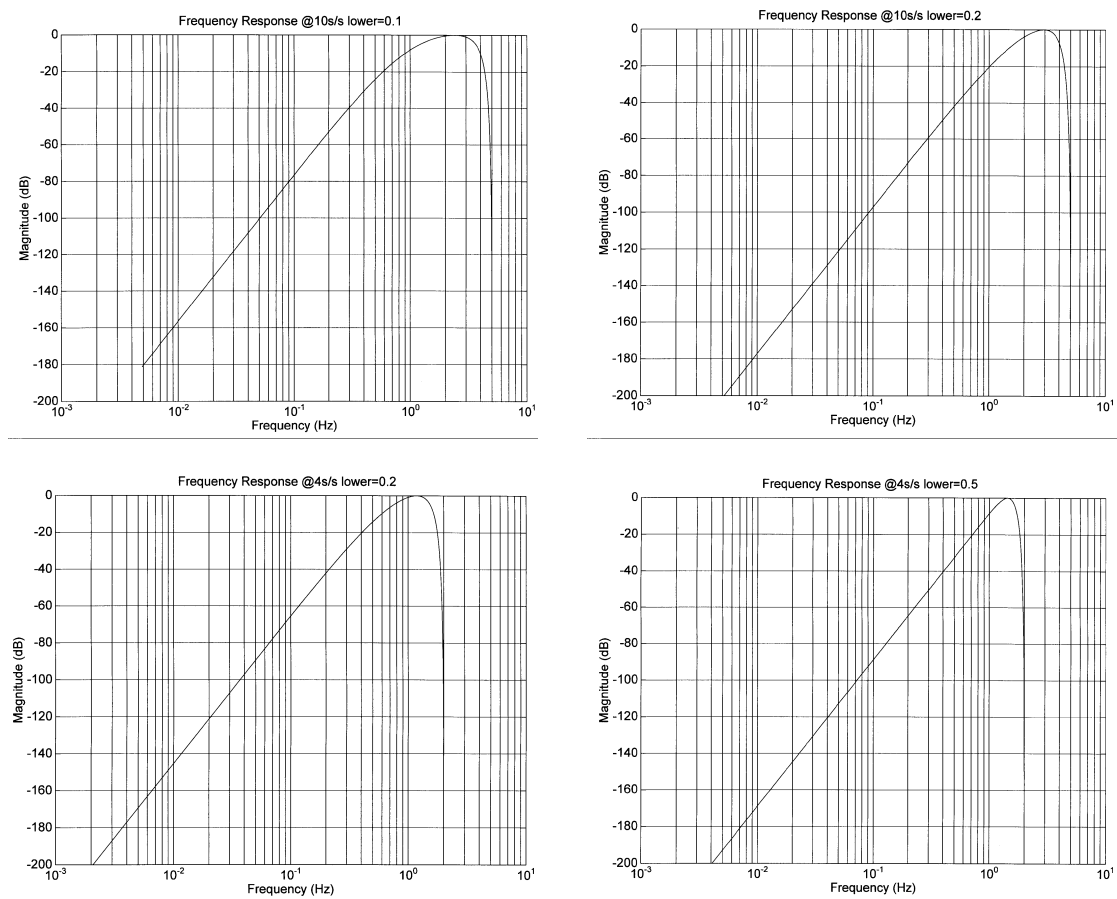

6.1.3.2 Level triggering

Using the Level triggering method, a trigger is generated whenever one of the selected components reaches a certain level above the baseline. You can select which tap is monitored from the Data source drop-down menu, and the channel(s) to be considered from the Channel column of the table. The values in the Level column are the number of counts above the baseline that channel must reach before a trigger is generated.



As with the STA/LTA method, the values of the Level will often be the same for all selected channels. If you want to use different values for some channels, you should clear the **Common values** check-box before altering them.

Once you have enabled the Level triggering method on a particular channel, you can use the **Control** window to change the level at which the system triggers without restarting the digitiser.

6.1.3.3 External triggering

When a digitiser or digital sensor triggers, it sends the trigger itself to connected devices, as well as any extra data that it has been configured to record. You can configure other digitisers to respond to this signal by triggering in turn. This is an option which you can specify at the time of manufacture.

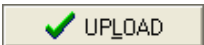
As an example, to instruct a stand-alone digitiser with digital inputs to respond to triggers generated by an attached 6TD:

1. Open the **Configuration** window for the 6TD and tick the **Enable External Trigger Output** check-box to make it send triggers to connected devices.
2. Click  to send the new configuration to the 6TD.
3. Open the **Configuration** window for the digitiser, and tick the **Enable External Trigger Input** check-box to make it listen for triggers coming from the 6TD. Check (in its **Output control** configuration) that it is configured to record data from attached analogue instruments when it receives a trigger.
4. Click  to send the new configuration to the digitiser,

If a 6TD (or digitiser) has both **Enable External Trigger Output** and **Enable External Trigger Input** selected, it will record data when it receives an external trigger as if it had triggered itself but it will not propagate that trigger to other digitisers. It will only send a trigger message if its own triggering criteria are satisfied.

6.1.3.4 Pre-trigger and post-trigger recording

In order to capture all of a seismic event, it is often useful to be able to record data immediately preceding the trigger. Güralp digitisers have an internal buffer of some seconds which allows these data to be added to the triggered stream. Pre-trigger data is particularly useful for emergent-type signals, where the system does not trigger until one phase after the first arrival. In addition, to ensure that the coda of each event is included, some seconds of data are recorded after the system de-triggers.

The two boxes at bottom right of the Triggering pane allow the user to set the pre-trigger and post-trigger data intervals, in seconds. These values determine the minimum length of time during which data will be saved before the trigger condition occurs, and after it has lapsed. Regardless of the intervals chosen, the data in the triggered streams will begin on a whole second.

6.1.4 Mux Channels

The CD24 digitiser, as integrated into the 6TD, provides a range of slow-rate auxiliary channels for reporting the system's state of health and other diagnostic information, known as multiplexed ("Mux") channels. In the 6TD, three channels are used to report the sensor mass position, one measures the internal temperature of the digitiser and one is used for the returning calibration signal (see Chapter 7 on page 77).

The collection and transmission of Mux channels is controlled using the Mux Channels pane:

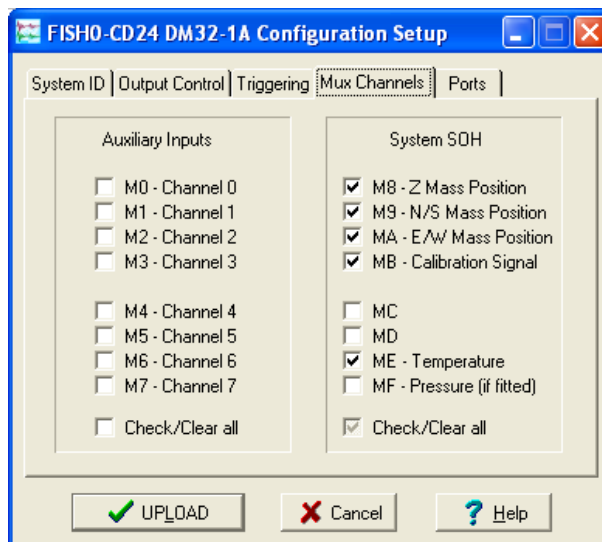

If a tick is placed in the check-box next to a channel, its data will be collected and transmitted as a data stream in GCF format, just as with the normal data channels. To indicate that the data come from a Mux channel, the Stream ID will take the form `****Mx`, where `M` stands for Mux and `x` is a hexadecimal integer (i.e. 0 – 9, and A – F for 10 through 15). The Z, N/S and E/W Mass Position Mux channels appear as `M8`, `M9` and `MA` respectively. `ME` is used for the temperature sensor and `MB` for the returning calibration signal.

6.1.5 Ports

The **Baud Rates** pane of the **Configuration** window allows you to program the baud rate and stop bits for the 6TD's output port.



Caution: If you have a 6TD with Ethernet or Wi-Fi options, the settings you configure here are used both on the standard data output port, and on the internal port which sends data to the Ethernet/Wi-Fi module. If you change them, you will also need to configure the Ethernet/Wi-Fi module to receive data with the new settings. This can be done using the Lantronix DeviceInstaller utility (see section 4.10 on page 33 (wired) or section 4.11 on page 37 (wireless)).

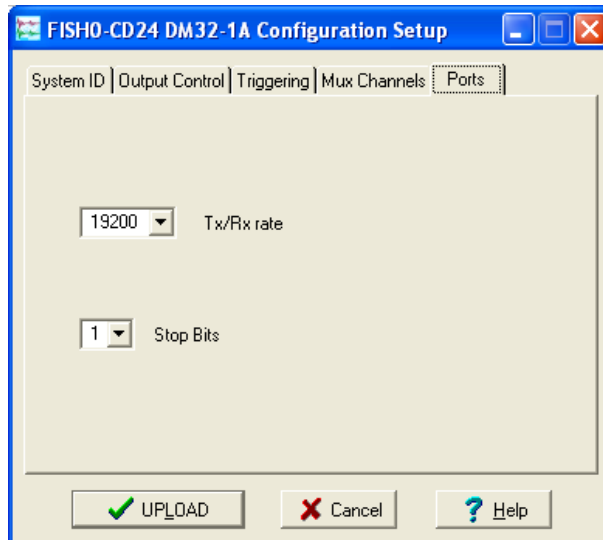

The baud rate you choose must satisfy two conditions:

- It must be high enough to allow all the transmission of all data generated by the digitiser at the sampling rates you have chosen. For three streams of data at 100 Hertz, for example, 9,600 Baud will usually be sufficient. If you wish to transmit 200 Hertz data, however, the baud rate must be at least 19,200.
- It must be low enough to fit within the operating range of the telemetry equipment you are using. While modern modems often offer transfer rates up to 56 kBaud, the telephone or transmission lines may not support these rates. The same holds true for radio telemetry.



Usually, the transmit and receive rates of the data port will be the same. If not, you may select different data rates by removing the tick in the check-box marked **Identical TX/RX rates**.

The **Stop Bits** drop-down menu allows you to choose whether the serial link uses 1 or 2 stop bits. In most cases this can be left at 1, although 2 may be required if you are sending data over 'difficult' transmission lines (for example, some types of radio link). Using 2 stop bits will add a 10% overhead to the data.

You will also need to set the data rate for Scream's local serial port, as well as for the EAM or other communications device (if you are using one). In Scream!, you can configure a serial port by right-clicking on its icon (not that of the digitiser) and selecting **Configure...** from the pop-up menu: for more details, consult the online help

or user guide for Scream!. If you are using an additional communications device, you should consult its documentation to learn how to set its baud rate.

6.2 Controlling the instrument

To control a digitiser whilst it is running, either right-click on the digitiser's entry () in the list to the left of Scream!'s main window (not the Local or Comxx icons) and click **Control...**, or simply double-click the entry. Scream! will then contact the digitiser and retrieve its current status, a process which will take a few seconds, after which the Control window will be displayed. Once you are happy with any changes you have made in the Control window, click  to send them to the digitiser, where they will take effect immediately.

6.2.1 System

When the Control window is first opened, it will be showing the **System** pane.

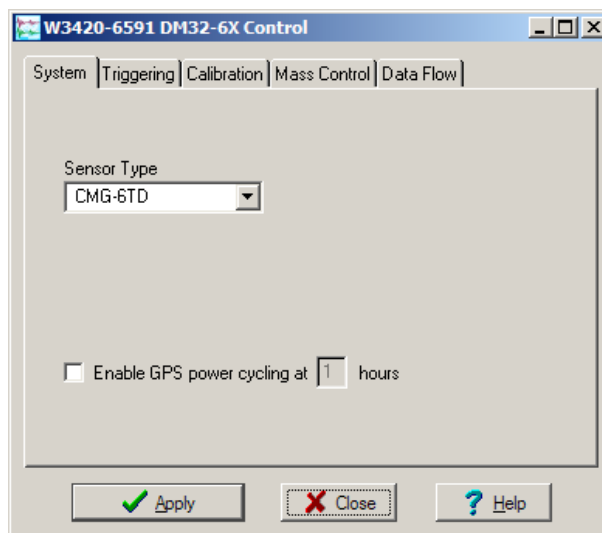

Sensor Type : This option tells Scream! which control commands to make available to the user. The digitiser module is already programmed with the proper sensor type, so you should not change this option.

If you change the Sensor Type, you may have to  the change, close the Control window and open a new one before you can access the Mass Control options.

Enable GPS power cycling : If you are using a GPS unit to receive time signals, but do not experience significant drift in the system's clock (for example, in an environment with a stable temperature), you can save power by selecting Enable GPS power cycling.

When this option is selected, the 6TD will only check the GPS time at intervals of a specified number of hours.

6.2.2 Triggering

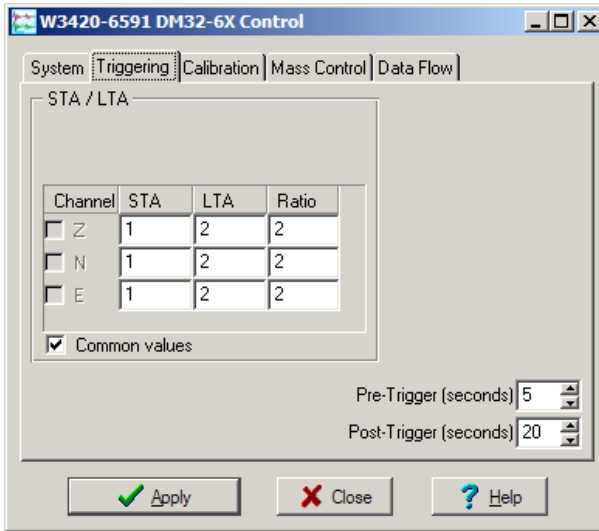

The Triggering pane is very similar to the corresponding pane of the Configuration dialogue, although not all options are available since some require rebooting the digitiser. See section 6.1.3 on page 58 for more information.

6.2.3 Calibration

You can check that your instrumentation is correctly calibrated by injecting known signals into the sensor's feedback loop. The **Calibration** pane allows you to do this.

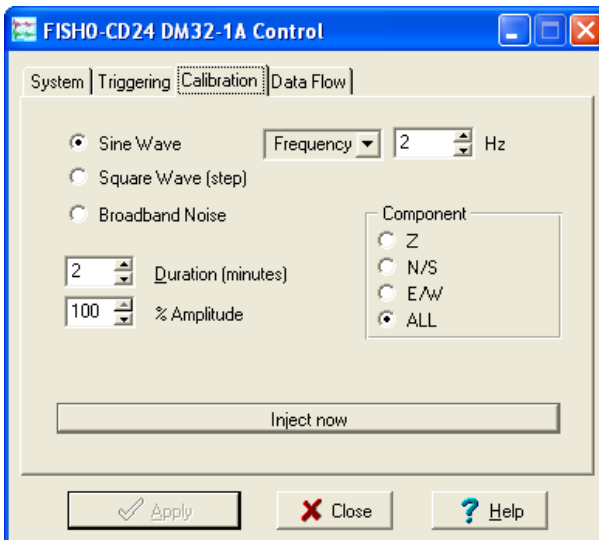

Each channel calibrates the corresponding axis of the instrument. Select one of the Z, N/S and E/W check-boxes to calibrate that axis.

The calibration signal is digitized at a slower rate and returned as a Mux channel (see section 6.1.4 on page 64) with a stream ID ending MB.

The **Duration (minutes)** box tells the digitiser how long to provide the calibration signal before disconnecting. This avoids the system being inadvertently left in calibration mode. The default is two minutes. If you change this setting, it will revert to the default value after one calibration stage.

Three calibration methods are available: Sine Wave, Square Wave (step) and Broadband Noise.

The **Sine Wave** calibration signal always starts and stops on the zero crossing. The frequency or period are specified by the boxes at bottom left. Only integers between 1 and 10 may be specified for either frequency or period, so to generate a 0.5 Hertz signal you should select Period and set the time to 2 (seconds). Likewise, if you require a 0.25 second period you should select Frequency and set the rate to 4 (Hertz). In this manner, you can select frequencies ranging from 0.1 to 10 Hertz (10 to 0.1 second periods).

You can specify step calibration by selecting the **Square Wave (step)** button. The square wave consists of a positive step at the start of the next minute of the digitiser's internal clock, followed by a negative step after a specified number of minutes. After a further delay of the same number of minutes, the calibration signal is disconnected. The default is two minutes. The Period and Frequency are ignored.

The **Broadband Noise** calibration signal consists of a constant stream of pseudo-random noise, which lasts for the specified number of minutes. The Period and Frequency are ignored.

Broadband noise calibration, the most commonly used method, is described in section 7.5.1 on page 80. Other calibration methods, including the interpretation of the results, are fully described in the Scream manual, MAN-SWA-0001.

6.2.4 Data flow

The 6TD operates in one of several transmission modes. These modes relate to how the unit uses its Flash memory:

- as a simple data store, from which you can request data (FILING, DUAL and DUPLICATE modes);
- as a buffer holding unacknowledged blocks, which are transmitted in preference to real-time data (FIFO mode);
- as a buffer holding unacknowledged blocks, which are transmitted whenever the channel is free but no real-time data blocks are ready (ADAPTIVE mode);
or
- not at all (DIRECT mode).

Separate from these modes are the two buffering modes, which tell the unit what to do when its Flash memory becomes full: either:

- carry on, overwriting the oldest data held, or

- stop writing and switch the 6TD into DIRECT mode.

You can switch between transmission and/or buffering modes in Scream! by right-clicking on the digitiser and clicking on **Control...**, then navigating to the **Data Flow** pane:

Clicking  in this window immediately activates the transmission mode and buffering mode that you have selected—there is no need to reboot.

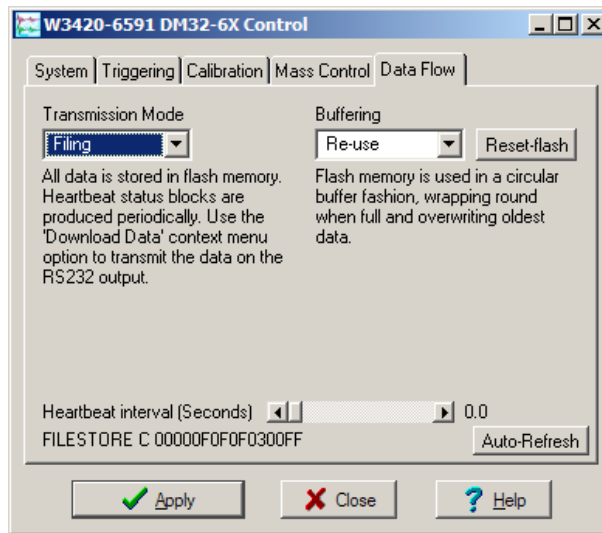

6.2.4.1 Heartbeat messages

When in the FILING transmission mode, an instrument transmits “heartbeat” messages over its data port. These short messages take the place of data blocks, and ensure that programs such as Scream! know that an instrument is present.

You can change the frequency of heartbeat messages from Scream!'s **Control** window, or with the command `HEARTBEAT`.

You can tell Scream! to download new data automatically whenever it receives a heartbeat message from an instrument in FILING mode. This is useful, for example, in autonomous installations connected by intermittent modem links. To enable this feature:

1. Choose **File** → **Setup...** from Scream!'s main menu, and navigate to the **Recording** pane.

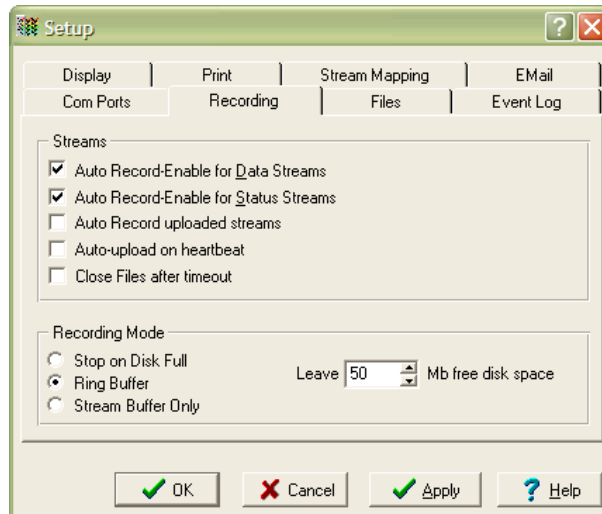

2. Tick the **Auto-upload on heartbeat** check-box.
3. Click .

Using FILING mode with Auto-upload on heartbeat ensures that Scream! receives all new data whenever it can, regardless of the configuration of any devices between you and the instrument.

6.2.5 Transmission mode commands

If you prefer, you can use the 6TD terminal to switch between transmission modes. The commands to use, which take effect immediately, are given below.

6.2.5.1 DIRECT

Syntax: DIRECT

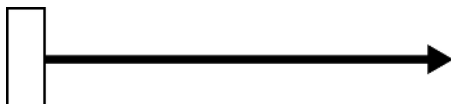

Instructs the 6TD not to use Flash memory for storage. Instead, all data are transmitted directly to clients. An instrument in DIRECT mode still honours the GCF Block Recovery Protocol: a temporary RAM buffer always holds the last 256 blocks generated and, if a client fails to receive a block, it can request its retransmission.

If you expect breaks in communication between the instrument and its client to last more than 256 blocks, or if you want the instrument to handle breaks in transmission (rather than relying on the client to request missed blocks), you should use:

- ADAPTIVE mode, if you want data to stay as near to real time as possible (but do not mind if blocks are received out of order); or
- FIFO mode, if you need blocks to be received in strict order (but do not mind if the instrument takes a while to catch up to real time).

6.2.5.2 FILING

Syntax: FILING

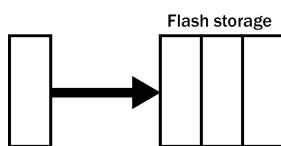

Instructs the 6TD not to transmit blocks to clients automatically, but to store all digitized data in the Flash memory. If you have chosen the RECYCLE buffering mode (see section 6.2.6.1 on page 74), the memory is used in circular fashion, i.e. if it becomes full, incoming blocks begin overwriting the oldest in memory. If the WRITE-ONCE mode is active (see section 6.2.6.2 on page 74), the instrument will switch to DIRECT mode (see above) when the memory becomes full.

You can retrieve blocks from an instrument in FILING mode by connecting to its terminal interface and issuing commands such as FLUSH, or through Scream! (see below).

6.2.5.3 DUPLICATE

Syntax: DUPLICATE

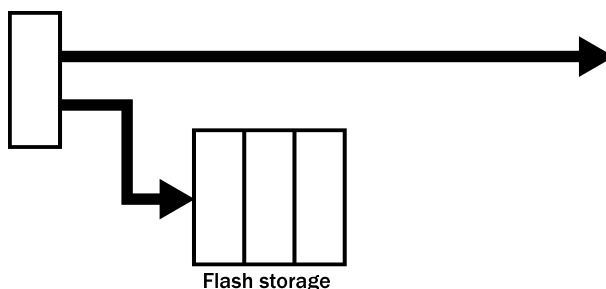

Instructs the 6TD to transmit streams directly to clients as well as storing all data into Flash storage as for FILING mode.

An instrument in DIRECT mode still honours the GCF Block Recovery Protocol: a temporary RAM buffer always holds the last 256 blocks generated, and if a client fails to receive a block it can request its retransmission.

If you expect breaks in communication between the instrument and its client to last more than 256 blocks, or if you want the instrument to handle breaks in transmission (rather than relying on the client to request missed blocks), you should use:

- ADAPTIVE mode, if you want data to stay as near to real time as possible (but do not mind if blocks are received out of order); or
- FIFO mode, if you need blocks to be received in strict order (but do not mind if the instrument takes a while to catch up to real time).

6.2.5.4 FIFO (First In First Out)

Syntax: FIFO

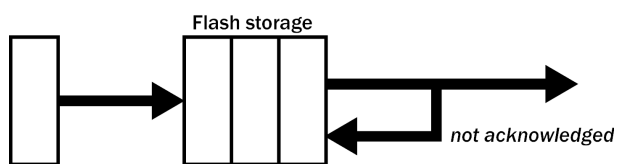

Instructs the 6TD to begin writing blocks to Flash memory as for FILING mode, but also to transmit data to clients. Data are transmitted in strict order, oldest first; the 6TD will only transmit the next block when it receives an explicit acknowledgement of the previous block.

If the communications link is only marginally faster than the data rate, it will take some time to catch up with the real-time data after an outage. If you want data to be transmitted in real-time where possible, but are worried about possible breaks in communication, you should use ADAPTIVE mode instead.

FIFO mode will consider a data block successfully transmitted once it has received an acknowledgement from the next device in the chain. If there are several devices between you and the instrument, you will need to set up the filing mode for each device (if applicable) to ensure that data flow works the way you expect.

Like all the filing modes, FIFO mode does not delete data once it has been transmitted. You can still request anything in the Flash memory using Scream! or over the command line. The only way data can be deleted is if they are overwritten (in the RECYCLE buffering mode, see below) or if you delete them manually.

6.2.5.5 ADAPTIVE

Syntax: ADAPTIVE

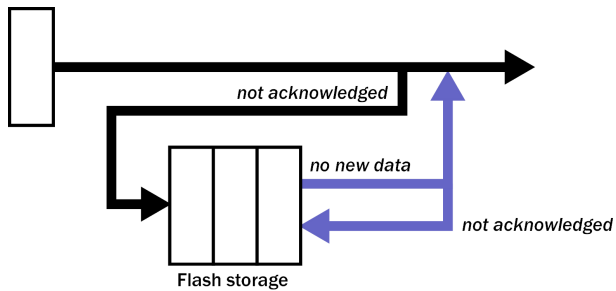

Instructs the 6TD to transmit current blocks to clients if possible, but to store all unacknowledged blocks in the Flash memory and re-send them, oldest first, when time allows. ADAPTIVE mode is best suited for “real-time” installations where the link between digitiser and client is intermittent or difficult of access.

If the communications link is only marginally faster than the data rate, it will usually be busy transmitting real-time data. Thus, it may take a while for the instrument to work through the missed blocks. In this case, and if your client supports it, you may prefer to use the Block Recovery Protocol to request missed blocks where possible.

Some software packages (most commonly Earthworm) cannot handle blocks being received out of time order. If you are using such a package, ADAPTIVE mode will not work, and may crash the software.

6.2.5.6 DUAL

Syntax: DUAL

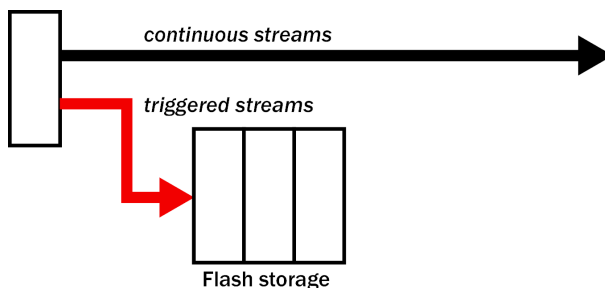

Instructs the 6TD to transmit continuous streams directly to clients as for DUPLICATE mode, but to store triggered data only into Flash storage.

If you choose DUAL mode but do not select any continuous streams for output, the instrument will send heartbeat messages as for FILING mode. Scream! can pick these up and download new data as necessary.

6.2.6 Buffering mode commands

6.2.6.1 RE-USE / RECYCLE

Syntax: RE-USE or

Syntax: RECYCLE

Instructs the 6TD to carry on using the current transmission mode when the Flash memory becomes full, overwriting the oldest data held. This buffering mode is called RECYCLE in Scream! and on the EAM.

For example, in DUAL mode with RECYCLE buffering, the latest continuous data will be transmitted to you as normal, and the latest triggered data may be retrieved from the Flash memory using Scream! or the command line. However, if you do not download data regularly from the Flash memory, you may lose older blocks. This mode prioritises the most recent data recorded by the instrument.

6.2.6.2 WRITE-ONCE

Syntax: WRITE-ONCE

Instructs the 6TD to stop writing data to the Flash memory when it is full, and to switch to DIRECT transmission mode automatically.

For example, in FIFO mode with WRITE-ONCE buffering, the station will transmit data to you continuously, but also save it in the Flash memory until it is full. Once full, the instrument will switch to DIRECT mode and continue transmitting, though no further data will be saved. This mode prioritises the oldest data recorded by the instrument.

6.3 Digitiser status streams

All Güralp digitisers have a separate stream for reporting information about the system, such as their GPS and time synchronization status. This status information is in plain ASCII text format.

To see a Status window for any digitiser, double-click on the Stream ID `xxxx00`. This stream always has a reported sample rate of zero.

During boot-up, each unit reports its model type, firmware revision number, its System ID and serial number. This information is followed by the number of resets that have occurred and the time of the latest reboot from its internal clock. The following lines report the current configuration of the unit's sample rates, output taps, and baud rates. A typical digitiser re-boot status message looks like this:

```

Status - W3420-659100
02/10/2006 14:41:21
2006 10 02 14:40:32 GPS Power On Continuous
Güralp Systems Ltd - DM32-6X \ v.243
W3420 659100 CMG-6
W3420 659100 CMG-6 33rd System re-boot at 2006 10 02 14:41:21
INTERNAL ID FFFFFFFF
FILESTORE C 0000F0F0F0300FF
FILESTORE K 4188128
FILESTORE P 001006CB
02/10/2006 14:41:30
Last Flush : 000000E2 2006 09 18 11:10:25
NO GPS
02/10/2006 14:41:41
N00000001
N00000001
No disk found
2006 10 02 14:41:40 GPS Power On Continuous
02/10/2006 14:43:27
N00000001
N00000001
No disk found
2006 10 02 14:43:26 GPS Power On Continuous

```

The system will produce a similar status message whenever it is powered up, and whenever you reboot it (normally, after changing its configuration).

6.3.1 GPS

If a GPS unit is fitted, its operational status is reported on reboot and the behaviour of the time synchronisation software will also be shown.

From a cold start, GPS will initially report `No GPS time` together with its last position (taken from the internal backup). All messages from the GPS that involve a change of its status are automatically reported. Repeated status messages are not shown to avoid unnecessary clutter.

The report shows the satellites that the system has found, and their corresponding signal strengths.

If the system has not been moved from its previous location, it should be able to find enough satellites to obtain an accurate GPS time fairly quickly; if the GPS receiver has difficulty finding satellites, there may be a delay of several minutes before a new message is displayed.

Before beginning, the digitiser's internal time synchronisation software will wait for the GPS unit to report a good position fix from at least three satellites, for at least six consecutive messages. Messages are normally received every ten to twenty seconds.

The system will then set the internal clock and re-synchronise the analogue-to-digital converters so that the data are accurately time-stamped to the new reference. Any data transmitted up to this point will be stamped with the time from the internal backup clock, which is set to the new accurate time at the end of this process. The re-synchronisation will result in a discontinuity in the data received.

From this point, the control process will attempt to keep the internal time-base synchronised to the GPS 1 pulse per second (PPS) output, by adjusting a voltage-controlled crystal oscillator. First it alters the voltage control to minimise the error. Next, it attempts to minimise both the “phase error” (i.e. the offset between the internal 1 Hertz signal and the GPS) and the drift (the frequency error relative to GPS, which is the first derivative of the phase error). During the control process the system reports the measured errors and the control signal applied, as a PWM (Pulse Width Modulation) value.

During the initial, coarse adjustment stage, only the coarse voltage control is used and no drift calculation is made. If the system is operating in a similar environment to that when the system was last powered (most importantly, the same temperature) the saved control parameters will be appropriate and the system should rapidly switch to the ‘fine’ control mode. The system reports its control status and parameters each minute, with error measurements given in nominal timebase units. In an environment with a stable temperature, the system should soon settle down, showing an offset of only a few thousand (average error $<100 \mu\text{s}$) and a drift rate under 100 counts ($< 1 \text{ in } 10^6$).

7 Calibrating the 6TD

7.1 The calibration pack

All Güralp sensors are fully calibrated before they leave the factory. Both absolute and relative calibration calculations are carried out. The results are given in the calibration pack supplied with each instrument:

- **Works Order** : The Güralp factory order number including the instrument, used internally to file details of the sensor's manufacture.
- **Serial Number** : The serial number of the instrument
- **Date** : The date the instrument was tested at the factory.
- **Tested By** : The name of the testing engineer.

There follows a table showing important calibration information for each component of the instrument, VERTICAL, NORTH/SOUTH, and EAST/WEST. Each row details:

- **Velocity Output (Differential)** : The sensitivity of each component to velocity, in volts per ms^{-1} , averaged across the instrument's pass-band. Because the 6TD uses differential outputs, the signal strength as measured between the +ve and -ve lines will be twice the true sensitivity of the instrument. To remind you of this, the sensitivities are shown as $2 \times$ (single-ended sensitivity) in each case.
- **Mass Position Output** : The sensitivity of the mass position outputs to acceleration, in volts per ms^{-2} . These outputs are single-ended and referenced to signal ground.
- **Feedback Coil Constant** : A constant describing the characteristics of the feedback system. You will need this constant, given in amperes per ms^{-2} , if you want to perform your own calibration calculations (see below).
- **Power Consumption** : The average power consumption of the sensor during testing, given in terms of the current (in amperes) drawn from a 12 Volt supply.
- **Calibration Resistor** : The value of the resistor in the calibration circuit. You will need this value if you want to perform your own calibration calculations (see below).

7.2 Poles and zeroes

Most users of seismometers find it convenient to consider the sensor as a "black box", which produces an output signal V from a measured input x . So long as the relationship between V and x is known, the details of the internal mechanics and

electronics can be disregarded. This relationship, given in terms of the Laplace variable s , takes the form

$$[V / x](s) = G A H(s)$$

In this equation:

- **G** is the acceleration output sensitivity (gain constant) of the instrument. This relates the actual output to the desired input over the flat portion of the frequency response.
- **A** is a constant which is evaluated so that $A H(s)$ is dimensionless and has a value of 1 over the flat portion of the frequency response. In practice, it is possible to design a system transfer function with a very wide-range flat frequency response.

The normalising constant A is calculated at a normalising frequency value $f_m = 1$ Hz, with $s = j f_m$, (where $j = \sqrt{-1}$).

- **H(s)** is the transfer function of the sensor, which can be expressed in factored form:

$$H(s) = N \frac{\prod_{i=1,n} s - Z_i}{\prod_{j=1,m} s - P_j}$$

In this equation, Z_n are the roots of the numerator polynomial, giving the zeros of the transfer function, and P_m are the roots of the denominator polynomial giving the poles of the transfer function.

In the calibration pack, G is the sensitivity given for each component on the first page, whilst the roots Z_n and P_m , together with the normalising factor A , are given in the Poles and Zeros table. Transfer functions for the vertical and horizontal sensors may be provided separately.

7.3 Frequency response curves

The frequency response of each component of the 6TD is described in the normalised amplitude and phase plots provided. The response is measured at low and high frequencies in two separate experiments. Each plot marks the low-frequency and high-frequency cut-off values (also known as -3 dB or half-power points).

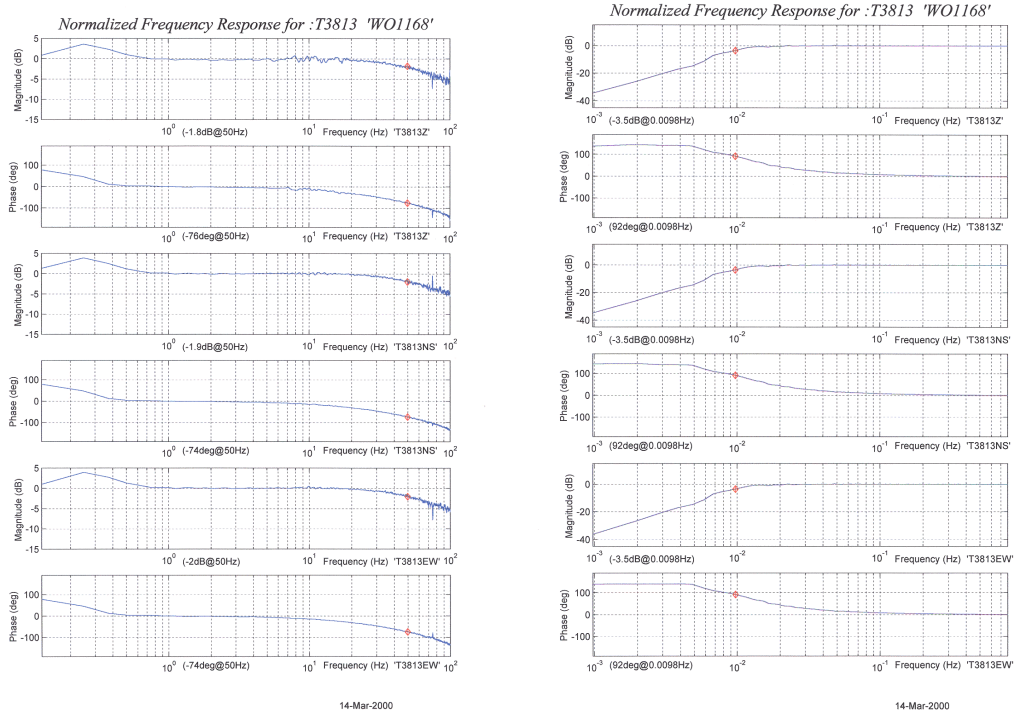

If you want to repeat the calibration to obtain more precise values at a frequency of interest, or to check that a sensor is still functioning correctly, you can inject calibration signals into the system using a Güralp digitiser or your own signal generator, and record the instrument's response.

7.4 Obtaining copies of the calibration pack

Our servers keep copies of all calibration data that we send out. In the event that the calibration information becomes separated from the instrument, you can obtain all the information using our free e-mail service.

Simply e-mail caldoc@guralp.com with the serial number of the instrument in the subject line, e.g.

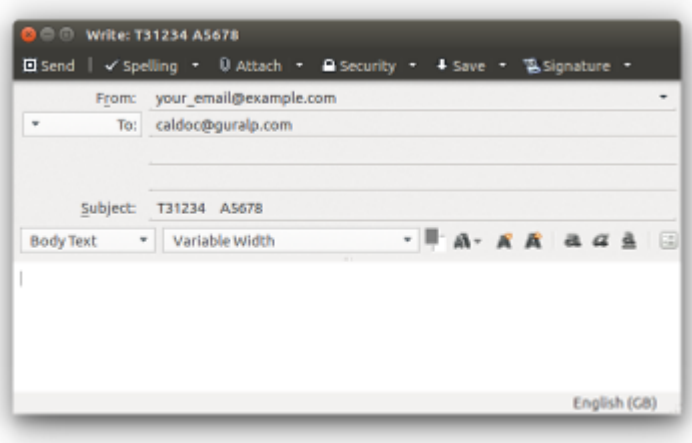

The server will reply with the calibration documentation in Word format. The body of your e-mail will be ignored.

7.5 Calibration methods

Velocity sensors such as the 6TD are not sensitive to constant DC levels, either as a result of their design or because of an interposed high-pass filter. Instead, three common calibration techniques are used.

- Injecting a step current allows the system response to be determined in the time domain. The amplitude and phase response can then be calculated using a Fourier transform. Because the input signal has predominantly low-frequency components, this method generally gives poor results. However, it is simple enough to be performed daily.
- Injecting a sinusoidal current of known amplitude and frequency allows the system response to be determined at a spot frequency. However, before the calibration measurement can be made the system must be allowed to reach a steady state; for low frequencies, this may take a long time. In addition, several measurements must be made to determine the response over the full frequency spectrum.
- Injecting white noise into the calibration coil gives the response of the whole system, which can be measured using a spectrum analyser.







You can calibrate a 6TD sensor using any of these methods, using its built-in signal generator.

7.5.1 Noise calibration with Scream!

The most convenient way to calibrate a 6TD instrument is to use its pseudo-random broadband noise generator with Scream!'s noise calibration extension. The

extension is part of the standard distribution of Scream!, and contains all the algorithms needed to determine the complete sensor response in a single experiment.

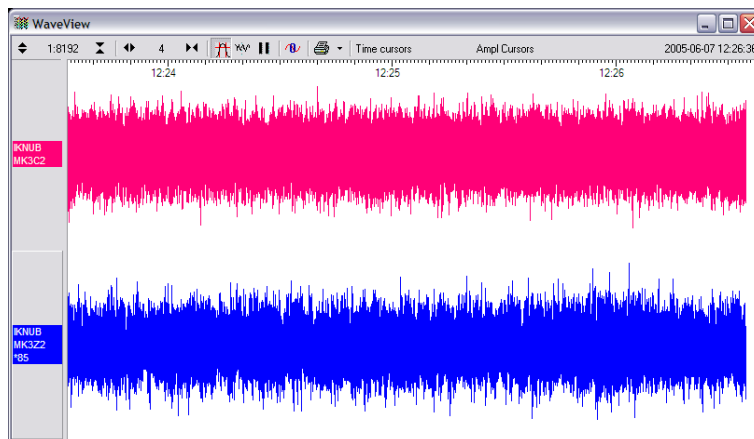

Information on other calibration methods is available on the Güralp Systems Web site.

1. In Scream!'s main window, right-click on the digitiser's icon  and select **Control...** Open the **Calibration** pane.
2. Select the calibration channel corresponding to the instrument, and choose **Broadband Noise**. Select the component you wish to calibrate, together with a suitable duration and amplitude, and click . A new data stream, with a stream ID ending C_n (where n is 0, 2, 4 or 6, depending on the selected tap), should appear in Scream!'s main window. This stream contains the returned calibration signal.
3. Open a WaveView window on the calibration signal and the returned streams by holding  while selecting each of them and then double-clicking. The streams should display the calibration signal combined with the sensors' own measurements. If you cannot see the calibration signal, zoom into the WaveView using the scaling icons at the top left of the window () or the cursor keys  and .



If necessary, drag the calibration stream C_n up the WaveView window, so that it is at the top.

4. If the returning signal is saturated, retry using a calibration signal with lower amplitude, until the entire curve is visible in the WaveView window.
5. If you need to scale one, but not another, of the traces, right-click on the trace and select **Scale...** You can then type in a suitable scale factor for that trace.
6. Pause the WaveView window by clicking on the  icon.

7. Hold down  and drag across the window to select the calibration signal and the returning component(s). Release the mouse button, keeping  held down. A menu will pop up. Choose **Broadband Noise Calibration**.

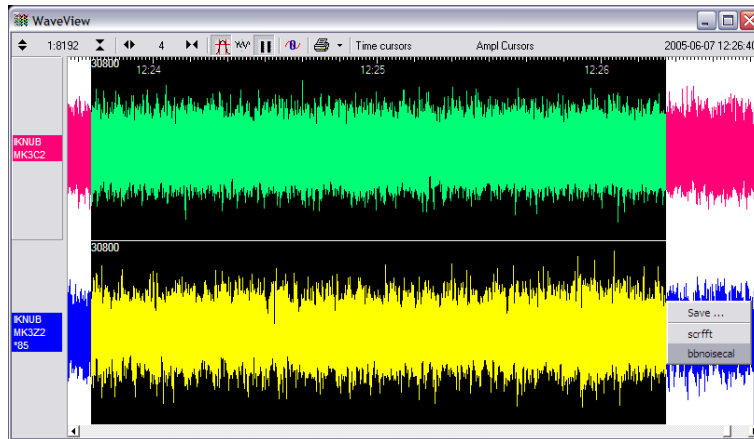

8. The script will ask you to fill in sensor calibration parameters for each component you have selected.

Most data can be found on the calibration sheet for your sensor. Under **Instrument response**, you should fill in the sensor response code for your sensor, according to the table in section 7.5.2 on page 83. **Instrument Type** should be set to the model number of the sensor: this is a free-form text input field and anything you enter here is printed on the resulting graph.

If the file `calvals.txt` exists in the same directory as Scream!'s executable (`scream.exe`), Scream! will look there for suitable calibration values. See the Scream! manual (MAN-SWA-0001) for full details of this file. Alternatively, you can edit the sample `calvals.txt` file supplied with Scream!.

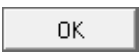
9. Click . The script will return with a graph showing the 6TD's response as amplitude and phase plots for each component.

The accuracy of the results depends on the amount of data you have selected and its sample rate. To obtain good-quality results at low frequency, it will save computation time to use data collected at a lower sample rate; although the same information is present in higher-rate streams, they also include a large amount of high-frequency data which is not relevant in this context.

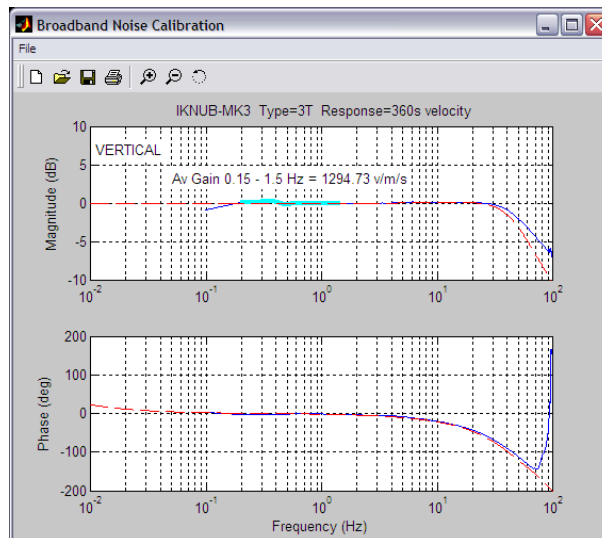

The calibration script automatically performs appropriate averaging to reduce the effects of aliasing and cultural noise.

7.5.2 Sensor response codes

The correct response code for use with your instrument is shown in the table below. If the response of your instrument is not listed, please contact support@guralp.com for advice.

Sensor	Sensor type code	Units (V/A)
CMG-40T-1 or 6T-1, 1 second – 50 Hertz response	CMG-40_1HZ_50HZ	V
CMG-40T-1 or 6T-1, 1 second – 100 Hertz response	CMG-40_1S_100HZ	V
CMG-40T or 6T, 2 second – 100 Hertz response	CMG-40_2S_100HZ	V
CMG-40T or 6T, 10 second – 100 Hertz response	CMG-40_10S_100HZ	V
CMG-40T or 6T, 20 second – 50 Hertz response	CMG-40_20S_50HZ	V
CMG-40T or 6T, 30 second – 50 Hertz response	CMG-40_30S_50HZ	V

7.6 The coil constant

The feedback coil constant K is measured at the time of manufacture, and printed on the calibration sheet. Using this value will give good results at the time of installation. However, it may change over time.

The coil constant can be determined by tilting the instrument and measuring its response to gravity. To do this, you will need apparatus for measuring tilt angles accurately.

1. Measure or look up the acceleration due to gravity, g , at your location.
2. Tilt the instrument slightly, and measure its attitude and the value of the mass position output for the component you wish to calibrate.

To make it easier to measure mass positions, you should use the RESP command to place the instrument into one-second response mode. To do this, open a Terminal window in Scream! (see section 8 on page 85) and issue the commands:

```
OK-1
1 RESP
MASSES?
0 RESP
```

3. Repeat this measurement for several tilt angles.
4. For the horizontal sensor, the input acceleration is given by $a = g \sin \phi$, whilst for the vertical sensor, it is $a = g (1 - \cos \phi)$. The "1" in the equation for the vertical acceleration accounts for the effect of the internal gravity-compensation spring.

Calculate the input acceleration for each of the tilt angles used, and plot a graph of mass position output against input acceleration.

5. The gradient of the line obtained gives the sensitivity of the coil (in V/ms^{-2} , if g was measured in m/s^2 and the mass position in V).
6. The coil constant K is equal to this sensitivity divided by the value of the displacement feedback resistor (which is given on the calibration sheet).

8 Command-line interface

You can connect to the internal software of the 6TD over its output serial port and communicate with it.

To enter command mode from Scream!, right-click on the digitiser's icon () and select Terminal... from the menu that pops up. A window will open, and once the 6TD and computer are communicating properly you will see the prompt

```
ok
```

If you prefer, you can use a terminal program on your computer (such as minicom on Linux, or PuTTY on Microsoft Windows) to connect to the 6TD.

Whilst you are in terminal mode, data transfer will be interrupted; the 6TD may use its Flash memory as a temporary store, depending on how you have configured it. Some commands, such as `SET-TAPS`, require a reboot to take effect.

Güralp EAM and AM modules also allow you to send commands direct to the 6TD using the **FORTH terminal emulator** in the web interface or the command-line tool `data-terminal`. For more information, please see the Platinum manual, MAN-EAM-0003.

If you have problems connecting to the digitiser's console, you should check that the serial port's options and Baud rate are set correctly in Scream! or your terminal program. As supplied, the 6TD expects connections at 19200 Baud, with eight data bits, no parity bit and one stop bit. No flow control (neither hardware nor software) is used.

8.1 FORTH

The 6TD uses a FORTH-like interpreter to implement its features. To issue a command in FORTH, you must supply the arguments before the command, for example:

```
0 19200 BAUD
```

In FORTH, anything you enter is termed a word. New words (case insensitive) are placed on a stack. Some words are known to the system, and may represent commands; if a command finds itself at the top of the stack (e.g. because it is the last thing you typed), they will execute, remove themselves from the stack, and then remove further items from the stack to use as arguments.

Thus, in the command above, the numbers have no immediate effect, so stay on the stack. `BAUD` removes itself and the previous two items (here `0` and `19200`) off the stack, then performs its action using these as arguments.

If a command completes with nothing remaining on the stack, the digitiser will show the prompt `ok`. Otherwise, no prompt will be given. Some commands, such as

SAMPLES/SEC, clear the stack automatically after they execute. Keying ENTER twice will always clear the stack.

Some commands are interactive, and will ask you to provide extra information after you execute them.

In the examples of command-line interactions, a fixed-width typeface will be used:

Example of the fixed-width typeface used.

Commands that you are required to type will be shown in bold:

Example of the fixed-width, bold typeface.

Where data that you type may vary depending on your individual configuration, such as parameters to commands, these data are additionally shown in italics:

Example of the fixed-width, bold, italic typeface.

Putting these together into a single example:

System prompt: **user input with variable parameters**

Some of the less-used commands are not normally available over the terminal interface. In order to access these, you need to import them into the current dictionary with the command `ok-1`. You now have access to the full FORTH word list. To return to the normal state of the interpreter, issue the command `[seal]`.

8.2 General configuration

8.2.1 SET-ID

Syntax: **SET-ID** (interactive)

Sets the system identifier and serial number of the 6TD to values you supply.

```
SET-ID  
System Identifier ( W03008 ) MY6TD  
Serial # ? ( 123400 ) 4507
```

The system identifier you supply may contain up to 5 alphanumeric (0 – 9, A – Z) characters. The 6TD will pad any remaining space on the right with zeroes. If you want to use a system identifier less than 5 characters long, insert zeroes on the left to make it up to 5 characters. The digitiser will interpret leading zeroes as blank. (Because of this, you cannot have a system identifier that begins with a zero.)

The serial number you supply must contain 4 alphanumeric (0 – 9, A – Z) characters as shown. As for the system identifier, leading zeroes are interpreted as blank.

8.2.2 BAUD

Syntax: *port baud-rate* **BAUD**

Sets the baud rate for one of the serial ports on the 6TD, in bytes per second. The 6TD has a single port, numbered 0. For example,

```
0 19200 BAUD
```

This will reset a standard 6TD to its default configuration.

The allowable values for Baud-rate are 4800, 7200, 9600, 14400, 19200, 57600 and 115200.



Note: 38400 Baud is not available on the 6TD.



Note: If you have a 6TD with Ethernet or Wi-Fi options, the settings you configure here are used both on the standard data output port, and on the internal port which sends data to the Ethernet/Wi-Fi module. If you change them, you will also need to configure the Ethernet/Wi-Fi module to receive data with the new settings. This can be done using the Lantronix DeviceInstaller utility (see section 4.10 on page 33 and section 4.11 on page 37).

8.2.3 LOAD

Syntax: **LOAD** (interactive)

Starts an Xmodem file transfer for new 6TD firmware. For full instructions, see Chapter 9 on page 105.



Note: This command is in the extended dictionary; to use it, first issue the command `ok-1` and finish with `[seal]`.

8.2.4 LOAD - I

Syntax: **LOAD-I** (interactive)

Starts an Xmodem file transfer for a new Info Block. This block can be up to 1 Kb long, and will automatically be transmitted from the 6TD when it first powers up. You can use the Info Block to store any information you like: for example, about the digitiser, your project, or calibration data for attached sensors.

If Scream finds calibration information in the Info Block, it will use it to calibrate traces in WaveView windows using physical units rather than counts and it will pre-populate calibration dialogue windows. See the Scream manual, MAN-SWA-0001, for more details.

Before uploading an Info Block, you must convert it to Intel Hex format. Freely-downloadable tools exist that can help you with this conversion. An on-line

converter is also available at the Güralp Systems web-site at <http://www.guralp.com/apps/txt2hex.html>.



Note: This command is in the extended dictionary; to use it, first issue the command `ok-1` and finish with `[seal]`.

8.2.5 TEMP?

Syntax: **TEMP?**

Display the current temperature measurement from the internal thermometer.

8.2.6 ETHER

Syntax: **ETHER ENABLE | ETHER DISABLE**

Enables or disables the optional Ethernet and Wi-Fi devices on the 6TD.

When the Ethernet device is enabled, data produced by the 6TD will be sent to the device for transmission across the network, unless you have plugged a serial cable into the Data Out port of the breakout box. In this case, data will be sent over the standard RS232 interface only. This is the default behaviour.

When the Ethernet device is disabled, data will always be sent out over the standard RS232 interface, and the internal Ethernet/Wi-Fi module will not be used.

8.3 GPS and timing systems

8.3.1 GPS-TYPE

Syntax: *type* **GPS-TYPE**

Tells the 6TD which kind of GPS is attached to it.

type can be one of

- 0, if no GPS is available, or
 - 2, for attached GPS equipment using the NMEA protocol.
-

8.3.2 HR-CYCLE

Syntax: *interval* **HR-CYCLE**

Sets the interval between GPS fixes. Under normal operation, the system will power on the GPS system every interval hours and synchronize its internal clock with GPS

timing signals. Once the internal clock is sufficiently close to GPS time, the GPS system will be automatically powered down for another interval hours.

Setting interval to 0 will make the 6TD leave the GPS on continuously. This is recommended if your installation has access to mains power.

To find out the current HR-CYCLE setting, issue the command `HR-CYCLE?`

8.3.3 XGPS

Syntax: `0 XGPS | 1 XGPS`

Manually switches on or off the GPS system, overriding the `HR-CYCLE` command (see above). If you issue `0 XGPS`, the digitiser will switch off the relay; `1 XGPS` will switch it on. Once the GPS system is switched on, the digitiser will automatically check the timing signal and synchronise its internal clock before switching off the GPS and returning to normal operation.

8.3.4 SET-RTC

Syntax: `year month day hour min sec centisecond SET-RTC`

Sets the system's real time clock. This time will be used from power-up until it is corrected by an attached GPS. If you are not using GPS but are synchronizing from some other time source, you will need to re-issue this command regularly to ensure the 6TD does not drift.

8.3.5 SET-CLOCK

Syntax: `SET-CLOCK (interactive)`

Sets the internal clock.

```

SET-CLOCK
Enter Date & Time -
YYYY MM DD HH MM SS
2006 02 01 12 53 25 Clock set to 2006  2  1 12:53:27
ok_SBHY

```

The time should be entered in the form year month day hour minute second, padding each field with zeroes so that they line up with the guide above.

If the 6TD does not recognize the time format you have used, it will output the message `Invalid Time Entry`.

This setting will be overridden when the GPS system next synchronizes the clock.

8.3.6 TIME?

Syntax: **TIME?**

Displays the current time as held in the system's real time clock. If a GPS is attached, this will be synchronized to it. The output is given in the form

```
year month day hour:minute:second ok
```

8.3.7 .FIX

Syntax: **.FIX**

Displays the current GPS timing fix. The GPS must be attached and powered up for this command to be valid; if it is not, you will see an error message. You can power up the GPS manually with the command XGPS.

The 6TD will reply in the form

```
.fix year month day hour:minute:second ==>> fix-mode SV#'s
satellites ( number-of-satellites ) ok
```

where

- `year month day hour:minute:second` is the current time (if synchronised to GPS);
- `fix-mode` is the fix type (either Auto 2-D or Auto 3-D), and
- `satellites` is a list of the satellites currently visible. The 6TD will carry out clock trimming only if an Auto 3-D fix is available, which requires at least 3 satellites to be visible.



Note: This command is in the extended dictionary; to use it, first issue the command `ok-1` and finish with `[seal]`.

If the 6TD is not attached to a GPS, you will see the message

```
NO GPS
No FIX SV#'s none ok
```

8.3.8 .POSITION

Syntax: **.POSITION**

Displays the current reported GPS position, in the form

```
.position Lat latitude Long longitude ok
```

where *latitude* and *longitude* are displayed in degrees, minutes and seconds.



Note: This command is in the extended dictionary; to use it, first issue the command `ok-1` and finish with `[seal]`.

If the 6TD is not attached to a GPS, you will see the message

```
No position info ok
```

8.3.9 LEAPSECOND

Syntax: `yyyy mm dd LEAPSECOND`

Manually notify the digitiser of an upcoming leap second. This command is not normally necessary, since GPS already has support for leap seconds. However, some units do not properly interpret the GPS signals. See `SQPATCH`, below.

The leap second is taken to be at the end of the day `yyyy-mm-dd`.

8.3.10 SQPATCH

Syntax: `SQPATCH ENABLE | SQPATCH DISABLE`

Enables or disables the internal patch for older GPS receivers based on Trimble Lassen SQ units. These units misinterpret the GPS system's advance notification of a leap second, and consequently run one second slow until the leap second occurs.



Note: This command is only relevant when using GPS receivers built in 2005 and not upgraded since.

With `SQPATCH` enabled, the time reported by the digitiser is offset by 1 second to counteract this problem. If you have set `LEAPSECOND`, above, `SQPATCH` will automatically be disabled when the leap second occurs, and the digitiser will then run normally.

GPS receivers with the latest firmware do not suffer from this problem.

To find out whether `SQPATCH` is currently enabled, issue the command `.SQPATCH`

8.4 Output configuration

8.4.1 SAMPLES/SEC

Syntax: `tap-0 tap-1 tap-2 tap-3 SAMPLES/SEC`

The DSP software on the 6TD supports up to seven cascaded filter/decimation stages. Each stage can be set to one of three decimation factors, which divide the sample rate by 2, 4 or 5. Decimation factors of 8 and 10 are also available, which the 6TD

produces by combining two decimation stages. As a result, data can be output at up to four concurrent data rates. These configured output stages are called *taps*.

The ADC within the unit outputs data at 2,000 samples per second, so taps can have sample rates between 1 and 1,000 samples per second.

The arguments *tap-0* to *tap-3* are the sample rates at each tap in turn, starting with the highest. You must ensure that each rate is lower than the previous one by a factor of 2, 4, 5, 8 or 10. Non-integer values are not allowed.

For example:

```
1000 250 125 25 samples/sec
500 100 5 1 samples/sec
200 100 20 4 samples/sec
400 40 20 10 samples/sec
```

As long as you specify the initial taps, you can omit later ones. The command fills in the value of the missing taps, using a decimation factor of 2 where possible. Thus, the following commands are equivalent:

```
400 40 20 10 samples/sec
```

and

```
400 40 samples/sec
```

8.4.2 SET-TAPS

Syntax: *tap-0 tap-1 tap-2 tap-3 SET-TAPS*

Sets which components are output under normal conditions, and at which tap(s).

tap-0 to *tap-3* are integers below 8, whose binary bits represent the Z (1), N (2) and E (4) components respectively. Each one sets which components are output at that tap under normal conditions.

For example, if you issue

```
1 5 7 0 SET-TAPS
```

- tap 1 will output only the Z component (1);
- tap 2 will output the Z and E components (1 + 4 = 5);
- tap 3 will output all three components (1 + 2 + 4 = 7); and
- tap 4 will not output anything; and

To set triggered output streams, you should use the `TRIGGERED` command described below.

8.4.3 COMPRESSION

Syntax: *bits size* COMPRESSION OR NORMAL COMPRESSION

Sets the maximum amount of compression to use. Greater compression means the digitiser outputs data more efficiently, so more can be transmitted over a link with a given bandwidth. However, compressing streams uses processor power and can increase data latency.

The digitiser compresses data without loss, so compression is most effective when the data contain relatively little information. In most cases, when a seismic event occurs, the digitiser will need to decrease the compression level.

bits can be one of 8BIT, 16BIT and 32BIT. 8BIT (the default) is the maximum amount of compression; 32BIT denotes no compression.

size determines the maximum number of data samples in a GCF block. This must be between 20 and 250; the default is 250.

GCF blocks must be a whole number of seconds long. If you set *size* to a very small value, so that *size* samples is less than one second for some streams, the digitiser will output one block every second for those streams, ignoring the value of *size*.

Thus, if you issue 32BIT 20 COMPRESSION, streams with a sample rate of 20 samples/s and higher will output one block per second, whilst lower rate streams will output 20-sample blocks: every 5 seconds for 4 samples/s data, etc.

The special value, NORMAL COMPRESSION, returns the setting to its default value, and is equivalent to 8BIT 250 COMPRESSION.

8.4.4 ETHER

Syntax: ETHER ENABLE | ETHER DISABLE

For units with integrated networking hardware, ETHER DISABLE turns off the power to the embedded Lantronix networking module, which significantly reduces power consumption if the networking support is not required. The command ETHER ENABLE turns the networking module back on.

8.4.5 MS-GAP

Syntax: *interval* MS-GAP

The GCF protocol allows for transmitted data blocks to be acknowledged by the receiver in order to improve the resilience of links. Unacknowledged blocks can be re-transmitted immediately or stored for later transmission. MS-GAP sets the interval the digitizer should wait for an acknowledgement message, before assuming that the block could not be transmitted. If a period of *interval* passes without an

acknowledgement, the digitizer's behaviour then depends on the current transmission mode (see section 6.2.4 on page 68).

The parameter *interval* is specified in milliseconds. The default is 150. If the value is greater than the average time between blocks being generated and an outage occurs in the return communications link, the digitizer will be producing data faster than it can transmit it and gaps will start to be observed. However, systems using slower communications links (e.g. radio links) may be unable to acknowledge blocks in under 150 ms. You should choose a value for *interval* which is suitable for your particular installation.

8.5 Triggering

8.5.1 TRIGGERS

Syntax: *components* TRIGGERS

Selects which component or components can generate a trigger. Only these components will be examined by the triggering algorithm.

components is an integer below 16, whose binary bits represent the Z (1), N (2), E (4) and auxiliary (8) components respectively. Thus, for example,

- 1 TRIGGERS will trigger from the Z component only (1);
- 6 TRIGGERS will trigger from either the N or E components ($2 + 4 = 6$);
- 7 TRIGGERS will trigger from any of the three components ($1 + 2 + 4 = 7$);
- 0 TRIGGERS will disable the triggering system.

8.5.2 TRIGGERED

Syntax: *tap components* TRIGGERED

Selects which component or components will be output when a trigger is generated, and at which tap (sample rate).

tap is the tap number at which to output the triggered stream. You can set which taps output which sample rate using the *SAMPLES/SEC* command, described above.

components is an integer below 16, which determines which components to output in the same fashion as in the TRIGGERS command, above.

(These two commands have similar names; remember that a component TRIGGERS the system, whilst taps and components can be TRIGGERED.)

8.5.3 STA

Syntax: *Z-secs N-secs E-secs STA*

Sets the length of the “short-term” averaging period in the STA/LTA triggering algorithm.

Z-secs, *N-secs*, and *E-secs* are the time periods over which to calculate the average for the Z, N, and E components respectively. If a component is not considered by the triggering algorithm (see TRIGGERS, above), the value you specify here will be ignored.

For example, *1 2 2 STA* will calculate short-term averages for one second of the Z component, and two seconds of the horizontal components.

8.5.4 LTA

Syntax: *Z-secs N-secs E-secs LTA*

Sets the length of the “long-term” averaging period in the STA/LTA triggering algorithm.

Z-secs, *N-secs*, and *E-secs* are the time periods over which to calculate the average for the Z, N, and E components respectively. If a component is not considered by the triggering algorithm (see TRIGGERS, above), the value you specify here will be ignored.

For example, *15 20 20 LTA* will calculate long-term averages for 15 seconds for the Z component, and for 20 seconds for each of the horizontal components.

8.5.5 RATIOS

Syntax: *Z-ratio Z-ratio Z-ratio RATIOS*

Sets the ratio of STA to LTA above which a trigger will be declared in the STA/LTA triggering algorithm.

Z-ratio, *Z-ratio*, and *Z-ratio* are the time period over which to calculate the average for the Z, N, and E components respectively. If a component is not considered by the triggering algorithm (see TRIGGERS, above), the value you specify here will be ignored.

For example, *4 10 10 RATIOS* will cause the 6TD to trigger if the STA/LTA ratio is above 4 for the Z component, or above 10 for the horizontal components.

8.5.6 BANDPASS

Syntax: *tap filter BANDPASS*

The 6TD passes the stream(s) which generate STA/LTA triggers through a band-pass filter before examining them. The corner frequency of the band-pass filter can be changed with the `BANDPASS` command.

The parameter *filter* takes an integer argument which must be 1, 2 or 5, where:

- *filter* = 1 creates a filter with a corner at 10 % of the Nyquist frequency for tap tap (i.e. 5 % of its sample rate)
 - *filter* = 2 creates a filter with a corner at 20 % of the Nyquist frequency for tap tap (i.e. 15 % of its sample rate)
 - *filter* = 5 creates a filter with a corner at 50 % of the Nyquist frequency for tap tap (i.e. 25 % of its sample rate)
-

8.5.7 PRE-TRIG

Syntax: *time* `PRE-TRIG`

Sets the pre-trigger recording time. *time* is the number of seconds of data to output from before a trigger is declared.

8.5.8 POST-TRIG

Syntax: *time* `POST-TRIG`

Sets the post-trigger recording time. *time* is the number of seconds of data to output after a trigger condition lapses. If an event persists for some time, all triggering components must fall below the threshold before the trigger condition will lapse; only then will the post-trigger period begin.

8.5.9 TRIGGERIN

Syntax: `TRIGGERIN ENABLE` | `TRIGGERIN DISABLE`

Enables or disables external trigger input, in instruments equipped with this option.

Enabling external trigger input allows you to trigger the 6TD from an external logic level supplied through its digital output port. This voltage can be between 5 and 10 V supplied between the Trigger In pin and signal ground. If the 6TD is triggered externally, it will behave exactly as if it had generated the trigger itself.

8.5.10 TRIGGEROUT

Syntax: `TRIGGEROUT ENABLE` | `TRIGGEROUT DISABLE`

Enables or disables external trigger output, in instruments equipped with this option.

Enabling external trigger output allows you to trigger other equipment through a relay contained within the 6TD whenever it triggers. The 6TD's digital output port contains two pins (**Trigger out - common** and **Trigger out - normally-open**) which are connected when it triggers. In particular, you can connect a second digitiser with `TRIGGERIN ENABLE` in effect, in which case triggered data from both instruments will be transmitted whenever the 6TD triggers.

If a 6TD has both `TRIGGERIN ENABLE` and `TRIGGEROUT ENABLE` in effect, only triggers which the 6TD itself has generated will be output. Triggers received through the Trigger in port will cause the 6TD to output triggered streams, but will not be passed on to other digitisers.

8.6 Calibration

8.6.1 SINEWAVE

Syntax: *component freq-or-period unit SINEWAVE*

Instructs the 6TD to inject a sine-wave calibration signal, starting on the zero crossing.

component specifies which component is to be calibrated, one of Z, N/S, or E/W.

freq-or-period and *unit* together determine the frequency of the calibration signal. If *unit* is *HZ*, then *freq-or-period* is taken as a frequency, in Hertz; if *SECOND*, then it is interpreted as a period, in seconds. For example:

```
N/S 4 HZ SINEWAVE
```

The argument *freq-or-period* must be an integer; if you want to specify a period of, for example, 0.5 seconds, you should specify it as *2 HZ* instead.

The calibration signal will be automatically disconnected after two minutes if you have not altered the setting using the `MINUTE` command, described below.

8.6.2 SQUAREWAVE

Syntax: *component SQUAREWAVE*

Instructs the 6TD to inject a square-wave (step function) calibration signal, consisting of a positive step on the start of the next clock minute, followed by a negative step some minutes later (by default, 2). The calibration signal is disconnected the same number of minutes after the negative edge.

component specifies which component is to be calibrated, one of Z, N/S, or E/W.

You can alter the duration of each step using the `MINUTE` command, described below.

8.6.3 RANDOMCAL

Syntax: *component* RANDOMCAL

Instructs the 6TD to inject a white-noise calibration signal generated by an onboard pseudo-random number generator.

component specifies which component is to be calibrated and is specified as one of Z, N/S, or E/W.

The calibration signal will be automatically disconnected after 2 minutes if you have not altered the setting using the MINUTE command, described below.

8.6.4 MINUTE

Syntax: *duration* MINUTE

Sets for how long the next SINEWAVE calibration signal will be injected, or the period of the next SQUAREWAVE calibration signal.

duration is the desired interval, in minutes. If you now issue a SINEWAVE command, the calibration will last *duration* minutes; if the next calibration command is SQUAREWAVE, a positive step of *duration* minutes will be generated, followed by a negative step of a further *duration* minutes.

If you do not issue MINUTE, calibration signals will default to two minutes. This is to avoid the sensor and digitiser inadvertently being left in calibration mode. Issuing, e.g., 5 MINUTE will cause the next calibration signal to last five minutes, but later calibration signals will revert to a duration of two minutes. You will need to issue a MINUTE command before each injection.

Because of the way FORTH works, you can insert MINUTE commands into SINEWAVE or SQUAREWAVE commands, for example:

```
N/S 4 HZ 5 MINUTE SINEWAVE
E/W 10 MINUTE SQUAREWAVE
```

8.6.5 %AMPLITUDE

Syntax: *percentage* %AMPLITUDE

Sets the calibration amplitude to the given *percentage* of the full-scale signal.

8.7 Actions

8.7.1 RESP

Syntax: **value RESP**

The 6TD provides a one-second response mode for use when monitoring mass positions or adjusting offsets. To enter this mode, issue the command **1 RESP**.

Once you have finished monitoring the mass positions, you can return to broadband response mode by issuing **0 RESP**.

8.7.2 MASSES?

Syntax: **MASSES?**

Displays the current, instantaneous position of the three sensor masses, in counts (range $\pm 8,000,000$):

```
masses? z-position n/s-position e/w-position ok
```

8.7.3 RE-BOOT

Syntax: **RE-BOOT**

Causes the 6TD to reset. Some configuration changes will only take effect after you have rebooted the instrument.

8.8 Flash storage and filing



Note: Please see Chapter 5 on page 45 for an overview of data storage and recovery.

8.8.1 SHOW-FLASH

Syntax: **SHOW-FLASH**

Reports status information about Flash memory in the 6TD.

For example, here is the output from **SHOW-FLASH** for a new system with 8 × 64Mb chips fitted:

```
show-flash FILESTORE C 0000FFFF00000000  
FILESTORE K 1048160  
Last Flush: CHIP - -1 0000FFFF  
Last write: CHIP - 35 00000FF8 ok
```

The first two lines display internal diagnostic information, whilst the last two lines describe the position of the read (where data were last flushed) and write (where data were last written) pointers in Flash.

8.8.2 DOWNLOAD

Syntax: **DOWNLOAD** (but see below)

Sets up a data transfer from the Flash memory over the serial connection. Which data are downloaded depends on various parameters you can set, allowing you to select a particular stream, streams of a specified sample rate, or streams within a certain time window. You can set parameters separately, or place the definitions before the **DOWNLOAD** command, e.g.

```
ALL-FLASH HPA0N1 STREAM DOWNLOAD  
2004 12 01 00 00 FROM-TIME ALL-DATA DOWNLOAD  
100 S/S ALL-TIMES DOWNLOAD  
ALL-DATA ALL-TIMES DOWNLOAD
```

Before **DOWNLOAD** will work, it needs to know

- the desired time period, which is specified with **ALL-FLASH**, **ALL-TIMES**, or **FROM-TIME** and/or **TO-TIME**, and
- the streams you want to download, which are specified with **ALL-DATA**, **S/S**, or **STATUS-ONLY**.

The parameters are fully described in the following sections. If you miss out a parameter, **DOWNLOAD** will use the value you last used.

The **DOWNLOAD** command returns immediately, so that you can issue more commands if required. To close the connection and begin downloading, issue the **GO** command.

You can pause a download by entering terminal mode, and restart with another **GO** or abort with **END-DOWNLOAD**.

When you complete a **DOWNLOAD** without specifying a time period, the 6TD marks the latest position with an internal read pointer, which can be used as a start point for the next **DOWNLOAD** with the command **ALL-TIMES** (see below).

8.8.3 FROM-TIME

Syntax: **yyyy mm dd hh mm FROM-TIME**

Instructs the 6TD to transmit only data more recent than **yyyy mm dd hh mm**, where

- **yyyy** is a four-digit year (1989 – 2069);
- **mm** is the month number (1 – 12);

- *dd* is the day of the month (1 – 31);
 - *hh* is the hour of the day (0 – 23); and
 - *mm* is the minute of the hour (0 – 59).
-

8.8.4 TO-TIME

Syntax: *yyyy mm dd hh mm TO-TIME*

Instructs the 6TD to transmit only data earlier than *yyyy mm dd hh mm*, where *yyyy*, *mm*, *dd*, *hh* and *mm* have the same meanings as in `FROM-TIME`, above.

You can combine `FROM-TIME` with `TO-TIME` to download data from a specific time window.

When a `TO-TIME` download completes, the read pointer will be moved to the end of the downloaded data. The old position of the read pointer is forgotten, so issuing `ALL-TIMES` may transmit data you have previously downloaded.

8.8.5 ALL-TIMES

Syntax: `ALL-TIMES`

Clears any time selection in force. The next `DOWNLOAD` will begin at the read pointer, and end with the newest data. When it has finished, the read pointer will be moved to the end of the downloaded data.

8.8.6 ALL-FLASH

Syntax: `ALL-FLASH`

Moves the read pointer to the oldest data held by the 6TD, and sets up the `DOWNLOAD` to transfer all data since that time.

This command does not alter which streams are to be transmitted; you should specify streams or use the `ALL-DATA` command in addition to this one.

When you issue `ALL-FLASH`, the old position of the read pointer is forgotten. Issuing `ALL-TIMES` will not restore it.

8.8.7 ALL-DATA

Syntax: `ALL-DATA`

Instructs the 6TD to transmit all the data streams it holds next time a `DOWNLOAD` is issued. This command does not alter the read pointer or specify a time period.

8.8.8 STREAM

Syntax: **STREAM** *stream-id* (n.b.)

Instructs the 6TD to transmit only the stream with ID *stream-id*. Stream IDs are normally a 4-character device code (e.g. HPA0) followed by a component letter (N) and a tap number (1).



Note: Unlike most FORTH commands, the *stream-id* parameter goes after the command.

The read pointer will be moved to the end time of the download, so a subsequent `ALL-TIMES DOWNLOAD` will not transfer any other streams that were recorded during this period. To retrieve these streams, you will have to specify the time period explicitly with `FROM-TIME` (and `TO-TIME` if necessary), or download all stored data with `ALL-FLASH`.

8.8.9 STATUS-ONLY

Syntax: **STATUS-ONLY**

Instructs the 6TD to transmit only status streams (text streams, normally with stream IDs ending in 00).

The read pointer will be moved to the end time of the download, so a subsequent `ALL-TIMES DOWNLOAD` will not transfer any data streams that were recorded during this period. To retrieve these streams, you will have to specify the time period explicitly with `FROM-TIME` (and `TO-TIME` if necessary), or download all stored data with `ALL-FLASH`.

8.8.10 S/S

Syntax: **rate S/S**

Instructs the 6TD to transmit only streams with sample rates equal to *rate*. If *rate* is zero, only status streams are transmitted.

The read pointer will be moved to the end time of the download, so a subsequent `ALL-TIMES DOWNLOAD` will not transfer any other streams that were recorded during this period. To retrieve these streams, you will have to specify the time period explicitly with `FROM-TIME` (and `TO-TIME` if necessary), or download all stored data with `ALL-FLASH`.

This command should not be confused with the `SAMPLES/SEC` command.

8.8.11 FLUSH

Syntax: **FLUSH**

Instructs the 6TD to copy all new data from Flash memory to an attached FireWire disk. The read pointer is moved to the end of the last data transferred, so a subsequent **FLUSH** will not transfer the same data.

8.8.12 FLUSHALL

Syntax: **FLUSHALL**

Instructs the 6TD to copy all data from Flash memory to an attached FireWire disk. This command ignores the read pointer, so a subsequent **FLUSHALL** will transfer the same data again.

8.8.13 RESET-DISK

Syntax: **RESET-DISC** | **RESET-DISK**

6TDs require Firewire disks to be in DFD format. This command formats or re-formats a Firewire disc by writing a blank File Allocation Table, so that it appears to contain no files. You will be asked for confirmation before the operation proceeds.

In emergencies, you may be able to recover data from a disk which has been erroneously reset by dumping the disk contents directly onto your computer (with **dd** or a similar direct read tool), as long as you have not allowed new data to overwrite the old.

If there is no disk connected, or the cable is faulty, you will see the message **FW Ierr.**

8.8.14 DIR

Syntax: **DIR**

Prints the contents of a Firewire disk. Typical output looks like this:

```
%823FFFC0 N00000002
V31333934
Logon0000C000 00000000
@L00000000,00100000,0000FFC0
AGENT 00100000 lun 00000000 target 0000FFC1
FW INIT
DISKSIZE K 125034840
STREAM | Start | finish | length
384400 18 | 2017 04 05 10:09:26 | 1177712 | 2017 04 07 10:07:30 | 1177696
384400 1177714 | 2017 04 07 10:07:30 | 2959312 | 2017 04 10 08:30:42 | 1781600
384400 2959314 | 2017 04 10 08:30:41 | 3561808 | 2017 04 11 08:33:31 | 602496
384400 3561810 | 2017 04 11 08:33:31 | 4163568 | 2017 04 12 08:18:38 | 601760
384400 4163570 | 2017 04 12 08:18:40 | 4777040 | 2017 04 13 08:31:55 | 613472
Diskfree (sectors) 245292480
Diskfree (MB) 119771
```

The initial diagnostic information is followed by one line per session (where a session is a single flush from an instrument) showing the Stream ID, the starting sector, the earliest time-stamp in the session, the finishing sector, the latest time-stamp in the session and the length of the session in sectors.

The last two lines show the total size of the disk, in sectors, and the remaining space in MB.

When considering free capacity, note that three streams of 100 sps data typically consumes around 50 MB of disk space per day. Doubling or halving the sample rate doubles or halves the amount of space consumed. The actual amount used depends on how compressible the data are: the absolute maximum is around double the typical value but this is rarely seen in practice.

8.8.15 RESET-FLASH

Syntax: **RESET-FLASH**

Resets the Flash memory pointers. The 6TD will start overwriting old data from the beginning of memory. You can still access these data, if they have not been overwritten.

8.8.16 ERASEFILE

Syntax: **ERASEFILE** (interactive)

Clears the entire Flash memory. When you issue this command, the 6TD will ask you for confirmation. Key **Y** to confirm.

You will not be able to access any data previously held in Flash memory after issuing this command.

9 Updating the 6TD firmware

The firmware of the 6TD can be updated remotely over its output port.

In Scream!'s main window, right-click on the instrument's icon and select Terminal... from the pop-up menu. (If this fails, connect the instrument directly to a serial port and right-click on the serial port instead.)

Check that there is two-way communication with the digitiser by pressing Enter. The instrument should reply with ok on a new line.

Type `ok-1` to enable advanced commands. The instrument will reply with a message describing the current firmware version.

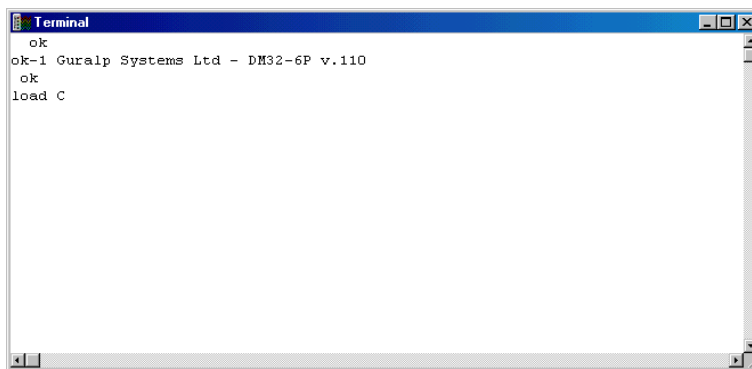

If the firmware needs updating:

1. Type `load` and press ENTER. The instrument will display

```
load C
```

The instrument will now wait up to ten seconds for you to provide a firmware file.

2. Right-click on the terminal window and select **Send file...**:

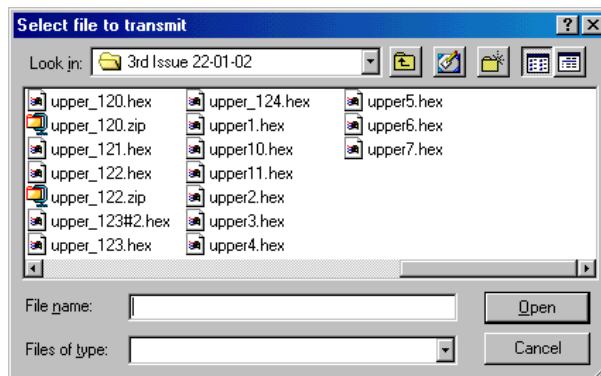

Firmware updates for the 6TD normally have file-names like `uppern_319.hex`.

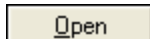
3. Choose the required firmware image file and click .

- If the file opens successfully, Scream! will show the progress of the upload:

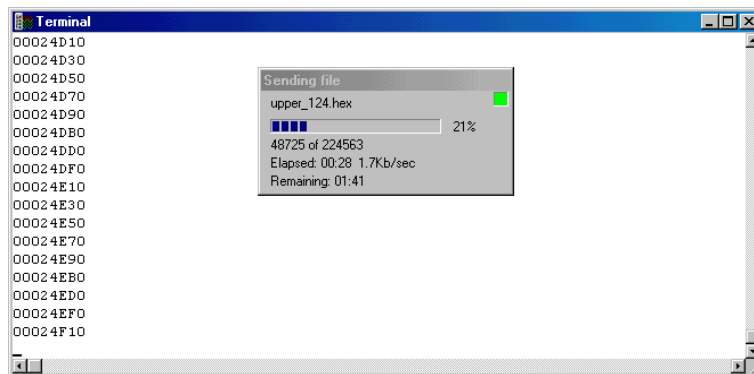

Depending on the speed of the link, it may take up to twenty minutes to transfer the firmware.

- When the transfer completes, type `re-boot` to restart the 6TD.

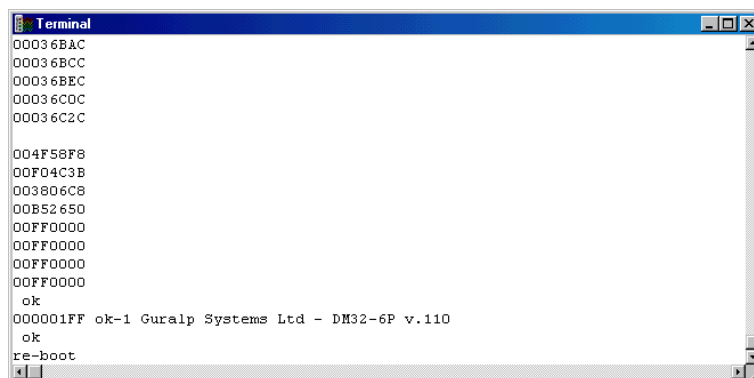

Scream responds with

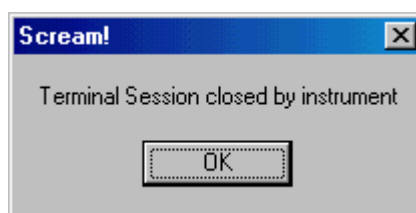

Click to continue.

- At this point you may want to switch the 6TD off and then back on, to ensure that it restarts properly.

Allow thirty seconds for the instrument to restart.

- Right-click on the instrument's icon (📡) in Scream! and select **Configure...** Check that the reported software version corresponds to the version you have just uploaded.

10 Connector pin-outs

10.1 Instrument connectors

10.1.1 Instrument output port

This is a standard 19-pin military-specification bayonet plug, conforming to MIL-DTL-26482 (formerly MIL-C-26482). A typical part-number is 02E-14-19P although the initial "02E" varies with manufacturer.

Suitable mating connectors have part-numbers like ***-14-19S and are available from Amphenol, ITT Cannon and other manufacturers.



Pin	Function	Pin	Function
A	Power + 10 to 36 V	L	Isolated ground
B	Power 0 V	M	Isolated power 0 V for GPS
C	RS232 transmit	N	Lantronix channel 1 (RS232) transmit
D	RS232 receive	P	Lantronix channel 1 (RS232) receive
E	RTS	R	External trigger output terminal
F	CTS	S	External trigger output link, normally closed
G	Isolated power +5V for GPS	T	External trigger output link, normally open
H	GPS transmit	U	External trigger input +ve
J	GPS receive	V	External trigger input - ve
K	GPS PPS		

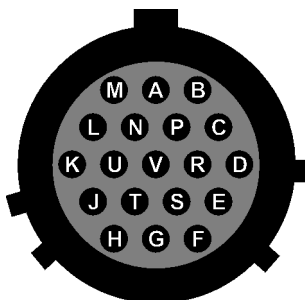

Wiring details for the compatible socket, ***-14-19S, as seen from the cable end (i.e. when assembling).

10.1.2 Instrument *FIREWIRE* port

Instruments with the FireWire option have an additional connector for this purpose.

This is a standard 6-pin military-specification bayonet plug, conforming to MIL-DTL-26482 (formerly MIL-C-26482). A typical part-number is 02E-10-06P although the initial "02E" varies with manufacturer.

Suitable mating connectors have part-numbers like ***-10-06S and are available from Amphenol, ITT Cannon and other manufacturers.



Pin	Function	Firewire pin (4-pin connector)	Firewire pin (6-pin connector)
A	Ground	connector casing	connector casing
B	TPA +ve	4	6
C	TPA -ve	3	5
D	TPB -ve	1	3
E	TPB +ve	2	4
F	<i>not connected</i>		

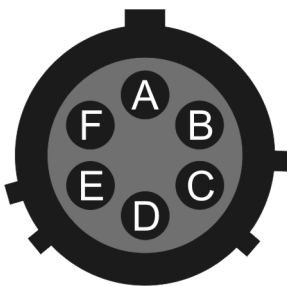

Wiring details for the compatible socket, ***-10-06S, as seen from the cable end (i.e. when assembling).

10.1.3 Instrument *ETHERNET* port

Instruments with the Wi-Fi and Ethernet networking options have an additional 6-pin mil-spec plug (02E-10-06P) for this interface.

This is a standard 6-pin military-specification bayonet plug, conforming to MIL-DTL-26482 (formerly MIL-C-26482). A typical part-number is 02E-10-06P although the initial "02E" varies with manufacturer.

Suitable mating connectors have part-numbers like ***-10-06S and are available from Amphenol, ITT Cannon and other manufacturers.



Pin	Function
A	<i>not connected</i>
B	Data transmit +ve (RJ45 pin 1)
C	Data receive +ve (RJ45 pin 3)
D	<i>not connected</i>
E	Data receive -ve (RJ45 pin 6)
F	Data transmit -ve (RJ45 pin 2)

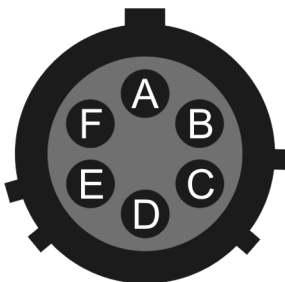

Wiring details for the compatible socket, ***-10-06S, as seen from the cable end (i.e. when assembling).

10.1.4 Instrument Wi-Fi antenna connection

Instruments with the Wi-Fi networking option have an additional connector which may be used with the supplied Wi-Fi stub antenna or connected via a suitable 50 Ω cable (such as RG58) to a high-gain antenna, as required.

This is a standard, reverse-polarity, female SMA connector (female connector body – i.e. with outside threads - with a male inner pin contact), conforming to MIL-PRF-39012 (formerly MIL-C29012).

Suitable mating connectors are available from Amphenol, Cinch, Johnson and other manufacturers. Typical part numbers are:

- Amphenol RSMA1111A1-3GT50G-1-50
- Cinch 142-4303-401
- Johnson 142-4307-401



Pin		Function
Centre		Signal
Outer		Ground

10.2 Breakout box connectors

The break-out box connections are arranged as shown in the following diagram:

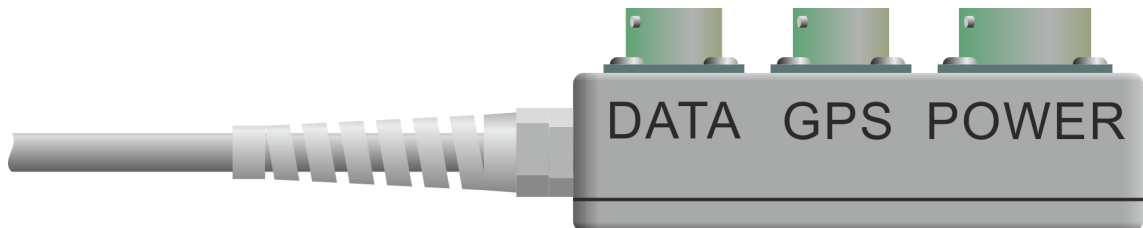

The individual connectors are described in the following sections.

10.2.1 Breakout box data port

This is a standard 6-pin military-specification bayonet plug, conforming to MIL-DTL-26482 (formerly MIL-C-26482). A typical part-number is 02E-10-06P although the initial "02E" varies with manufacturer.

Suitable mating connectors have part-numbers like ***-10-06S and are available from Amphenol, ITT Cannon and other manufacturers.



Pin	Function
A	RS232 transmit
B	RS232 receive
C	RTS
D	CTS
E	<i>not connected</i>
F	Isolated ground

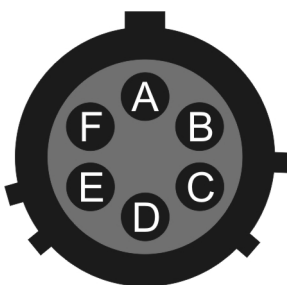

Wiring details for the compatible socket, ***-10-06S, as seen from the cable end (i.e. when assembling).

10.2.2 Breakout box GPS port

This is a standard 6-pin military-specification bayonet socket, conforming to MIL-DTL-26482 (formerly MIL-C-26482). A typical part-number is 02E-10-06S although the initial "02E" varies with manufacturer.

Suitable mating connectors have part-numbers like ***-10-06P and are available from Amphenol, ITT Cannon and other manufacturers.



Pin	Function
A	Isolated ground
B	RS232 receive from GPS
C	RS232 transmit to GPS
D	PPS
E	<i>not connected</i>
F	Power +5 V

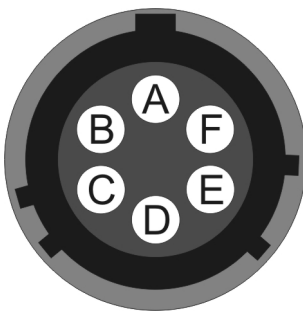

Wiring details for the compatible plug, ***-10-06P, as seen from the cable end (i.e. when assembling).

10.2.3 Breakout box power port

This is a standard 10-pin military-specification bayonet plug, conforming to MIL-DTL-26482 (formerly MIL-C-26482). A typical part-number is 02E-12-10P although the initial "02E" varies with manufacturer.

Suitable mating connectors have part-numbers like ***-12-10S and are available from Amphenol, ITT Cannon and other manufacturers.



Pin	Function
A	0V
B	+12 V DC supply
C	<i>not connected</i>
D	<i>not connected</i>
E	<i>not connected</i>
F	<i>not connected</i>
G	<i>not connected</i>
H	<i>not connected</i>
J	<i>not connected</i>
K	<i>not connected</i>



Wiring details for the compatible socket, ***-12-10S, as seen from the cable end (i.e. when assembling).



Caution: Observe the correct polarity when connecting the power supply. The **red** lead (from pin B) must be connected to the **positive terminal**, typically labelled '+', and the **black** lead (from pin A) must be connected to the **negative terminal**, typically labelled '-'. An incorrect connection risks destroying both the instrument and the power supply.

11 Specifications

Outputs and response	Sensitivity	2000 V/ms ⁻¹
	Nominal output sensitivity	2.0 × 10 ⁻⁹ ms ⁻¹ /count
	Standard output format	24-bit
	Noise-free resolution (NPR) at 20 samples/s	> 132 dB r.m.s. (> 22 bits)
	Standard frequency band	0.033 Hz (30 s) – 100 Hz
	Digital signal processor	TMS3200 at 144 MHz
	Output rate	User selectable
	RS232 baud rate	User selectable
Physical	Lowest spurious resonance	450 Hertz
	Operating temperature range	-10 to +75 °C
	Pressure jacket material	hard anodised aluminium
	Internal thermometer accuracy	±0.33 °C (30 °C)
		±0.5 °C (10..50 °C) ±1.0 °C (-10..75 °C)
	Internal thermometer linearity	±0.5 °C
	Internal thermometer resolution	0.0625 °C
	Sensor base plate	hard anodised aluminium
	Base diameter	154 mm
	Sensor height	242 mm (including handle)
Sensor weight	3.0 kg	
Power	Voltage requirements	10 to 24 Volts DC, using 12 V DC/DC converter
	Current at 12 V DC with GPS	165 mA

12 Revision history

2017-04-12	J	Reformatted for new branding. Added DIR command. Enhanced explanation of downloading via the serial port. Added warnings about power supply connections and GPS time to fix.
2015-09-28	H	Added reference to "Receive UDP data" in Scream. Corrected minor formatting errors and improved graphics.
2014-04-25	G	Removed references to 60-second instruments, added RESET-DISK command and clarified disk-format details.
2014-02-03	F	Clarified details of Lantronix architecture and configuration via serial port. Minor re-write and re-format.
2012-02-29	E	Corrected misprint in break-out box DATA connector pin-out.
2009-09-14	D	Replaced ReadSCSI section with gcfxtract details.
2009-09-09	C	Clarified positions of optional connectors; improved connector pin-out pages
2006-10-02	B	Added revision history; changes for CD24 digitiser; Wi-Fi and Ethernet options
2005-06-02	A	New document