

Güralp Minimus and Minimus+

including Güralp Discovery software and the GüVü app

Technical Manual

Document Number: MAN-MIN-0001

Issue B 29/02/2024 20:11:53

1	Preliminary Notes	10
1.1	Proprietary Notice.....	11
1.2	Cautions and Notes	11
1.3	Manuals and Software	11
1.4	Conventions.....	11
2	System Overview	11
2.1	Key features.....	12
2.2	Typical applications.....	12
3	System description	13
3.1	Güralp Minimus digitiser	13
3.1.1	LED indicator	14
3.1.2	Bluetooth connectivity.....	15
3.1.3	Data storage.....	15
3.1.3.1	Primary (hot-swappable) microSD card – new style	16
3.1.3.2	Primary (hot-swappable) microSD card – old style	17
3.1.3.3	Internal (back-up) microSD card.....	20
3.1.4	Web interface	20
3.2	Accessory package	21
3.2.1	Ethernet cable.....	21
3.2.2	Compact GNSS receiver and cable.....	21
3.2.3	Power cable	22

Güralp Minimus and Minimus+

3.2.4	Diagnostic GNSS to Serial cable adapter	22
3.3	Güralp Discovery software	22
3.4	Güralp GüVü Android and iOS app	23
4	Getting started	24
4.1	System set-up	24
4.2	Güralp Discovery software installation	25
4.3	Viewing waveforms and system state-of-health	29
4.3.1	Using Discovery's "Live View" window	29
4.3.1.1	Main features	29
4.3.1.2	Window control short-cuts	32
4.3.1.3	GDI connection settings	32
4.3.1.4	Backfill from microSD card	33
4.3.2	Using Scream!	34
5	System configuration	36
5.1	Web Page login	36
5.2	System status	37
5.3	Station meta-data	38
5.4	Network configuration	39
5.4.1	I.P. address and gateway	39
5.4.2	NTP (Network Timing Protocol) configuration	40
5.5	GDI push (auto-connection)	40
5.6	QSCD	41
5.7	Data storage	42
5.8	Storage	43
5.8.1	Recording status	43
5.8.2	MicroSD card re-formatting	44
5.8.2.1	Quick format	45
5.8.2.2	Full format	45
5.8.3	MicroSD card data flushing and unmounting	45
5.8.4	Downloading recorded data	45
5.8.5	Downloading data for specific time-intervals	47
5.8.6	Bulk data extraction	48

Güralp Minimus and Minimus+

5.8.7	The contents of the microSD card	48
5.8.8	Request data from microSD card	51
5.9	Data transmission	54
5.9.1	Scream! (GCF format + Scream protocol)	55
5.9.2	GDI-link protocol	56
5.9.3	SEEDlink protocol	56
5.9.3.1	MiniSEED extractor	60
5.10	Synchronisation of the sample-clock	61
5.10.1	GNSS lock status	62
5.10.2	PTP (Precision Time Protocol)	63
5.10.2.1	Special notes for PTP with Maris ocean-bottom systems.	65
5.11	Deploy mode: Full power-save	66
5.12	Configuration and control of connected analogue instruments	68
5.12.1	Setting instrument type	68
5.12.2	Setting instrument (sensor) gain for Güralp Fortis	68
5.12.3	Setting digitiser gain	69
5.12.4	Mass control	69
5.12.4.1	Mass centring	69
5.12.4.2	Mass locking	69
5.12.5	Instrument response parameters	70
5.13	Configuration and control of connected digital instruments	75
5.14	Setting sensor orientation and depth parameters	75
5.14.1	Applied rotation	75
5.14.2	Instrument installation parameters	75
5.14.3	Inject a calibration signal	76
5.15	Transforms	77
5.15.1	Pass-through	79
5.15.2	Differentiation	79
5.15.3	1 st order LPF	80
5.15.4	1 st Order HPF	80
5.15.5	1 st Order Band/Notch filter	81
5.15.6	2 nd Order biquad	82
5.15.7	Integration	82

Güralp Minimus and Minimus+

5.15.8	Double Integration	83
5.15.9	EEW Parameters – Observer	84
5.15.10	STA/LTA Ratio	86
5.15.11	Three-dimensional Rotation	87
5.15.12	QSCD Sender (triplet)	89
5.15.13	MMA Logger	90
5.16	Earthquake Early Warning	91
5.16.1	Trigger sources	91
5.16.2	Trigger destinations	95
5.16.3	Low Latency Mode	98
5.16.4	CAP Receiver	98
5.16.5	Seismic Event Table	101
5.17	Using a Registry	103
5.17.1	Configuring Discovery for use with a registry	104
5.17.2	Registry mode: using WAN or LAN addresses	105
5.18	Updating Minimus firmware.....	107
5.19	Import / Export an existing configuration	111
5.20	Control Centre	113
6	Scripting	114
6.1	Enabling.....	114
6.2	Sending a script file	115
6.3	Commands within the script file	116
6.4	Example to instigate calibration	116
6.5	Status of the script running process	117
6.6	Example futrcmds.txt file	117
6.6.1	0:Calibration 4.....	118
6.6.2	0:Lookup generator gain 0	118
6.6.3	0:Channel 5	118
6.6.4	0:Lookup generator gain 1106247680	118
6.6.5	0:Lookup generator gain 0	118
6.6.6	0:Channel 0	118
6.6.7	0:Calibration 0.....	118
7	GüVü app	118

Güralp Minimus
and Minimus+

7.1	Getting stated.....	118
7.2	Selecting data sources.....	121
7.3	View settings.....	121
7.4	Instrument control.....	122
7.4.1	Setting the PIN code.....	123
7.5	Emailing a deployment report.....	123
8	<i>Advanced troubleshooting</i>	126
8.1	Reset all settings during boot phase.....	127
9	<i>Appendix 1 – Instrument/channel names</i>	135
9.1	Minimus' internal sensors.....	136
9.2	Analogue Instruments.....	138
9.3	Digital Instruments.....	139
10	<i>Appendix 2 – Minimus network ports</i>	141
11	<i>Appendix 3 – Connector pin-outs</i>	141
11.1	Ethernet.....	141
11.2	Power.....	142
11.3	GNSS/serial.....	143
11.4	Digital.....	144
11.5	Analogue 1 and Analogue 2.....	145
12	<i>Appendix 4 – Dimensions and drawings</i>	146
12.1	Minimus.....	146
12.2	Minimus+.....	147
13	<i>Appendix 5 – Güralp Discovery installation</i>	147
13.1	Installation in Linux.....	148
13.2	Installation in Mac.....	149
13.3	Installation in Windows.....	151
13.4	Configuring Windows Firewall.....	154
13.5	Update.....	158
14	<i>Appendix 6 – I.P. address configuration on PC or Laptop</i>	161
14.1	On Linux.....	161
14.2	On macOS.....	162
14.3	On Windows.....	163

Güralp Minimus and Minimus+

15	<i>EU Declaration of Conformity</i>	163
16	<i>Revision History</i>	165
	<i>Preliminary Notes</i>	10
	Proprietary Notice	11
	Cautions and Notes	11
	Manuals and Software	11
	Conventions	11
	<i>System Overview</i>	11
	Key features	12
	Typical applications	12
	<i>System description</i>	13
	Güralp Minimus digitiser	13
	LED indicator	14
	Bluetooth connectivity	15
	Data storage	15
	Primary (hot-swappable) microSD card – new style	16
	Primary (hot-swappable) microSD card – old style	17
	Internal (back-up) microSD card	20
	Web interface	20
	Accessory package	21
	Ethernet cable	21
	Compact GNSS receiver and cable	21
	Power cable	22
	Diagnostic GNSS to Serial cable adapter	22
	Güralp Discovery software	22
	Güralp GüVü Android and iOS app	23
	<i>Getting started</i>	24
	System set-up	24
	Güralp Discovery software installation	25
	Viewing waveforms and system state-of-health	29
	Using Discovery’s “Live View” window	29
	Main features	29

Güralp Minimus and Minimus+

Window control short-cuts.....	32
GDI connection settings	32
Backfill from microSD card	33
Using Scream!	34
System configuration.....	36
Web Page login	36
System status.....	37
Station meta-data	38
Network configuration	39
I.P. address and gateway.....	39
NTP (Network Timing Protocol) configuration	40
GDI push (auto-connection).....	40
QSCD	41
Data storage	42
Storage	43
Recording status.....	43
MicroSD card re-formatting	44
Quick format.....	45
Full format	45
MicroSD card data flushing and unmounting	45
Downloading recorded data.....	45
Downloading data for specific time-intervals	47
Bulk data extraction	48
The contents of the microSD card.....	48
Request data from microSD card	51
Data transmission	54
Scream! (GCF format + Scream protocol)	55
GDI-link protocol	56
SEEDlink protocol	56
MiniSEED extractor.....	60
Synchronisation of the sample-clock.....	61
GNSS lock status.....	62
PTP (Precision Time Protocol)	63

Güralp Minimus
and Minimus+

Special notes for PTP with Maris ocean-bottom systems. 65

Deploy mode: Full power-save 66

Configuration and control of connected analogue instruments 68

Setting instrument type 68

Setting instrument (sensor) gain for Güralp Fortis 68

Setting digitiser gain 69

Mass control 69

 Mass centring 69

 Mass locking 69

Instrument response parameters 70

Configuration and control of connected digital instruments 75

Setting sensor orientation and depth parameters 75

Applied rotation 75

Instrument installation parameters 75

Inject a calibration signal 76

Transforms 77

Pass-through 79

Differentiation 79

1st order LPF 80

1st Order HPF 80

1st Order Band/Notch filter 81

2nd Order biquad 82

Integration 82

Double Integration 83

EEW Parameters – Observer 84

STA/LTA Ratio 86

Three-dimensional Rotation 87

QSCD Sender (triplet) 89

MMA Logger 90

Earthquake Early Warning 91

Trigger sources 91

Trigger destinations 95

Low Latency Mode 98

Güralp Minimus and Minimus+

CAP Receiver	98
Using a Registry	103
Configuring Discovery for use with a registry	104
Registry mode: using WAN or LAN addresses	105
Updating Minimus firmware.....	107
Import / Export an existing configuration	111
Control Centre	113
Scripting	114
Enabling.....	114
Sending a script file	115
Commands within the script file	116
Example to instigate calibration	116
Status of the script running process	117
Example futrcmds.txt file	117
0:Calibration 4	118
0:Lookup generator gain 0	118
0:Channel 5	118
0:Lookup generator gain 1106247680	118
0:Lookup generator gain 0	118
0:Channel 0	118
0:Calibration 0	118
GüVü app.....	118
Getting stated.....	118
Selecting data sources.....	121
View settings	121
Instrument control.....	122
Setting the PIN code.....	123
Emailing a deployment report	123
Advanced troubleshooting.....	126
Reset all settings during boot phase	127
Appendix 1 – Instrument/channel names	135
Minimus' internal sensors	136

Güralp Minimus and Minimus+

Analogue Instruments	138
Digital Instruments	139
<i>Appendix 2 – Minimus network ports</i>	<i>141</i>
<i>Appendix 3 – Connector pin-outs</i>	<i>141</i>
Ethernet	141
Power	142
GNSS/serial.....	143
Digital.....	144
Analogue 1 and Analogue 2	145
<i>Appendix 4 – Dimensions and drawings</i>	<i>146</i>
Minimus	146
Minimus+	147
<i>Appendix 5 – Güralp Discovery installation.....</i>	<i>147</i>
Installation in Linux.....	148
Installation in Mac	149
Installation in Windows.....	151
Configuring Windows Firewall	154
Update	158
<i>Appendix 6 – I.P. address configuration on PC or Laptop</i>	<i>161</i>
On Linux	161
On macOS.....	162
On Windows	163
<i>EU Declaration of Conformity</i>	<i>163</i>
<i>Revision History</i>	<i>165</i>

1 Preliminary Notes

Güralp Minimus and Minimus+

1.1 Proprietary Notice

The information in this document is proprietary to Güralp Systems Limited and may be copied or distributed for educational and academic purposes but may not be used commercially without permission.

Whilst every effort is made to ensure the accuracy, completeness and usefulness of the information in the document, neither Güralp Systems Limited nor any employee assumes responsibility or is liable for any incidental or consequential damages resulting from the use of this document.

1.2 Cautions and Notes

Cautions and notes are displayed and defined as follows:

Caution: A yellow triangle indicates a chance of damage to or failure of the equipment if the caution is not heeded.

Note: A blue circle indicates indicates a procedural or advisory note.

1.3 Manuals and Software

All manuals and software referred to in this document are available from the Güralp Systems website: www.guralp.com unless otherwise stated.

1.4 Conventions

Throughout this manual, examples are given of command-line interactions. In these examples, a fixed-width typeface will be used:

`Example of the fixed-width typeface used.`

Commands that you are required to type will be shown in bold:

Example of the fixed-width, bold typeface.

Where data that you type may vary depending on your individual configuration, such as parameters to commands, these data are additionally shown in italics:

Example of the fixed-width, bold, italic typeface.

Putting these together into a single example:

System prompt: **user input with variable parameters**



2 System Overview

Thank-you for purchasing a Güralp Minimus or Minimus+ digitiser.





This section describes the key components of a Minimus system or Minimus+. The Minimus or Minimus+ unit is the main, standard product in the system; other components and accessories are optional and can be purchased separately. Please check your order confirmation to see which components were purchased with your system.

Güralp Minimus and Minimus+

The Minimus has four fully-featured analogue input channels. The Minimus+ is physically wider, with an additional analogue sensor input connector, and provides eight fully-featured analogue input channels. Otherwise, the two units are very similar.

Note: In this document, the symbol  is used to identify information that relates only to the Minimus+ and not to the Minimus. All other information relates to both units, unless obviously contradicted by a clause containing .

2.1 Key features

- 24-bit, four-channel ( eight-channel) digitiser with nominal 2.44 $\mu\text{V}/\text{count}$ sensitivity.
- Compact form, measuring just 134 × 99 × 45 mm ( 134 × 139 × 45 mm) and weighing just 0.67 kg ( 0.78 kg).
- Compatible with all analogue seismic sensors with a voltage output.
- Simultaneously accommodates one ( two) triaxial sensor(s), one ( two) infra-sound sensor(s) and a digital feed from a Radian post-hole or borehole instrument.
- Supports automatic Identification of I.P. addresses via Güralp Discovery software and a cloud-based or organisational registry server.
- Remote instrument and data management via Discovery.
- Bluetooth Android app for installation integrity checking.
- Low-latency mode for Earthquake Early Warning (< 40 ms).
- Hot-swappable data storage with dual redundant microSD cards.
- GNSS time-synchronisation, compatible with Navstar (GPS), GLONASS, Galileo and BeiDou constellations. PTP is available for when GNSS is impractical.

2.2 Typical applications

- Earthquake Early Warning systems.
- Volcanology.
- Multi-scale seismic networks.
- Structural health monitoring.
- Hydrocarbon exploration.

Güralp Minimus and Minimus+

- Permanent reservoir monitoring.
- Induced seismicity detection.
- Explosion monitoring.

3 System description

3.1 Güralp Minimus digitiser

The Güralp Minimus is a combined digitiser and advanced communications unit.

The Minimus acquires data from – and allows direct control (where appropriate) of – connected analogue instruments (*e.g.* Güralp Fortis, 3-series, 5-series, 40T and 6T sensors) and digital instruments (*e.g.* the Güralp Radian).

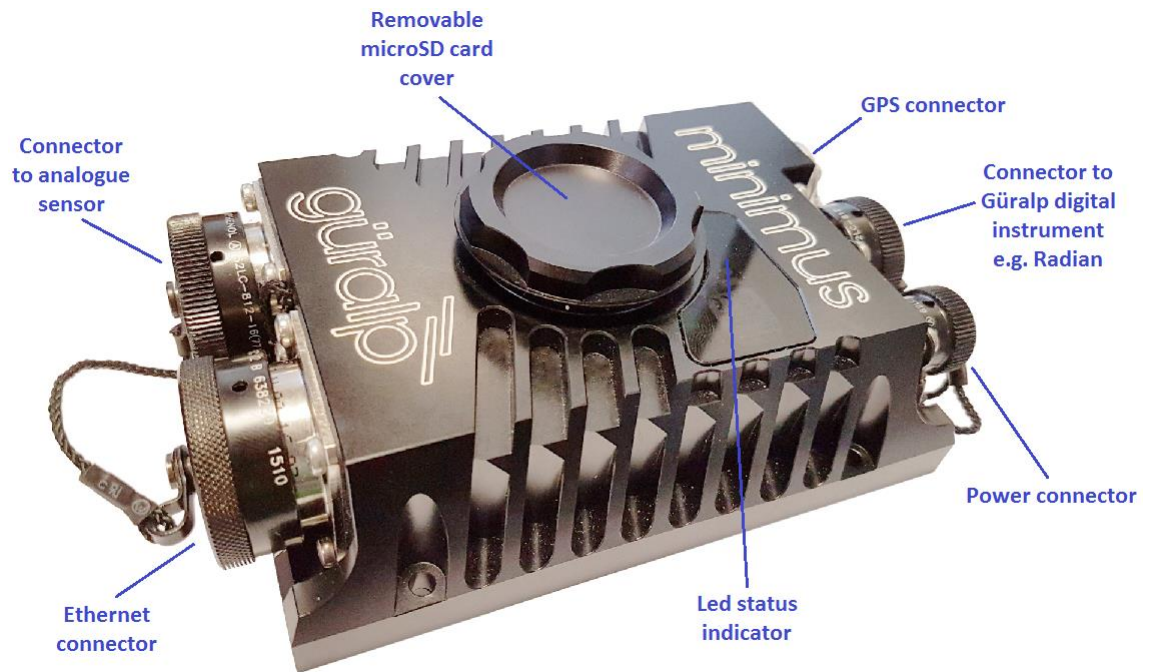

The Güralp Minimus functions as the Surface Interface Unit (SIU) for Radian post-hole instruments in shallow (<100 metres).

⚠ The Minimus+ features an additional analogue sensor connector:



Güralp Minimus
and Minimus+

A full description of the operation, control and configuration of the Güralp Radian instrument via the Minimus is not within the scope of this manual; please refer instead to the Radian manual, **MAN-RAD-0001**.

Caution: Analogue sensors with true floating outputs connected to the Minimus – included geophones, infra sound sensors, pressure gauges, etc. – must have their outputs ground-referenced using a >100 kΩ resistor.

3.1.1 LED indicator

The Minimus has an LED indicator on the upper surface, which provides status and configuration information.



Flashing white rapidly: This occurs from power-up until the 1 kHz clock is set and typically lasts for a period of two to three seconds.



No flashing: This occurs during the boot-up and initialization stages and typically lasts for a period of twenty to thirty seconds.



One quick red flash followed by a one second pause: the removable microSD card is present in the Minimus' external slot, but no fixed microSD card is present inside the Minimus.



Two quick red flashes followed by a one second pause: the fixed microSD card is present inside the Minimus but no removable microSD card is present in the Minimus' externally-accessible slot.



Three quick red flashes following by a one second pause: both microSD cards are present but either the GNSS receiver is disconnected or the GNSS lock is not sufficiently accurate.



A green flash every four seconds: this is the standard operating heartbeat. GNSS and both internal & external microSD cards are present, which indicates that the Minimus can be successfully deployed and left to record data.

Note: Depending on the digitiser's recent history, it can take up to ten minutes to reach this state after power-up.



1 blue flash: a trigger event has been detected.

Güralp Minimus and Minimus+

3.1.2 Bluetooth connectivity

The Minimus features Bluetooth connectivity, allowing sensor and state-of-health data to be monitored using the Güralp GüVü app (see section 3.4 on page **Error! Bookmark not defined.**) on an Android mobile phone or tablet.

The Bluetooth can be disabled via software to save processor usage but the hardware module cannot be switched off. BLE (Bluetooth Low Energy) technology is used to minimise the power requirement. The Bluetooth transmitter/receiver is in permanent standby mode and always ready to receive a connection from a phone or tablet.

See Chapter 6 on page **Error! Bookmark not defined.** for further details on connecting to the Minimus and its attached sensors using a phone or tablet.

3.1.3 Data storage

The Minimus uses microSD (non-volatile) memory technology to store seismic data locally. The Minimus features two such microSD cards in order to provide redundancy; this helps to protect the recorded data in the unlikely event of any corruption or problem with the memory cards. One card is internal and cannot be removed by the customer; the other is hot-swappable and easily accessible without any technical knowledge.

The Minimus is supplied with two microSD cards that are of equal storage capacity (*e.g.* two 64 GB cards).

Note: In order to ensure data integrity and security, Güralp only recommends the use of the supplied industrial-grade microSD cards.

Caution: When the external microSD card is removed, the internal card keeps recording data. However, when the external card is re-connected, any data written to the internal card while the removable card was absent will be overwritten.

Starting from summer 2018, two designs of the card-holder for the removable card became available. The following two sections describe how to change the card in the newer models (section 3.1.3.1 on page 16) and the original models (section 3.1.3.2 on page 17).

Güralp Minimus and Minimus+

3.1.3.1 Primary (hot-swappable) microSD card – new style

The upper surface of the Minimus has a waterproof screw-in card-holder that is sealed by an O-ring.

To insert or replace a microSD card, proceed as follows:

1. Rotate the card-holder in an anti-clockwise direction, unscrewing it from the body of the digitiser..

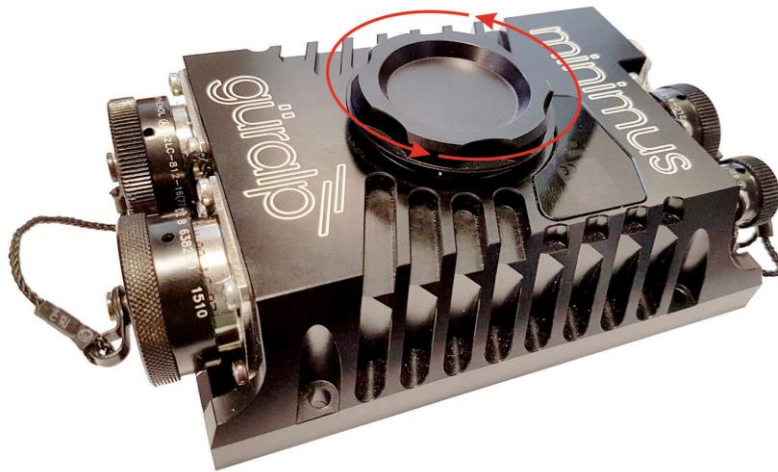

Caution: The card holder connects electrically to the Minimus via a series of slip-rings which ride on metal fingers in the main body of the digitiser:

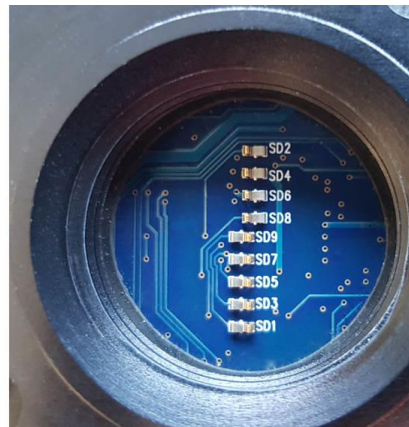
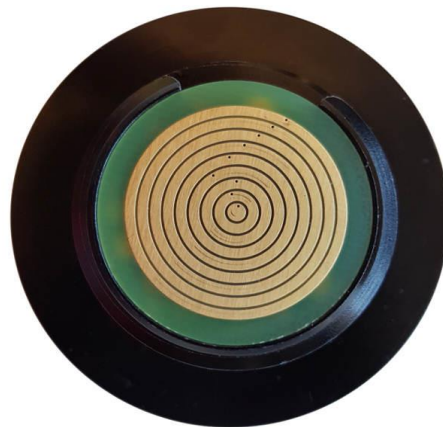

It is very important that the slip-rings and the metal finger-contacts do not become damaged or tarnished. Take care not to touch either part. If a Minimus has had its card-holder removed, do not leave it exposed to the elements. If a card-holder is to be transported when it is not installed in a Minimus, enclose it in a protective bag or covering so that it cannot be scratched or contaminated.

Güralp Minimus and Minimus+

2. The microSD card is accessible via the slot in the side of the card-holder. Using a pair of tweezers, first push the card in gently and then release the pressure: the card will spring outwards a little. It can now be grasped and withdrawn.
3. To insert a new card, line it up with the slot as shown and push it gently into place. Once you feel the spring pressure, continue pushing until more resistance is felt and then release the pressure: the card will lock into place.



4. Finally, replace the cap and rotate clockwise until hand-tight. Do not over-tighten and do not use tools.

3.1.3.2 Primary (hot-swappable) microSD card – old style

Early models of the Minimus had a different arrangement. The upper surface of the Minimus had a waterproof screw-cap that is sealed by an O-ring. This protects the microSD card slot from the environment.

To insert or replace a microSD card in an older Minimus, proceed as follows:

1. To reveal the microSD card slot, rotate the cap in an anti-clockwise direction.

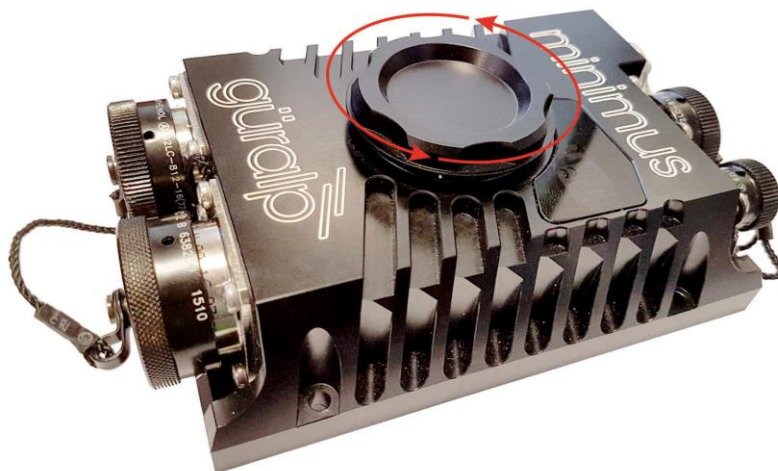

Güralp Minimus
and Minimus+

2. The microSD card is now exposed.
3. To make the microSD card slot available, use your finger to move the card carrier in the "Open" direction:

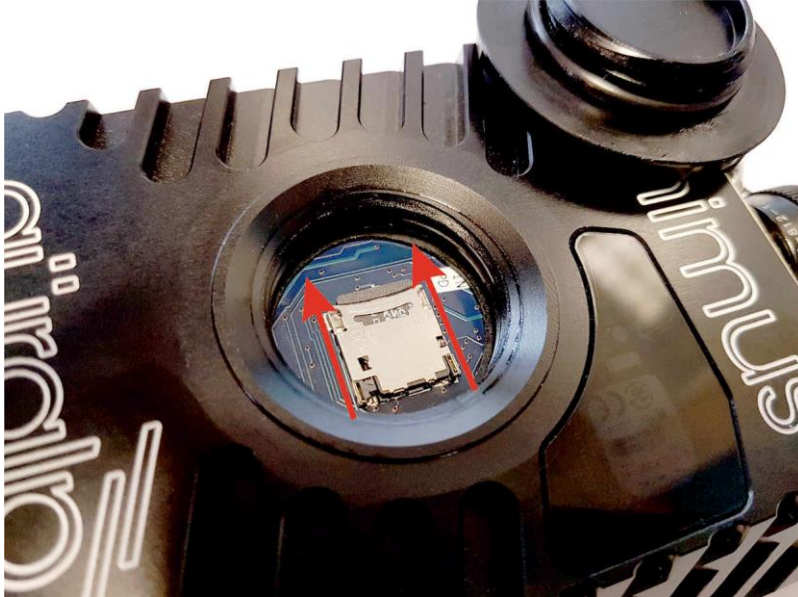

4. Gently lift up the free end of the card carrier, which hinges at the other end, as shown:

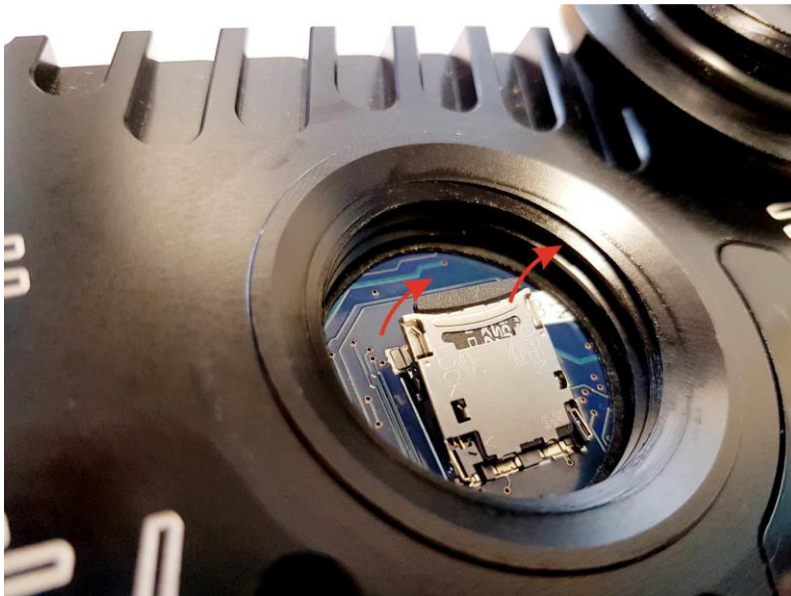

Güralp Minimus
and Minimus+

5. You should now be able to insert/remove a microSD card. The replacement should be positioned so that the gold contacts on the microSD card will be facing downwards when the carrier is hinged back down.

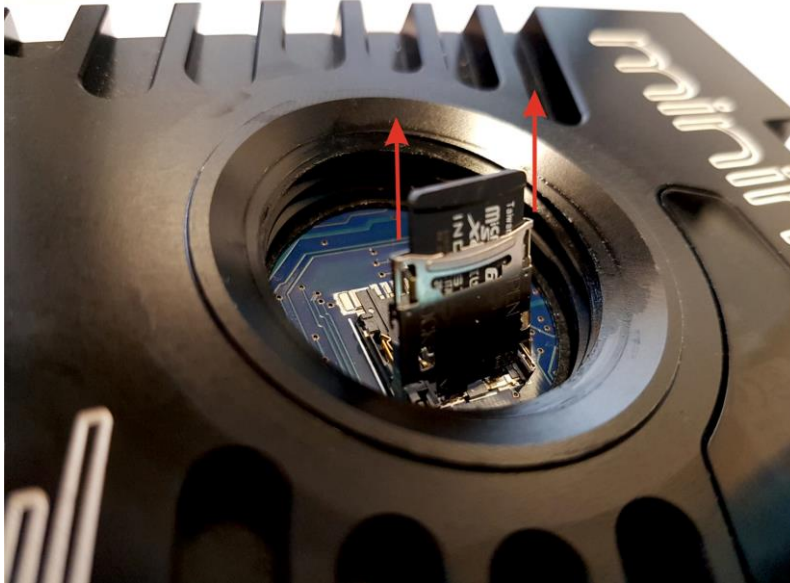

6. Push the hinged carrier firmly down and slide it in the "LOCK" direction:

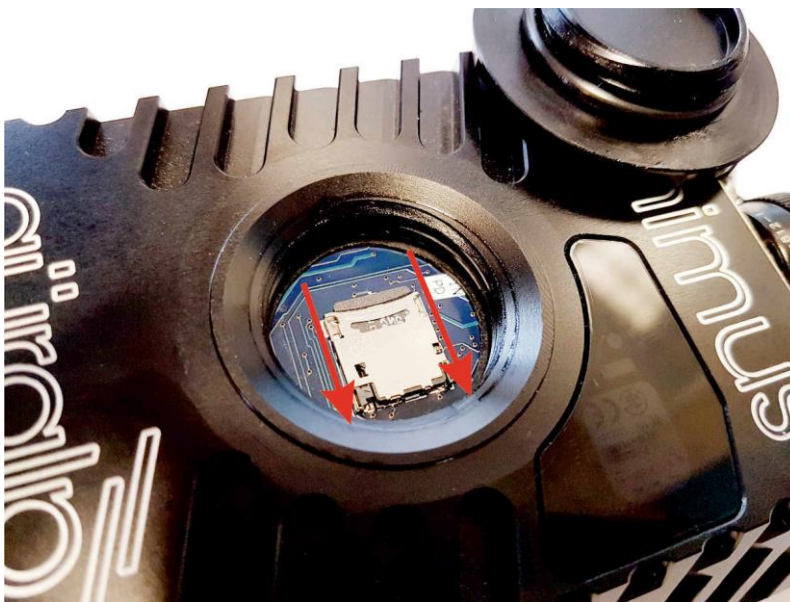

7. Finally, replace the cap and rotate clockwise until hand-tight. Do not over-tighten and do not use tools.

Note: In order to ensure data integrity and security, Güralp only recommends the use of the supplied industrial-grade microSD cards.

Güralp Minimus
and Minimus+

Caution: When the external microSD card is removed, the internal card keeps recording data, unless stopped using the  button (see [Section](#)). However, when the external card is re-connected, any data written to the internal card while the removable card was absent will be overwritten.

3.1.3.3 Internal (back-up) microSD card

The second microSD card is factory-installed in a slot inside the Minimus.

Caution: The internal microSD card is not accessible by the user. Attempts to remove or replace it will void the Minimus' warranty.

3.1.4 Web interface

The Minimus contains on-board firmware that presents monitoring and configuration interfaces. These are accessible through Güralp's Discovery software or, with the built-in web server, via Discovery's browser interface or any standards-conformant web browser.

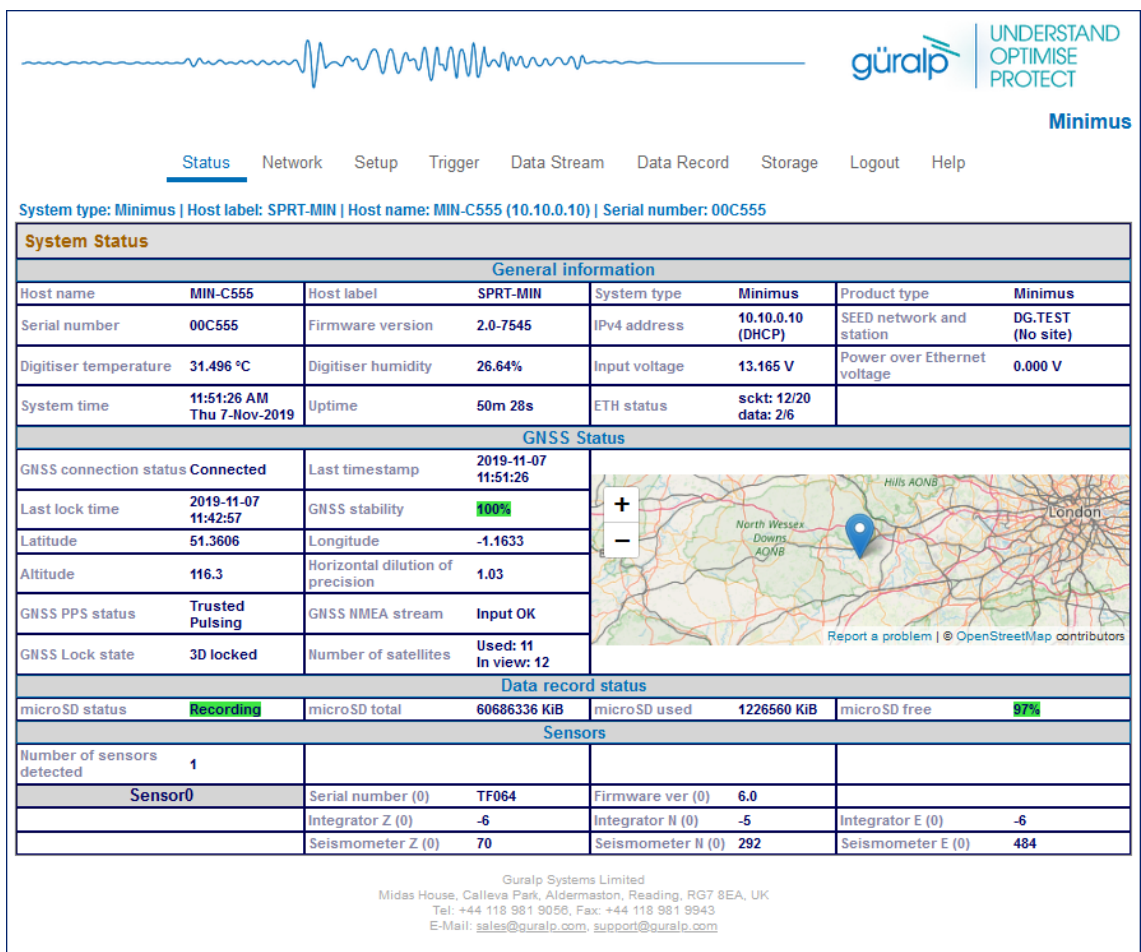

The screenshot shows the Minimus web interface with the following sections:

- System Information:** System type: Minimus | Host label: SPRT-MIN | Host name: MIN-C555 (10.10.0.10) | Serial number: 00C555
- System Status Table:**

General information							
Host name	MIN-C555	Host label	SPRT-MIN	System type	Minimus	Product type	Minimus
Serial number	00C555	Firmware version	2.0-7545	IPv4 address	10.10.0.10 (DHCP)	SEED network and station	DG.TEST (No site)
Digitiser temperature	31.496 °C	Digitiser humidity	26.64%	Input voltage	13.165 V	Power over Ethernet voltage	0.000 V
System time	11:51:26 AM Thu 7-Nov-2019	Uptime	50m 28s	ETH status	skt: 12/20 data: 2/6		
- GNSS Status Table:**

GNSS connection status	Connected	Last timestamp	2019-11-07 11:51:26
Last lock time	2019-11-07 11:42:57	GNSS stability	100%
Latitude	51.3606	Longitude	-1.1633
Altitude	116.3	Horizontal dilution of precision	1.03
GNSS PPS status	Trusted Pulsing	GNSS NMEA stream	Input OK
GNSS Lock state	3D locked	Number of satellites	Used: 11 In view: 12
- Data record status Table:**

microSD status	Recording	microSD total	60686336 KiB	microSD used	1226560 KiB	microSD free	97%
----------------	-----------	---------------	--------------	--------------	-------------	--------------	-----
- Sensors Table:**

Sensors						
Number of sensors detected	1					
Sensor0	Serial number (0)	TF064	Firmware ver (0)	6.0		
	Integrator Z (0)	-6	Integrator N (0)	-5	Integrator E (0)	-6
	Seismometer Z (0)	70	Seismometer N (0)	292	Seismometer E (0)	484

Footer: Güralp Systems Limited, Midas House, Calleva Park, Aldermaston, Reading, RG7 8EA, UK. Tel: +44 118 981 9056, Fax: +44 118 981 9943. E-Mail: sales@guralp.com, support@guralp.com

The web interface allows a number of instrument monitoring, control and configuration options:

Güralp Minimus and Minimus+

- Sensor readings and instrument State-of-Health
- Network configuration and authentication
- Sensor, timing, and station configuration/information
- Remote data-streaming configuration
- Local data-storage configuration

Please refer to Chapter 5 on page **Error! Bookmark not defined.** for full usage instructions.

3.2 Accessory package

3.2.1 Ethernet cable

The Ethernet connector allows use of 10BASE-T, 100BASE-T or 1000BASE-T networks. The cable that connects to the Minimus has a metal cover which is IP68-rated and ensures consistent connections in harsh installation environments. At the other end of the blue Ethernet cable, there is a standard 8P8C modular jack (often incorrectly called an RJ45) for attachment to all common networking devices (*e.g.* PC, laptop, router, switch, modem etc.).

Please see [section](#) for the pin-out and further details.

3.2.2 Compact GNSS receiver and cable

The Minimus is supplied with a new-generation compact GNSS receiver with an in-built antenna that supports the GPS (Navstar), GLONASS, BeiDou and Galileo satellite constellations.

The receiver comes with a black RS-422 cable that has an over-moulded 14-way LEMO connector. LEMO connectors use an innovative latching mechanism which is different to the bayonet connectors used elsewhere. To mate, simply line up the red marks – one on the chassis and one on the free connector – and gently push the connector into place until they latch together with a click. To disconnect (un-mate), grasp the outer sleeve of the connector and pull gently.

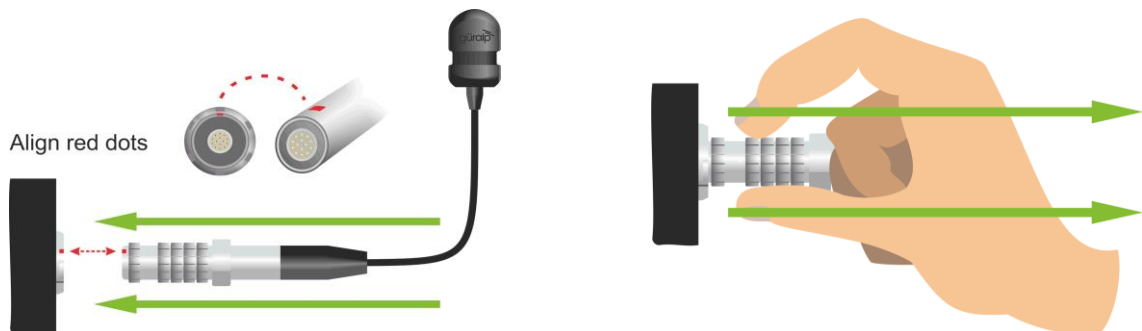

Güralp Minimus and Minimus+

Caution: Do not twist the connector or use any tools.



Please see [section](#) for pin-out details.

3.2.3 Power cable

The Minimus comes with a dedicated power cable with a standard military-specification bayonet connector on one end and bare ends at the other.

Note: The Minimus does not use a grey/blue combined power/data cable, as used with many other Güralp products.

Please see [section](#) for the pin-out details.

Caution: We recommend fitting an in-line 3.5 A anti-surge fuse in the positive power lead to protect the external wiring of the installation.

3.2.4 Diagnostic GNSS to Serial cable adapter

The Minimus comes with an adapter to connect the GNSS LEMO connector to a female nine-pin D-subminiature connector (DE9f), which can be used with a standard serial port to allow diagnosis and debugging of the Minimus using a serial terminal emulator (see [section](#)).

Note: This facility should rarely be required. It is primarily intended for use by the Güralp Support Team to help diagnose any problems with the Minimus that may be experienced by the user.

A serial-to-USB converter (not supplied) may need to be used to connect to PCs or laptops that don't have a nine-pin serial connector. Please see [section](#) for full pin-out details.

3.3 Güralp Discovery software

Güralp Discovery is a software application for seismometer configuration and control, state-of-health monitoring, and waveform viewing and acquisition.

Güralp Minimus and Minimus+

Status	Label	System	Name	Firmware Ver	WAN Address	LAN Address	Uptime	Last Contact	Latitude	Longitude
✓	NO LABEL	Fortimus	FMUS-C65A	1.3-16444	89.213.16.113	10.20.0.155	20:50:54	Just Now	51.3607	-1.1634
✓	NO LABEL	Fortimus	FMUS-BB5A	1.3-16444	89.213.16.113	10.20.0.118	7 days 8 Hrs	Just Now	51.3606	-1.1635
✓	Radian Vertica...	Minimus	MIN-2456	1.2-8572	89.213.16.113	10.20.0.227	145 days 18 Hrs	Just Now	51.3610	-1.1638
✓	NO LABEL	Fortimus	FMUS-BF5A	1.3-16444	89.213.16.113	10.20.0.224	13 days 23 Hrs	Just Now	51.3606	-1.1635
✓	NO LABEL	Fortimus	FMUS-545A	1.3-14268	89.213.16.113	10.30.0.18	8 days 20 Hrs	Just Now	51.3611	-1.1642
✓	NO LABEL	Minimus	MIN-002757	2.0-2019	89.213.16.113	10.30.0.127	14 days 1 Hrs	Just Now	-59.9000	87.2170
✓	Radian Rack 2...	Minimus	MIN-2856	1.2-8701	89.213.16.113	10.20.0.86	1 days 16 Hrs	Just Now	51.3611	-1.1638
✓	SUPRT-FMUS	Fortimus	FMUS-8859	2.0-1077	89.213.16.113	10.10.0.19	16 days 0 Hrs	Just Now	51.3606	-1.1630
⚠	NO LABEL	Minimus	MIN-4056	1.2-8707	89.213.16.113	10.20.0.53	20:30:22	2019-08-07T10:40:20	51.3607	-1.1635
✓	3T ref	Minimus	MIN-004058	2.0-402	89.213.16.113	10.30.0.152	4 days 22 Hrs	Just Now	51.3616	-1.1640
✓	Radian Rack 5...	Minimus	MIN-E256	1.2-8706	89.213.16.113	10.20.0.232	2 days 2 Hrs	Just Now	51.3609	-1.1638
✓	Radian Rack 1...	Minimus	MIN-C757	1.2-8700	89.213.16.113	10.20.0.134	4 days 19 Hrs	Just Now	51.3609	-1.1637
✓	SHAKER MK I ...	Minimus	MIN-B157	1.2-8701	89.213.16.113	10.20.0.127	1 days 3 Hrs	Just Now	0.0000	0.0000
✓	Radian Rack 4...	Minimus	MIN-E457	2.0-35	89.213.16.113	10.20.0.137	7 days 18 Hrs	Just Now	51.3609	-1.1638
✓	ENG-TEST	Minimus	MIN-6955	1.2-8700	89.213.16.113	10.30.0.103	45 days 21 Hrs	Just Now	51.3612	-1.1642
✓	BEN	Minimus	MIN-000057	2.0-2670	89.213.16.113	10.30.0.23	1 days 2 Hrs	Just Now	-59.9044	87.7204

Scan Locally Registry

Registered Systems

An important benefit of Discovery is that it allows the user to identify the instruments' I.P. addresses on a LAN or via a cloud-based or organisational registry server without the need for static I.P. addresses at the stations.

Discovery also provides simple, convenient instrument and data management with access to hardware State-of-Health (SoH), data streaming; GNSS location; response and calibration data.

Discovery can download Minimus firmware from the Internet and remotely install it onto any connected Minimus digitisers.

3.4 Güralp GüVü Android and iOS app

For added confidence during deployments in the field, Güralp GüVü, a Bluetooth App, displays waveforms, orientation, temperature and humidity data for instant checking of installation integrity.

Please refer to [section](#) for installation and usage instructions.



4 Getting started

4.1 System set-up

Güralp highly recommends exploring and gaining familiarity with the Minimus inside your lab before installation in an outdoors environment.

A typical set-up for the Minimus connected to an analogue sensor (including an optional digital Radian Post-hole instrument) is shown in the figure below:

Güralp Minimus and Minimus+

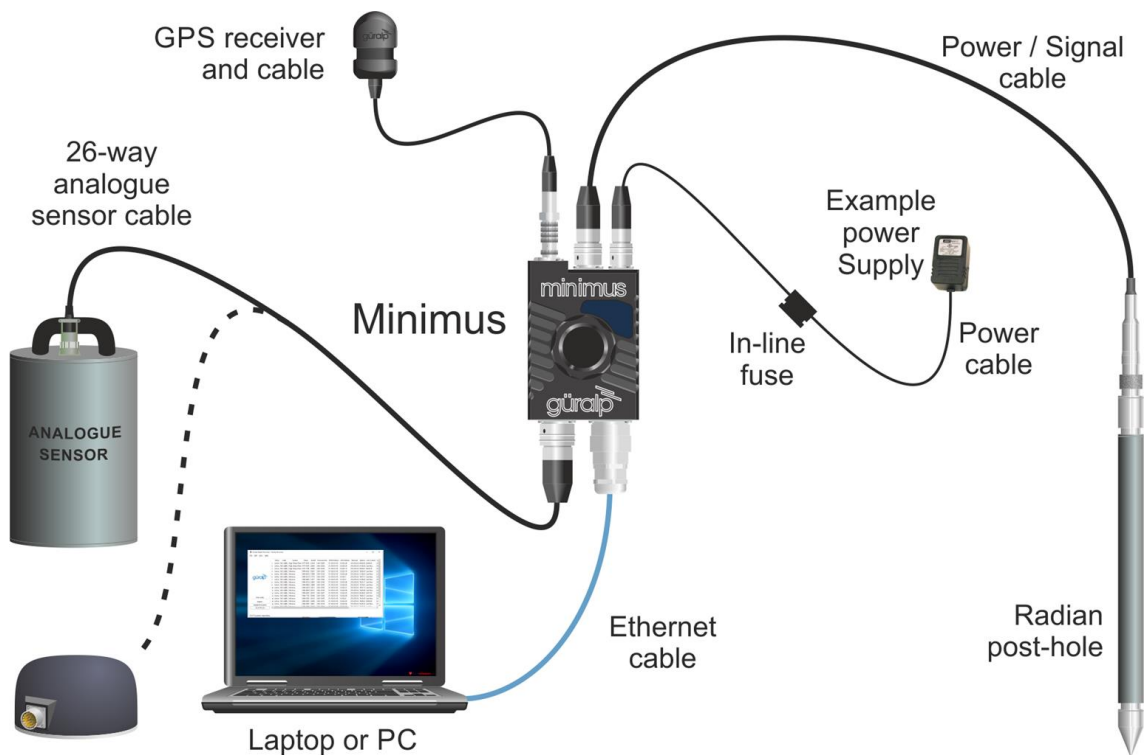

To get started, connect the cables as shown in the figure above and as described in section 3.2 on page **Error! Bookmark not defined.** (and, optionally, Section 4.3 of the Radian manual, MAN-RAD-0001).

Power up the Minimus using a power supply with a DC output of between 10 and 36 Volts. We recommend fitting an in-line 3.5 A anti-surge fuse in the positive power lead to protect the external wiring of the installation. The Minimus will, in turn, provide power to all connected instruments.

Caution: Observe the correct polarity when connecting the power supply. The **red** lead (from pin B) must be connected to the **positive terminal**, typically labelled "+", and the **black** lead (from pin A) must be connected to the **negative terminal**, typically labelled "-". An incorrect connection risks destroying the digitiser, the power supply and any connected instruments.

If the Minimus is directly connected to a laptop or PC using the blue Ethernet cable, make sure that the laptop or PC is configured to obtain an I.P. address automatically. More details on how to correctly configure the connection using APIPA (Automatic Private I.P. Addressing) are in [section](#) .

4.2 Güralp Discovery software installation

To view live waveforms, and to control and configure the Minimus and connected sensors, you will need to use Güralp Discovery software.

Güralp Minimus and Minimus+

Visit www.guralp.com/sw/download-discovery.shtml for links for all available platforms (currently Windows 32-bit and 64-bit, macOS 64-bit and Linux 64-bit).

Download the installer appropriate for your architecture and operating system, run the installer and follow the instructions on screen. (Full details of installation and upgrading are in [section](#).)

Note: Windows users may have to reconfigure the Windows FireWall in order to allow Discovery to communicate properly. Please see [section](#) for full details. Brief instructions are below.

Under Windows, the first time that you start Discovery, Windows may ask you to specify how you wish Discovery to interact with the Windows Firewall. Because Discovery requires network communication in order to function, it is important that you understand the options available.

The following screen is displayed:

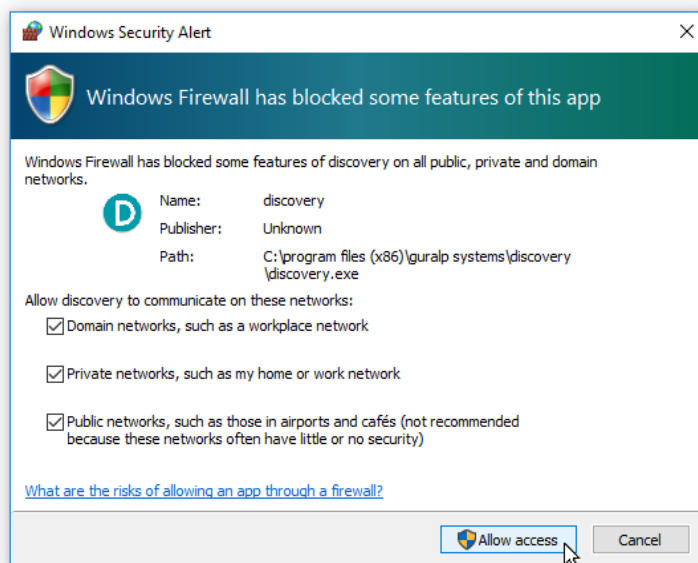

The screen provides three check-boxes which indicate whether Discovery can communicate with networked devices in the “Domain” profile, the “Private” profile or the “Public” profile. (Profiles are also known as “network locations”.)

The “Domain” profile applies to networks where the host system can authenticate to a domain controller. The “Private” profile is a user-assigned profile and is used to designate private or home networks. The default profile is the “Public” profile, which is used to designate public networks such as Wi-Fi hotspots at coffee shops, airports, and other locations.

Güralp Minimus and Minimus+

For a more complete discussion of this topic, please see www.tenforums.com/tutorials/6815-network-location-set-private-public-windows-10-a.html or your Windows documentation.

Once you have specified your firewall preferences, Discovery displays a main window which normally shows a list of both locally and remotely connected instruments. If you close this main window, Discovery will quit.

Discovery will initially “listen” for connected instruments on your local network.

This mode can be refreshed by clicking the **Scan Locally** button or by pressing the

short-cut keys **Ctrl** + **L**. These features are identified below:

Scan the local network for locally-connected instruments and digitisers

Load list of registered systems from a central registry and attempt to contact them

Specify here the I.P address of the central registry (cloud server)

Connected instruments

Status	Label	System	Name	Serial#	Firmware Ver	WAN Address	LAN Address	Uptime	Latitude	Longitude
🟢	TR1207-487	Minimus	MIN-8657	34391	1.1-1022	89.213.16.113	10.30.0.65	7 days 19 Hrs	51.3612	-1.1640
🟢	TR1204-484	Minimus	MIN-8757	34647	1.1-1022	89.213.16.113	10.30.0.67	6 days 17 Hrs	51.3612	-1.1640
🟢	TR1205-485	Minimus	MIN-8857	34903	1.1-1022	89.213.16.113	10.30.0.40	7 days 19 Hrs	0.0000	0.0000
🟢	NO LABEL	Minimus	MIN-9355	37717	1.1-1022	89.213.16.113	10.30.0.77	18:01:29	51.3612	-1.1640
🟢	NO LABEL	Minimus	MIN-A957	43351	1.1-1022	89.213.16.113	10.30.0.131	7 days 19 Hrs	51.3612	-1.1640

You can add instruments to the list by right-clicking in the blank area and selecting "Add device" or choosing this option from the Edit menu:

Local Systems

Status	Label	System	Name	Firmware Ver	LAN Address	Uptime	Last Contact	Latitude	Longitude	Altitude	Timing quality
🟢	SPRT-FMUS	Fortimus	FMUS-DE5B	2.0-7544	10.10.0.25	01:36:27	Just Now	51.3605	-1.1632	133.70	0
🟢	NO LABEL	Minimus	MIN-AF55	1.2-8707	10.10.0.6	6 days 1 Hrs	Just Now	0.0000	0.0000	0.00	0
🟢	DEMO 83	Minimus	MIN-C456	2.0-7544	10.10.0.17	01:19:32	Just Now	51.3606	-1.1633	130.70	0
🟢	SPRT-MIN	Minimus	MIN-C555	2.0-7545	10.10.0.10	00:55:04	Just Now	51.3606	-1.1633	103.10	100

Context Menu:

- Data Viewer
- CAP Receiver
- Add Device**
- miniSEED Extractor
- Power board control
- Sonardyne Debugger

Güralp Minimus and Minimus+

The following dialogue is displayed:

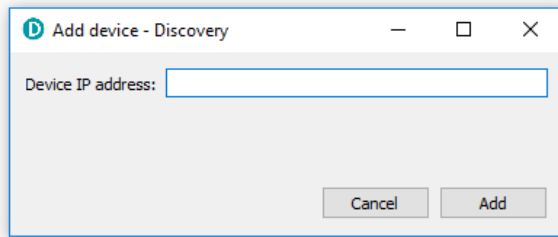

Enter the I.P. address of the Minimus (or other device, such as Güralp Affinity) to be added and click the **Add** button. The newly added device will appear in the device list.

Note: The newly added device will be removed from the list and not automatically re-added if a local network scan is performed.

You can choose which information is shown for each device in the main window. You can select which columns to display – and hide unwanted ones – by clicking on "Show" from the "View" menu.

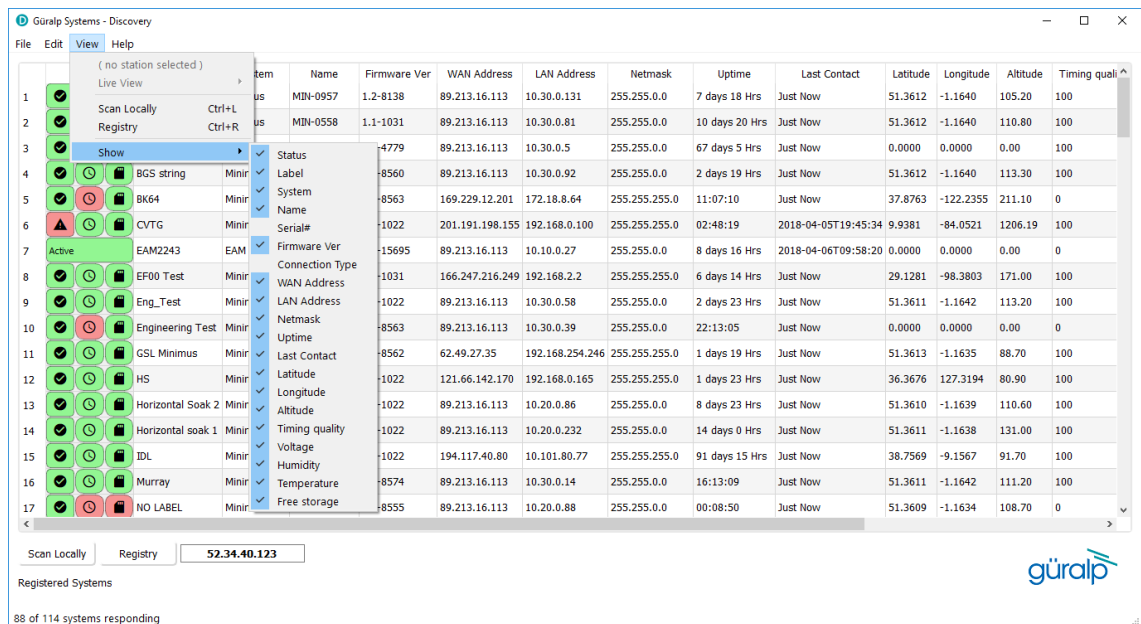

The "Status" column is composed of three icons that represent the Minimus connectivity status (whether Minimus is reachable/active or not), timing status (GNSS or PTP) and storage status (primary/secondary) respectively.

Güralp Minimus
and Minimus+

Hovering the mouse over any of these three icons will display tool-tips giving a brief description of the status including, for the timing indicator, details of which timing subsystems are operating:

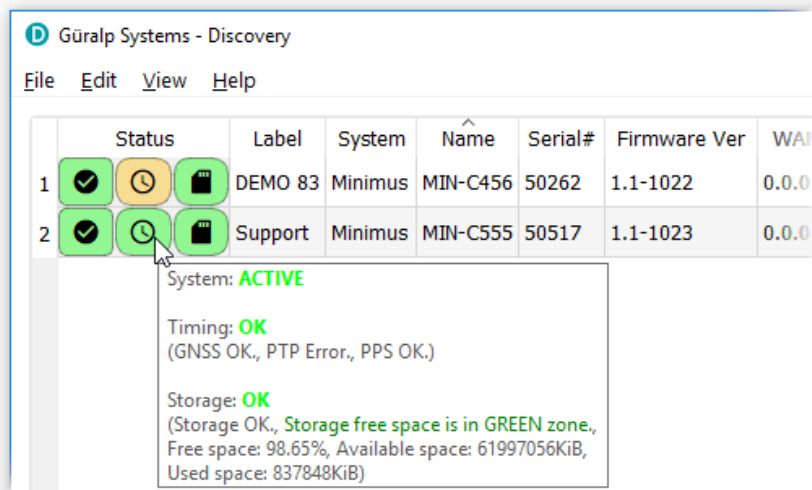

Within Discovery, internal and connected sensors are referred to as follows:

Sensor	Minimus designation	Minimus+ designation
All internal sensors	Sensor 0	Sensor 0
First analogue sensor	Sensor 0	Sensor 0
Second analogue sensor	<i>n/a</i>	Sensor 1
First Radian (digital sensor)	Sensor 1	Sensor 2
Second Radian (digital sensor)	Sensor 2	Sensor 3
Third Radian (digital sensor)	Sensor 3	Sensor 4
...
Last Radian (digital sensor)	Sensor 8	Sensor 8

4.3 Viewing waveforms and system state-of-health

Waveform data recorded by the Minimus' internal sensors and other connected sensors can be viewed using several methods, which are described in the following sections.

4.3.1 Using Discovery's "Live View" window

4.3.1.1 Main features

Discovery offers a versatile live waveform/data viewer. To open the Viewer, in Discovery's main window, select an instrument and, from the View tab in the toolbar, select "Live View".

The menu will then present three options for data streaming:

- GDI and GCF channels
- GDI only
- GCF only

The GCF option uses the Scream! Protocol to stream data in GCF packets of, typically, 250, 500 or 1,000 samples. The GDI protocol streams data sample-by-sample and also allows the sending of each instrument's calibration parameters so that data can be expressed in terms of physical units rather than digitiser counts.

Güralp recommends using the “GDI only” option for waveform viewing.

The main features of – and the key buttons within – the Live View window are shown in the following screen-shot. Basic amplitude and time zoom functions are given in the Window zoom controls panel and streams can be easily added to or removed from the window by using the check-boxes in the left panel.

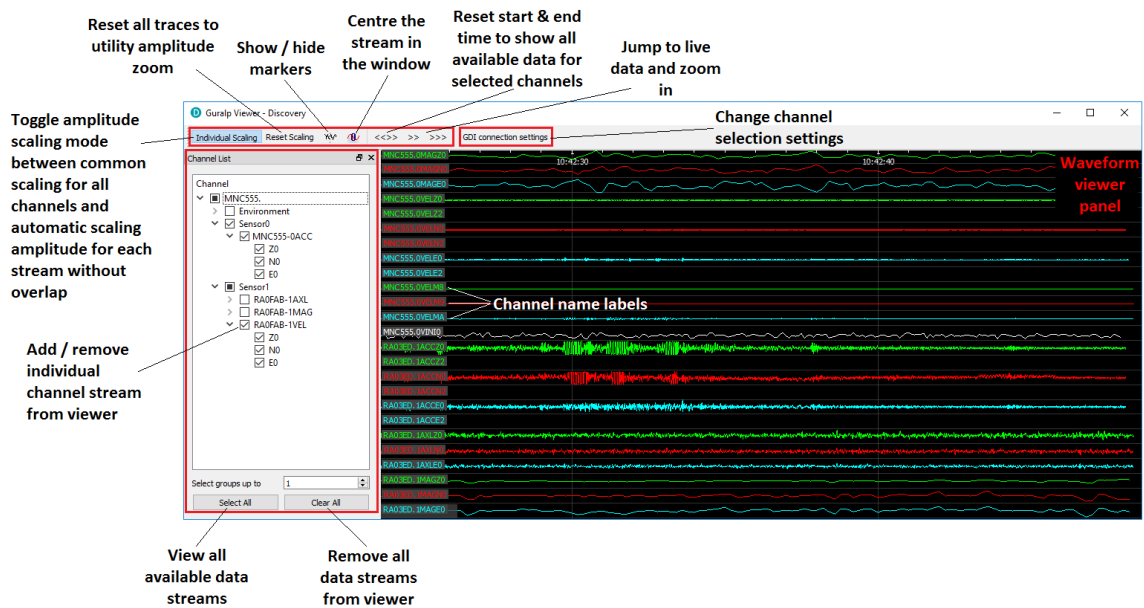

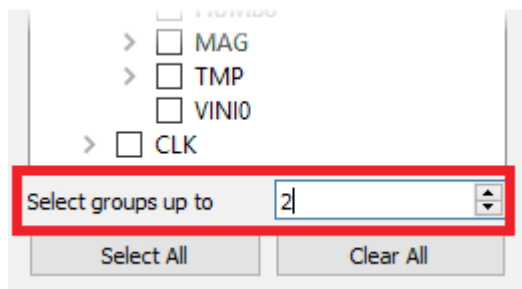

The channels are divided in groups with different hierarchical importance. The most important are the velocity/acceleration channels with higher sample rates: these belong to group 1. The least important belong to group 6, which includes humidity, temperature, clock diagnostics *etc*. When the live view is launched, only the channels in group 1 are selected. It is possible to change this setting by selecting a different group number from the “Select group up to” box at the bottom of the channel list.

Güralp Minimus and Minimus+



When only few channels are selected for viewing, the channel name labels also show data statistics, including the maximum, minimum and average amplitudes in physical units.

If too many channels are in view for this information to be visible, you can left-click on a label and the label and trace will then expand to half the height of the screen, revealing these statistics. The other channels will be compressed into the remaining space. Another left-click on the same channel will return the window to normal. Alternatively, a left-click on a different channel will shrink the original one and expand the newly-selected one.

By selecting and dragging the mouse over a window of waveform data, the viewer will display similar statistics for the data within the selected window. When a window of data is selected, use the  key to subtract the ADC offset from the maximum, minimum and average values. Use the  key to calculate the integral of the selected data. By right-clicking on the window, you can perform advanced analysis on the data, including plotting power spectral density graphs (PSDs), spectrograms and discrete Fourier transforms (DFTs), as shown below:

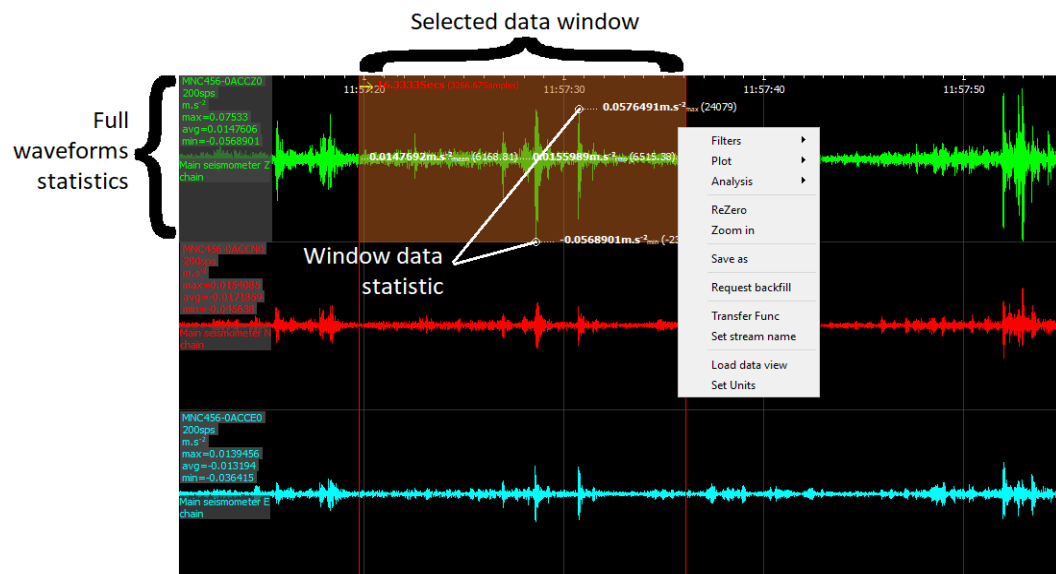











Güralp Minimus and Minimus+

4.3.1.2 Window control short-cuts

You can change the display of the waveforms with based on a combination of key-strokes and mouse-wheel scrolling (or track- / touch-pad scrolling on a laptop).

These commands are shown in the table below:

Command	Window control
<i>Amplitude control</i>	
	Increase/decrease amplitude of all traces
 + hover cursor over channel label	Increase/decrease amplitude of individual trace
 +  + hover cursor over channel label	Shift individual trace offset up/down
<i>Time control</i>	
 + 	Pan time-scale right/left
 + 	Zoom time-scale in/out
<i>Trace focus</i>	
 on trace label	Focus on individual trace
<i>Trace selection</i>	
 + hover cursor over on individual trace / trace label	Remove / de-select trace from Viewer window
<i>Details control</i>	
 + hover cursor over on individual trace / trace label	Reset the maximum and minimum values to the average value of the selected data

4.3.1.3 GDI connection settings

The GDI protocol allows a receiver, such as Discovery, to select which channels to receive by use of a “channel subscription list”. This feature can be useful in cases where the connection between Minimus and Discovery has limited bandwidth. To subscribe to specific channels, right-click on a digitiser in Discovery’s main window and select “GDI Configuration” from the context menu.

Güralp Minimus
and Minimus+

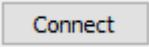

The resulting window has two very similar tabs. The “Subscription configuration” tab refers to channels selected for transmission and the “Storage configuration” tab affects which channels are selected for recording.

Click on the  button to connect to the Minimus GDI server.

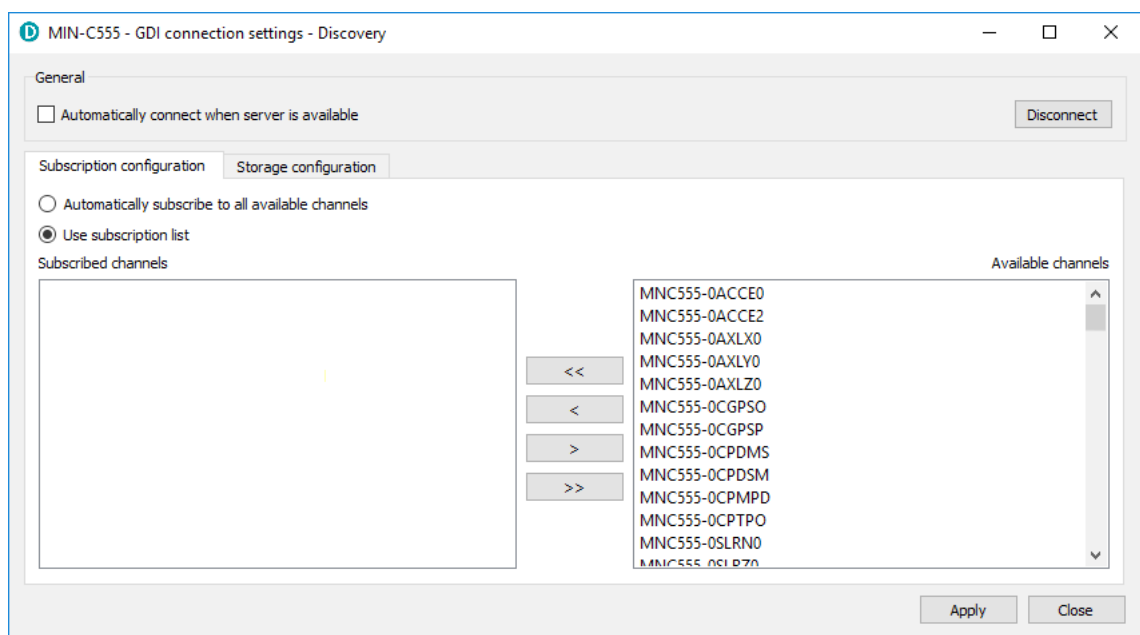
By default, Discovery subscribes to all channels. To alter this behaviour, change the radio-button from “Automatically subscribe to all available channels” to “Use subscription list”. In subscription list mode, the channels in the list on the left-hand side are those to which Discovery subscribes. All available channels are listed on the right-hand side.

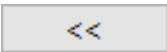

Channels can be moved between lists – *i.e.* switched between being subscribed and being unsubscribed – by using the arrow buttons on the middle:

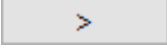
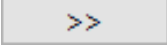
	Subscribe to all channels shown in the Available channels list
	Subscribe to all selected channels in the Available channels list
	Unsubscribe from all selected channels in the Subscribed channels list
	Unsubscribe from all channels in the Subscribed channels list

4.3.1.4 Backfill from microSD card

Gaps in the waveforms due to network disconnections can be backfilled by requesting missing data to the local storage.

Güralp Minimus and Minimus+

In the Discovery GDI “Live View”, highlight the portion of data including the gap, right-click and select “Request backfill”.

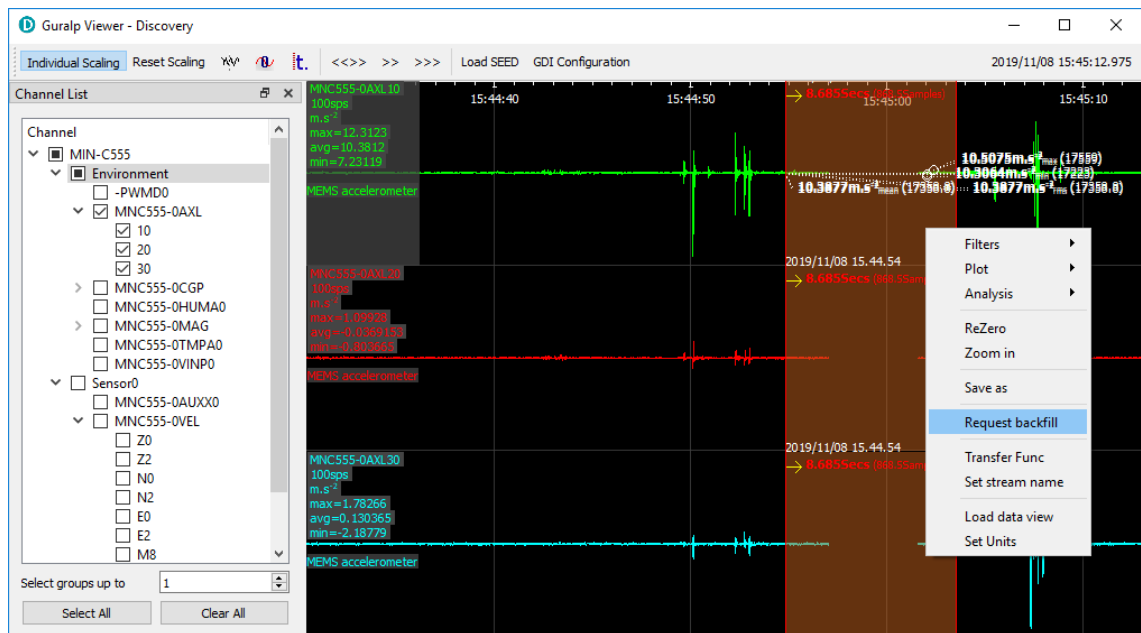

The gaps are backfilled automatically for all the streams selected, if the requested data is available in the microSD card.

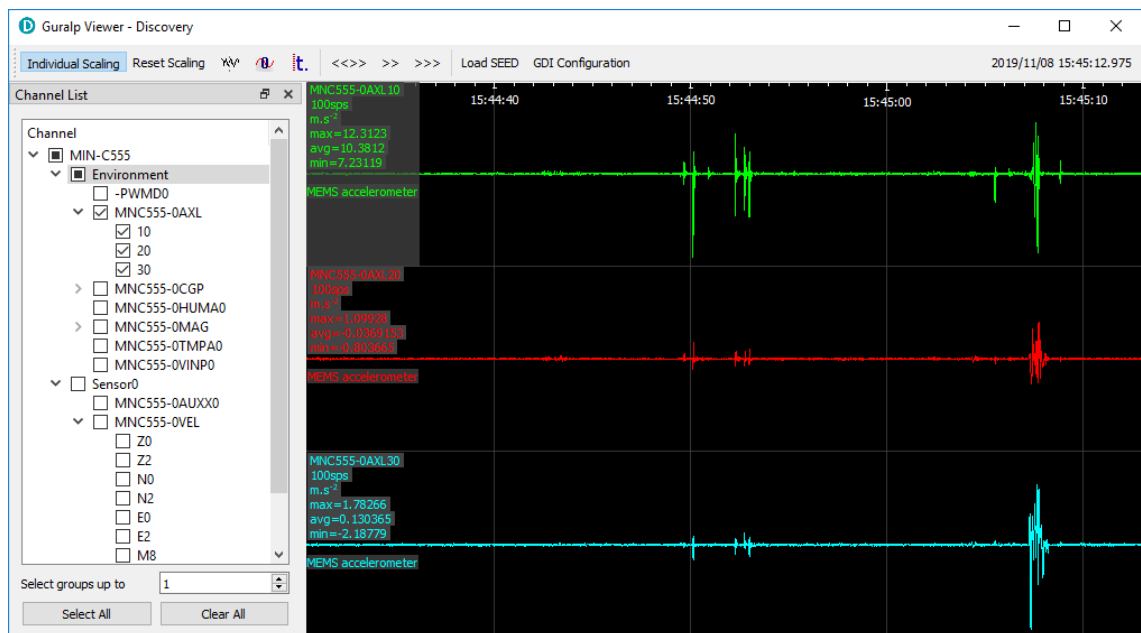

4.3.2 Using Scream!

Data from the Minimus and attached sensors can also be viewed and analysed using Güralp's Scream! Software.

For full usage information on Scream!, please refer to the on-line Güralp manual **MAN-SWA-0001**.

Güralp Minimus
and Minimus+

In Scream!'s Network Control window, add a UDP or TCP Server using the address reported under "LAN Address" in Discovery's main window.

	Status	Label	System	Name	Serial#	Firmware Ver	WAN Address	LAN Address	Uptime	Latitude	Longitude
1		Support	Minimus	MIN-C555	50517	1.1-1022	0.0.0.0	10.10.0.13	00:15:10	51.3607	-1.1630

Right-click on the newly-added server and select `GCFSEND:B` (or `Connect`) from the context menu. This sends a command to the Minimus to start data transmission. Once the `GCFSEND:B` (or `Connect`) command has been issued, the instruments and their associated streams should begin to appear in Scream!'s main window.

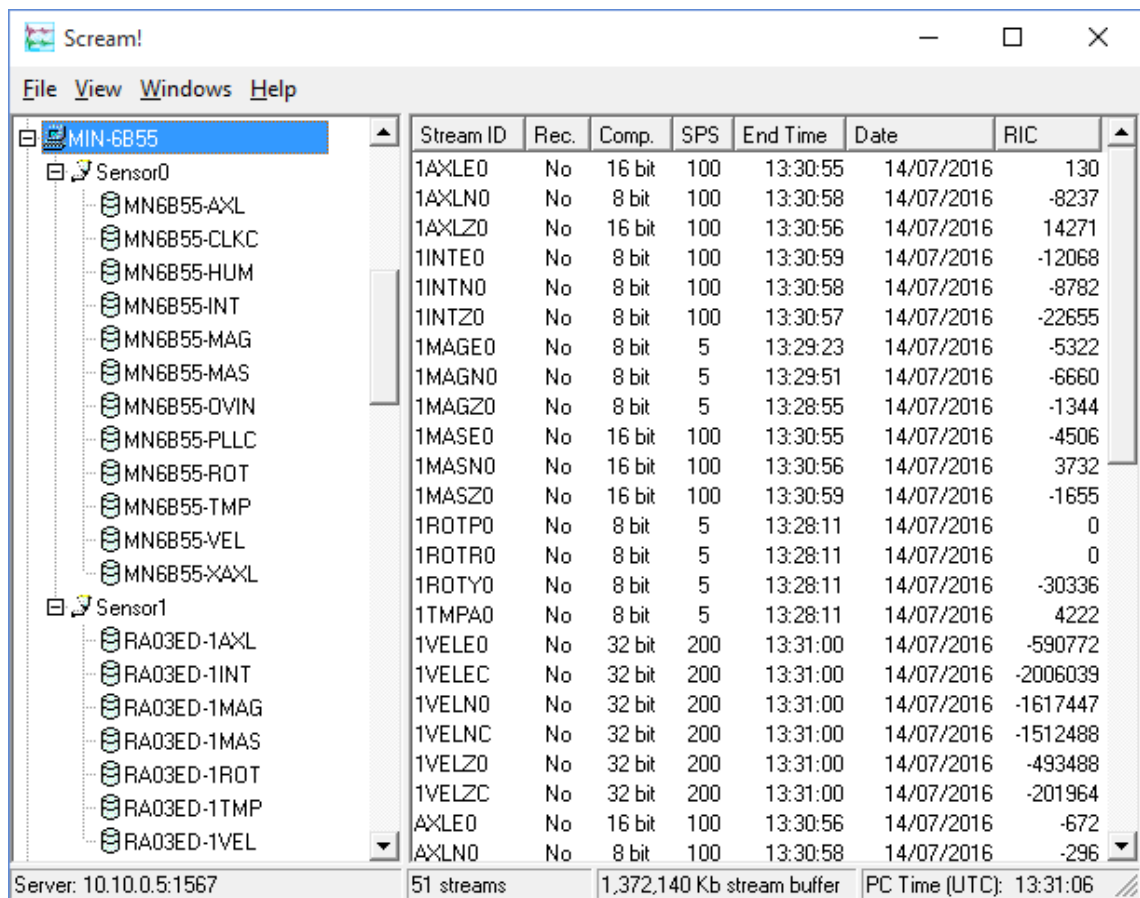

To configure the Minimus, double-click on its entry to open its web page.

Note: If stream recording is enabled, make sure that the file-name format in Scream! (on the Files tab of the `File`→`Setup` dialogue) is set to

`YYYY\YYYYMM\YYYYMMDD\I_A_YYYYMMDD_HHNN`

in order to prevent file names conflicting. More information can be found in Scream! manual **MAN-SWA-0001** available on the Güralp website.

5 System configuration

System configuration, control and configuration tools are available by selecting an instrument in Discovery, right-clicking its entry and selecting “View Web Page”. Alternatively, the web interface can be viewed by navigating to the LAN or WAN address of the instrument from any common web browser.

Note: Some changes in the settings require a system reboot to be applied. This is notified on the top right of the Minimus web page with the message *Reboot Required*. It is suggested to perform all the modifications and reboot the Minimus when the configuration is completed clicking on any of the  buttons.

5.1 Web Page login

The web interface can be protected by username and password. There are two levels of access to the web page: normal user and administrator.

If the login is required, the web interface will initially show a status display only.

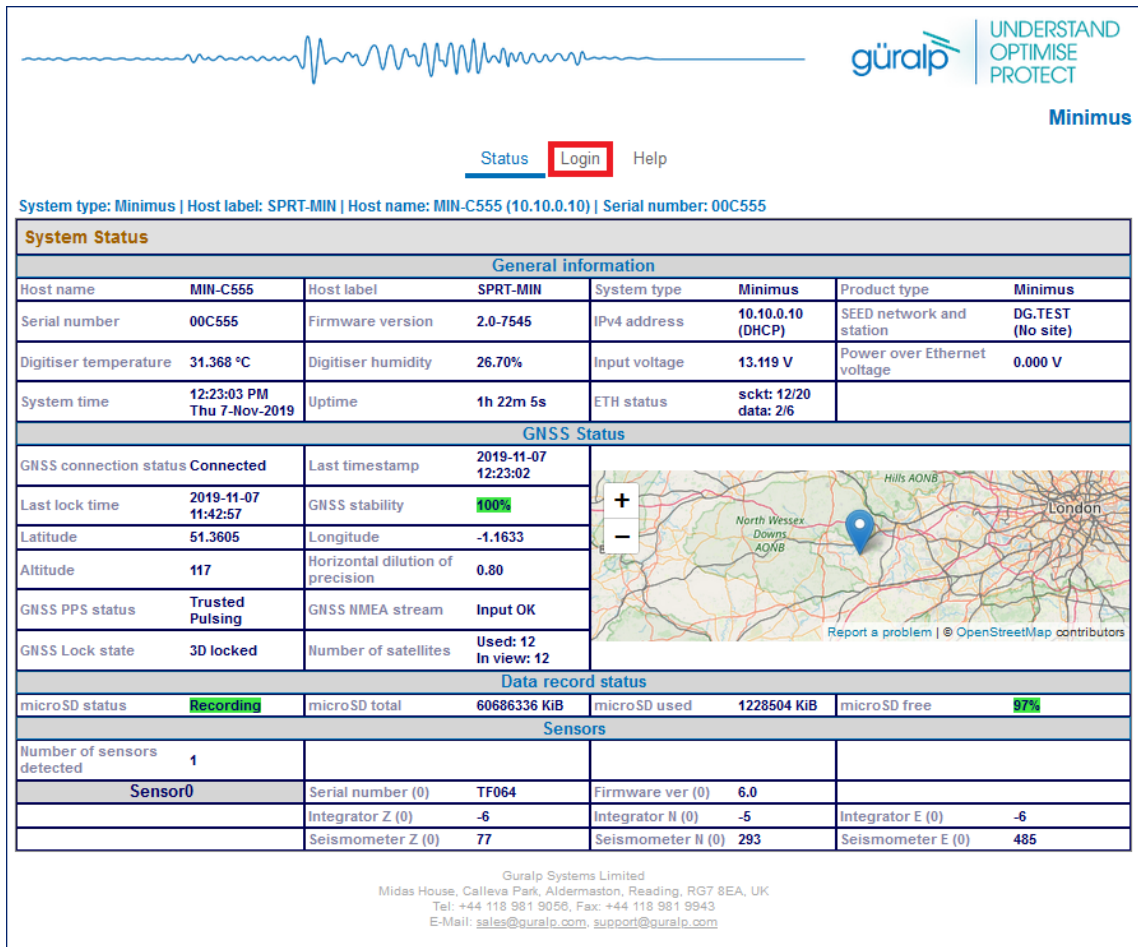

 UNDERSTAND
OPTIMISE
PROTECT
Minimus

[Status](#) **Login** [Help](#)

System type: Minimus | Host label: SPRT-MIN | Host name: MIN-C555 (10.10.0.10) | Serial number: 00C555

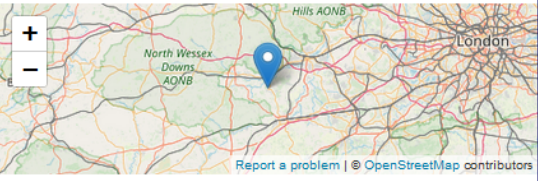
System Status							
General information							
Host name	MIN-C555	Host label	SPRT-MIN	System type	Minimus	Product type	Minimus
Serial number	00C555	Firmware version	2.0-7545	IPv4 address	10.10.0.10 (DHCP)	SEED network and station	DG.TEST (No site)
Digitiser temperature	31.368 °C	Digitiser humidity	26.70%	Input voltage	13.119 V	Power over Ethernet voltage	0.000 V
System time	12:23:03 PM Thu 7-Nov-2019	Uptime	1h 22m 5s	ETH status	sckt: 12/20 data: 2/6		
GNSS Status							
GNSS connection status	Connected	Last timestamp	2019-11-07 12:23:02				
Last lock time	2019-11-07 11:42:57	GNSS stability	100%				
Latitude	51.3605	Longitude	-1.1633				
Altitude	117	Horizontal dilution of precision	0.80				
GNSS PPS status	Trusted Pulsing	GNSS NMEA stream	Input OK				
GNSS Lock state	3D locked	Number of satellites	Used: 12 In view: 12				
Data record status							
microSD status	Recording	microSD total	60686336 KiB	microSD used	1228504 KiB	microSD free	97%
Sensors							
Number of sensors detected	1						
	Sensor0	Serial number (0)	TF064	Firmware ver (0)	6.0		
		Integrator Z (0)	-6	Integrator N (0)	-5	Integrator E (0)	-6
		Seismometer Z (0)	77	Seismometer N (0)	293	Seismometer E (0)	485

Güralp Systems Limited
 Midas House, Calleva Park, Aldermaston, Reading, RG7 8EA, UK
 Tel: +44 118 981 9056, Fax: +44 118 981 9943
 E-Mail: sales@guralp.com, support@guralp.com

Güralp Minimus and Minimus+

Clicking on “Login” opens allows to type in the user-name and password to access the content of the web page.



Logging in with normal user account unlocks only basics configuration and control features in order to prevent any advanced settings to be modified. The default user-name for normal user login is user and password of user.

Logging in with the administrator account unlocks all the configuration and control features available in the Minimus web page. The default user-name for administrator user login is admin and password of admin.

Once logged in, the “Web Login” drop-down menu in the Network tab allows to disable the request of login every time the web page is accessed. The user-name and password for both normal user and administrator login are configurable in the “Network” tab.

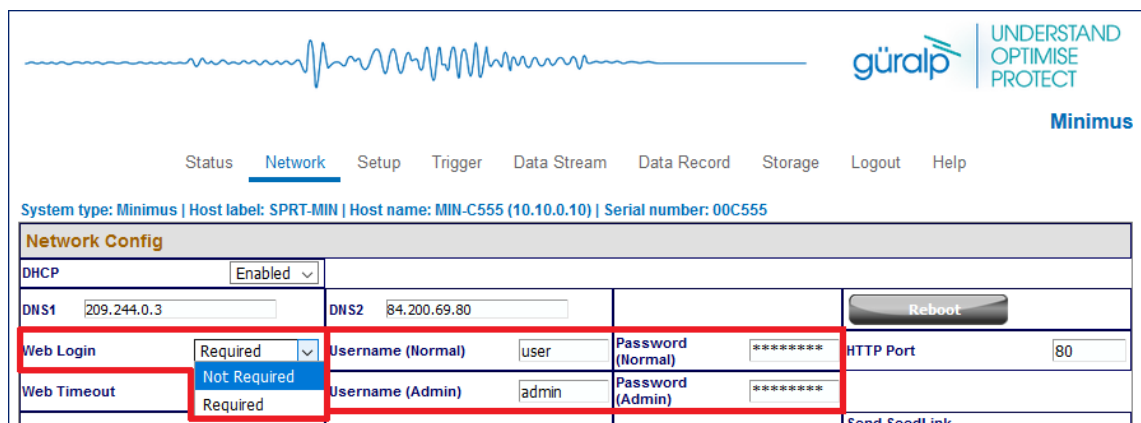

5.2 System status

The “Status” tab of the web browser interface provides state-of-health information about the Minimus and connected instruments. These parameters are described as follows:

- **Host name:** the serial number and model of the device;
- **Host label:** the customisable name of the Minimus system;
- **System type:** the name of the connected digitiser, *e.g.* “Minimus”;

Güralp Minimus and Minimus+

- **Product type:** the type of the connected digitiser, *e.g.* “Minimus”;
- **Serial number:** the serial number of the Minimus;
- **Firmware version:** the DIG firmware version running on the Minimus;
- **IPv4 address:** the static or Dynamic LAN I.P. address of the Minimus;
- **SEED network and station:** Network and Station SEED codes of the Minimus;
- **Digitiser temperature, humidity, Input voltage and PoE voltage** (⚠ Minimus+ only): the internal temperature and humidity of the Minimus; input voltage supplied and optional PoE voltage (⚠ Minimus+ only) supplied to the Minimus;
- **System time:** the current internal system date and time;
- **Uptime:** the time the Minimus has been running since the last reboot;
- **ETH status:** the number of total active TCP connection in use and connection used for data transmission;
- **GNSS status, last GNSS time-stamp, last GNSS lock time** since significant timing drift or re-boot, **GNSS stability** of the lock, **horizontal dilution of precision** (based on satellite coverage), **GNSS PPS status, GNSS NMEA stream, GNSS lock state** (2-D or 3-D), **number of satellites** used and in view;
- **Latitude, longitude and altitude** of the system, as provided by the GNSS receiver;
- **PTP state, last PTP time-stamp, last PTP lock time** since significant timing drift or re-boot, **PTP stability** in time accuracy, **master IPv4 address** (I.P. address of the PTP master), **master clock class and accuracy, master time source, network path delay, network jitter estimate** (quality indicator in ns), **network outliers**;
- MicroSD card **recording status, total storage capacity, used storage space and available storage space**;
- **Number of instruments** connected; and
- **Real-time sensor values** from the connected instruments.

5.3 Station meta-data

Discovery provides a number of flexible station meta-data inputs. These are accessible from the “Setup” tab of the instrument’s web page.

“**Label**” and “**Site Name**” are used in Discovery only and appears in the list of instruments in the main window.

“Station Name”, “Network Code” are all standard meta-data header values used by the miniSEED file format, which will be included in locally-stored miniSEED files (see section 8 on page **Error! Bookmark not defined.**).

5.4 Network configuration

5.4.1 I.P. address and gateway

By default, the Minimus uses DHCP (Dynamic Host Configuration Protocol) to acquire its network configuration but static addressing can be used if required.

To configure static addressing, visit the “Network” tab of the instrument’s web page and, under “DHCP”, change the mode from “Enabled” to “Disabled” in the drop-down menu. In this mode, it is possible to specify the I.P. address, the Netmask and the address of the Gateway (default router), as shown:

The screenshot shows the Minimus web interface with the 'Network' tab selected. The system information at the top indicates: System type: Minimus | Host label: SPRT-MIN | Host name: MIN-C555 (10.10.0.10) | Serial number: 00C555. The 'Network Config' section is highlighted with a red border and contains the following fields:

DHCP	Disabled	Static IP addr	10.10.0.10	Net Mask	255.255.255.0	Gateway	10.10.255.1
DNS1	209.244.0.3	DNS2	84.200.69.80			Reboot	
Web Login	Required	Username (Normal)	user	Password (Normal)	*****	HTTP Port	80

Before any changes made here will take effect, the Minimus must be re-booted. To do this, click the  button on the “Data Record” tab.

Note: By default, the static I.P. address assigned to each Minimus is unique and derived from the specific serial number of the device. These addresses are in the default network for link-local (APIPA) addresses: $169.254.0.0/16$ (in CIDR notation).

The first two octets of the address, therefore, are always 169.254 . The third octet is the equal to the last two characters of the serial number interpreted as a hexadecimal number and then converted into base 10. The fourth octet is the equal to the next-to-last two digits of the serial number, also converted from hexadecimal into base 10.

For example, if the serial number of the Minimus is MIN-C555, the preassigned Static I.P. address will be $169.254.85.197$, where

- MIN-C555 \Rightarrow "55" \Rightarrow $(55)_{16} = (85)_{10} \Rightarrow 85$ and
- MIN-C555 \Rightarrow "C5" \Rightarrow $(C5)_{16} = (197)_{10} \Rightarrow 197$

Güralp Minimus and Minimus+

Network settings are also available in Discovery by right-clicking on the Minimus' entry in Discovery's main window and selecting "Edit Network Address".

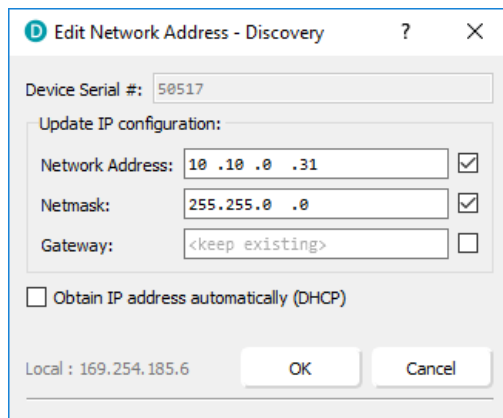

5.4.2 NTP (Network Timing Protocol) configuration

Note: Network Timing Protocol (NTP) is only used for setting the system's internal clock at boot-up, it is *not used for sample timing*. See [section](#) for details about synchronising the sample clock.

However: if neither GNSS nor PTP are available but NTP is locked and the sample clock's time is more than five seconds different from NTP's time, the sample clock will be adjusted (in a step-change) to NTP time.

By default, the NTP server option (located under the "Setup" tab of the instrument's web page) is set to "Pool" which uses the virtual server `pool.pool.ntp.org`. This accesses a dynamic collection of networked computers that voluntarily provide moderately accurate time via the NTP to clients worldwide.

Alternatively, it is possible to specify the I.P. address of your preferred NTP server. To do this, select the "Static" option from the "NTP server" drop-down menu, which activates the "NTP IP Addr" setting, and enter the I.P. address of your NTP server here.

Network Timing			
PTP Mode	Disabled	PTP Offset Correction	0 nanoseconds
		PTP Transmission Mode	Multicast
NTP Server	Pool		
Registry	Disabled		
Registry Update	Even	Group ID	SOF
		Registry Address	52.34.40.123

5.5 GDI push (auto-connection)

A Minimus normally acts as a GDI server, where a client initiates a connection in order to pull data from it. This is the mechanism used when the GDI viewer in Discovery is launched.

Güralp Minimus and Minimus+

The "GDI auto-connection" feature enables the Minimus to establish *outgoing* network connections in order to *push* data to one or more remote clients, such as Platinum systems or an Earthworm system running the `gdi2ew` plug-in.

To configure an auto-connection, type either the I.P. address or the host-name of the target client, a colon (':') and the port number (*e.g.* `192.0.2.91:1566` or `affinity10.example.com:1566`), into any of the connection fields in the "Network" tab of the web page.

GDI auto-connection settings			
Connection	<input type="text"/>	Connection	<input type="text"/>
Connection	<input type="text"/>	Connection	<input type="text"/>

When auto-connection from a Minimus to a host is configured, the Minimus will attempt to open a connection to the host. If it fails, it will re-try every 60 seconds. A suitably configured host will accept the connection and the Minimus will then negotiate a link and start streaming data.

If the connection drops, the Minimus will attempt every 60 seconds to reconnect.

Note: The default port number for a GDI-link receiver is 1566. Push servers will normally connect to this port. The default port number for a GDI-link transmitter is 1565. Receivers wishing to pull data will normally connect to this port. See [section](#) for a list of the network ports used by the Minimus.

5.6 QSCD

The Minimus can push data in QSCD format (**Q**uick **S**eismic **C**haracteristic **D**ata) to one or more clients, using outgoing network connections.

To configure a connection, locate the QSCD section of the Network tab of the web page, as shown below. Type either the I.P. address or the host-name of the target client into any of the "Server" fields. This will push data using UDP port 9000, which is the default. If you wish to use a different port number, add a colon (':') and the port number to the end of the specification. For example, `192.0.2.91:9876` or `qscd.server.com:9876`.

QSCD			
QSCD code sensor	Sensor 0 ▾	QSCD code	QSCD0
Connection	<input type="text"/>	Connection	<input type="text"/>
Connection	<input type="text"/>	Connection	<input type="text"/>

The Minimus does not automatically send all data when using the QSCD protocol. Channels to be transmitted must be selected (in Z/N/E triplets) and each channel passed through a QSCD transform. See [section](#) for details on how to configure this transform.

Use the "QSCD code sensor" drop-down menu to select the sensor and assign the desired QSCD code.

5.7 Data storage

The main panel of the "Data Record" tab in the web interface is shown here:

This page allows to configure the recording channels for each of the connected instruments and sensors internal to the Minimus.



The names and contents of each channel are described in [section](#)

Note: When changing a setting in the Minimus web page, ensure that you wait until the page refreshes before changing another setting. This allows time for the previous change to take effect.

The drop-down box at the top-left of the page named "Display Streams" filters out visible channels among All, Enabled and Disabled. The option "Apply configuration for tap groups" automatically apply the same configuration to three streams that belong to the same tap, e.g. S0SeisZA, S0SeisNA, S0SeisEA. The drop-down box at the top-right of the page named "Display On Page" allows to move from different instruments, e.g. Sensor 1.

The page is divided in four columns:

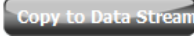
Güralp Minimus and Minimus+

- in the left-most column, drop-down boxes are available for each channel to either select a sample rate or to exclude the channel from streaming (by selecting the “Disabled” option). All streaming can be stopped by clicking the  button. The same configuration can be applied to real-time transmission channels by clicking the  button. The default channel configuration can be applied by clicking the  button.
- in second column from the left, drop-down boxes are available for each channel to enable/disable transforms and, once transform is enabled, to select the transform to apply .
- in third column from left, Location and Channel SEED codes can be configured. Cells are greyed out by default (default values applied) and they can be *edited by clicking on the check-box;*
- in most-right column contains links to the RESP files associated to each of the seismic channels

Upon changing the sample rate, enabling a transform or changing Location and Channels codes, the Minimus will need to be restarted for the changes to come into effect; this can be done by pressing the  button.

During the reboot, the LEDs will flash, displaying the starting-up sequence (see [Section](#)) and the instrument web page will display the following screen.

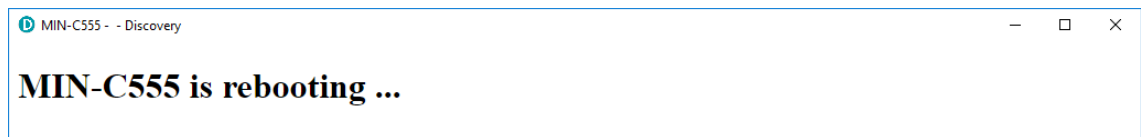

Once the Minimus has successfully restarted, the full web browser display and controls will be available for use again.

5.8 Storage

5.8.1 Recording status

MicroSD cards need to be specifically formatted to operate with the Minimus. The cards shipped with the Minimus and with Radian systems are supplied pre-formatted.

Data are stored on the microSD cards in miniSEED format. Each channel is saved as a series of 128 MiB files. Instrument and station meta-data (*e.g.* instrument response, coordinates, compression type etc.) are stored in "Dataless SEED" format.

The MicroSD card and data recording status can be monitored in the upper panel of the “Storage” tab.

Güralp Minimus and Minimus+



The left-hand column provides details of the external (primary, removable) microSD card and the right-hand column shows the status of the internal (backup, fixed) card.

SD Cards status			
External microSD card present	PRESENT	Number of 128-MiB miniSEED files	452
External microSD card usable	USABLE	Internal microSD card usable	USABLE
External microSD card init count	1	Internal microSD card init count	1
External microSD card is primary microSD card	PRIMARY	Internal microSD card is primary microSD card	BACKUP
Primary microSD card is recording samples	RECORDING	Backup microSD card is recording samples	RECORDING

Sections of this panel indicate the status of the following:

- Whether a card is inserted;
- Whether an inserted card is usable (*i.e.* correctly formatted); and
- Whether the card is recording data.

Note: If the recording status of the cards is marked **NOT RECORDING**,

clicking on  or  may solve the issue. Note that the quick format simply moves the write-pointer to the beginning of the recording space, hence overwriting any existing data. The full format, in contrast, erases all the existing data (and can take several hours).

5.8.2 MicroSD card re-formatting

The card re-formatting process fills the card with 128 MiB files containing zeros. Each file is given a temporary, place-holder name. When data are written, these files are renamed and then over-written with data.

There are two methods for card reformatting: “Quick format” and “Full format”. The quick format mode should be used for pre-deployment tests (*e.g.* stomp/huddle tests) to ensure that the instruments are operating properly. This mode simply marks the existing files as empty without deleting their contents. Full formatting should be used prior to a long-term deployment to ensure that all headers are included and files are fully clean before writing.

The formatting process formats both fixed and removable cards, sequentially.

Note: A series of tests separated only by quick formats can leave some files with residual data in them. This is not normally a problem because a deployment will typically create data-sets longer than any test, over-writing any data remaining from the tests. The miniSEED extractor utility described in section 5.9.3.1 on page 60 can be used to remove the residual data if they cause any problems.

Güralp Minimus and Minimus+

5.8.2.1 Quick format

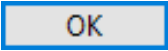
Ensure that the external microSD card is correctly inserted. Click the  button in the “Storage” tab: a dialogue box will appear to confirm the formatting operation – click on  button to continue.

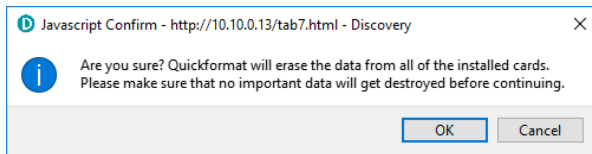

The instrument web page will refresh and return to the “Status” tab. The reformatting operation is now complete.

5.8.2.2 Full format

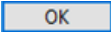
Ensure the external microSD card is correctly inserted. Click the  button in the “Storage” tab and a dialogue box will appear to confirm the formatting operation – click on  button to continue.

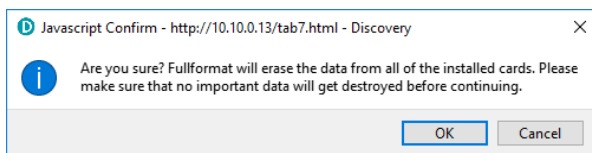



The process takes several hours: check the status countdown indicators on the top-right of “Storage” tab.



Caution: Do not remove or insert the external microSD card while formatting is taking place.

5.8.3 MicroSD card data flushing and unmounting

The  button flushes data still in the buffer into the microSD card storage. Perform a flushing before downloading data from the [Storage tab](#) or [event table](#)

The  button flushes the data from the buffers into the microSD cards and interrupts the recording. The recording restarts if a new card is inserted in the slot or if a quick-format (or full-format) is performed.

5.8.4 Downloading recorded data

The “Storage” tab of the web browser interface displays the miniSEED files stored on the microSD card:

The screenshot displays the Minimus web interface. At the top, there is a logo for 'güralp' with the tagline 'UNDERSTAND OPTIMISE PROTECT' and the product name 'Minimus'. Below the logo is a navigation menu with options: Status, Network, Setup, Trigger, Data Stream, Data Record, **Storage**, Logout, and Help. The system information bar shows: System type: Minimus | Host label: SPRT-MIN | Host name: MIN-C555 (10.10.0.10) | Serial number: 00C555.

The main content area is divided into several sections:

- SD Card control:** Contains four buttons: 'Flush data', 'Unmount Cards', 'Quickformat Cards', and 'Fullformat Cards'. Below these buttons, it indicates 'Formatting status: idle'.
- SD Cards status:** A table showing the status of external and internal microSD cards.

External microSD card present	PRESENT	Number of 128-MiB miniSEED files	463
External microSD card usable	USABLE	Internal microSD card usable	USABLE
External microSD card init count	1	Internal microSD card init count	1
External microSD card is primary microSD card	PRIMARY	Internal microSD card is primary microSD card	BACKUP
Primary microSD card is recording samples	RECORDING	Backup microSD card is recording samples	RECORDING
- Channel data download by time selection:** A form with fields for 'Channel' (set to 'DG.TEST.00.HDF'), 'From' (dd/mm/yyyy), 'To' (dd/mm/yyyy), and a 'Download' button.
- SD Card files:** A table listing files on the SD card.

Filename	Size (bytes)	Last data timestamp
00C555_S0AccEA_00100_00000.mseed	76726272	2019-11-07 16:38:35.110000000
00C555_S0SeisEA_00200_00001.mseed	102752256	2019-11-07 16:35:58.270000000
00C555_S0SeisNA_00200_00002.mseed	102764544	2019-11-07 16:40:54.145000000
00C555_S0SeisZA_00200_00003.mseed	115785728	2019-11-07 16:40:58.610000000
00C555_S0SeisXA_00200_00004.mseed	95154176	2019-11-07 16:36:31.360000000
00C555_S0AccNA_00100_00005.mseed	68460544	2019-11-07 16:37:06.540000000
00C555_S0AccZA_00100_00006.mseed	77713408	2019-11-07 16:37:21.240000000
00C555_S0IntE_00100_00007.mseed	47247360	2019-11-07 16:36:38.200000000
00C555_S0IntN_00100_00008.mseed	47206400	2019-11-07 16:36:38.200000000
00C555_S0IntZ_00100_00009.mseed	47185920	2019-11-07 16:36:38.200000000
status.log	3594107	2019-11-07 16:32:00.000000000
system.log	233008	2019-11-07 16:28:52.000000000
init.log	232796	2019-11-07 16:28:53.000000000
table_of_events.bin	537600	2019-11-07 16:10:56.000000000
- Auxiliary files:** A table listing auxiliary files.

Filename	Description
DG.dataless	Dataless SEED file
fram.log	FRAM log file
calvals.txt	SCREAM! calibration values
polezero.txt	SCREAM! zeros, poles and gains
calib.txt	Calibration text file

At the bottom of the interface, there is contact information for Güralp Systems Limited: Midas House, Calvea Park, Aldermaston, Reading, RG7 8EA, UK. Tel: +44 118 981 9056, Fax: +44 118 981 9943. E-Mail: sales@guralp.com, support@guralp.com.

Clicking on the file from the list automatically starts a download using your browser's standard mechanism:

Güralp Minimus
and Minimus+

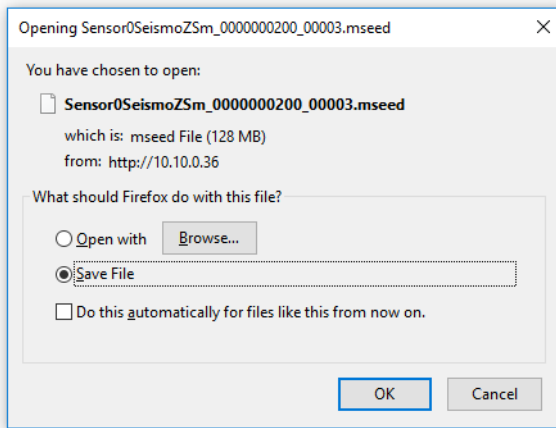

Multiple files can be downloaded simultaneously by ticking the boxes on the left of each link and clicking on **Download selected files** button.

The microSD cards are formatted with empty files which are filled with data as they become available. The file-names are also changed when the files are written to. Until they are written to, they are marked as “hidden” files, so that it is easier to see how many files contain data when looking at the contents of the card.

5.8.5 Downloading data for specific time-intervals

Data for a single stream spanning a specific time-interval can be downloaded from the Storage page of the web interface. To do this, start by selecting the desired stream from the drop-down menu:

Channel data download by time selection						
Channel:	DG.TEST.00.HDF	From:	dd / mm / yyyy -- : --	To:	dd / mm / yyyy -- : --	Download
SD Card files						
<input type="checkbox"/>	DG.TEST.00.HDF					
<input type="checkbox"/>	DG.TEST.00.HHZ					
<input type="checkbox"/>	DG.TEST.00.HHZ	ed	76812288		2019-11-07 16:53:08.470000000	
<input type="checkbox"/>	DG.TEST.00.HHN	ed	102875136		2019-11-07 16:52:23.195000000	
<input type="checkbox"/>	DG.TEST.00.HHN	ed	102842368		2019-11-07 16:51:18.075000000	
<input type="checkbox"/>	DG.TEST.00.HHE	ed	115867648		2019-11-07 16:51:30.735000000	
<input type="checkbox"/>	DG.TEST.00.HHE	ed	95268864		2019-11-07 16:51:50.500000000	
<input type="checkbox"/>	DG.TEST.00.HMZ	ed	68534272		2019-11-07 16:50:45.090000000	
<input type="checkbox"/>	DG.TEST.00.HMZ	ed	77799424		2019-11-07 16:51:14.460000000	
<input type="checkbox"/>	DG.TEST.00.HMN	ed	47296512		2019-11-07 16:49:50.320000000	
<input type="checkbox"/>	DG.TEST.00.HMN	ed	47255552		2019-11-07 16:49:50.320000000	
<input type="checkbox"/>	DG.TEST.00.HMN	ed	47235072		2019-11-07 16:49:50.320000000	
<input type="checkbox"/>	DG.TEST.00.HME	ed	4960256		2019-11-07 16:45:55.700000000	
<input type="checkbox"/>	DG.TEST.00.HME	ed	8941568		2019-11-07 16:47:53.500000000	

... then select the start and end dates and times using the pop-up calendars:

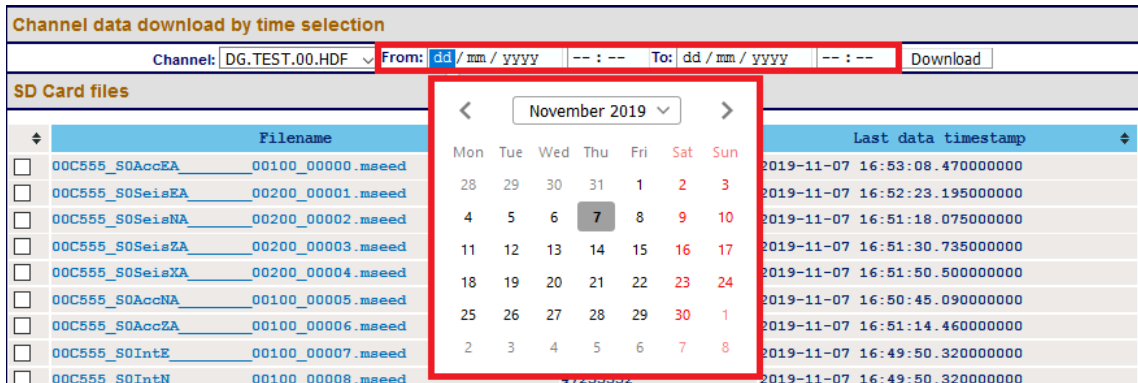

Lastly, click the **Download** download button to initiate a file transfer using your browser's standard mechanism.

Note: The pop-up calendars are not supported by Discovery's built-in browser. The required dates can simply be typed in or the entire operation can be performed in an external web browser.

5.8.6 Bulk data extraction

To view files saved on the external microSD card, remove the card. Insert the card into a microSD card reader (external or in-built) on your PC/laptop. Within a few seconds, the card should appear as a removable disk/drive.

A microSD card formatted for the Minimus contains many "hidden" files. They are created at format time with no contents and then renamed, unhidden and filled with data as required.

When viewing files in Windows Explorer, it may be helpful to configure your system so that "hidden" files are not shown. In Windows 10, this can be done by clearing the "Hidden items" check-box within the ribbon of Windows Explorer.

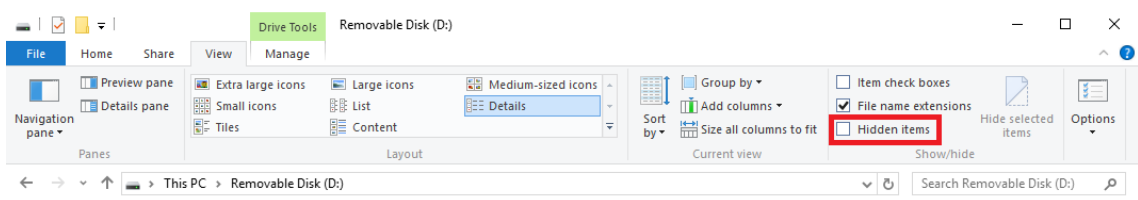

5.8.7 The contents of the microSD card

The root directory of the disk contains seven items:

- a file named `init.log`. This "write-once" file contains the first 32 MiB of system log information since the card was last formatted.
- a file named `system.log`. This "re-use" file contains the last 64 MiB of the system log;

Güralp Minimus and Minimus+

- a file named `status.log`. This “re-use” file contains the last 32 MiB of dumps of system state of health information. A new dump is generated every 20 minutes.
- a disk image file which Güralp technical support may ask you to use if you have problems with the card;
- a file named `table_of_events.bin`. This is not human readable: it is used by the Seismic Events Table in the “Trigger” tab
- a directory named `all_miniSEED_files_are_in_here`. Within this directory, there will be a miniSEED file for each recording channel. The file-name prefix is the same as the channel name description given in the “Data Record” tab. Each file is 128 MiB in size.

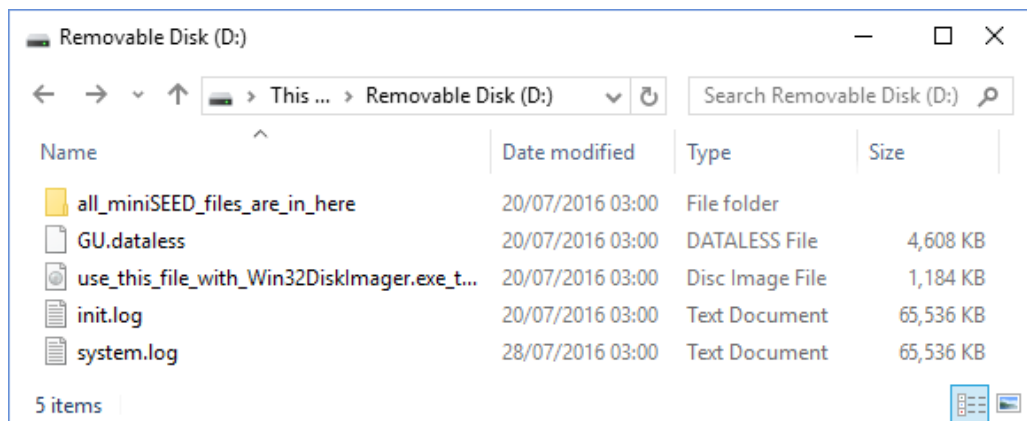

The typical contents of the `all_miniSEED_files_are_in_here` directory looks like this:

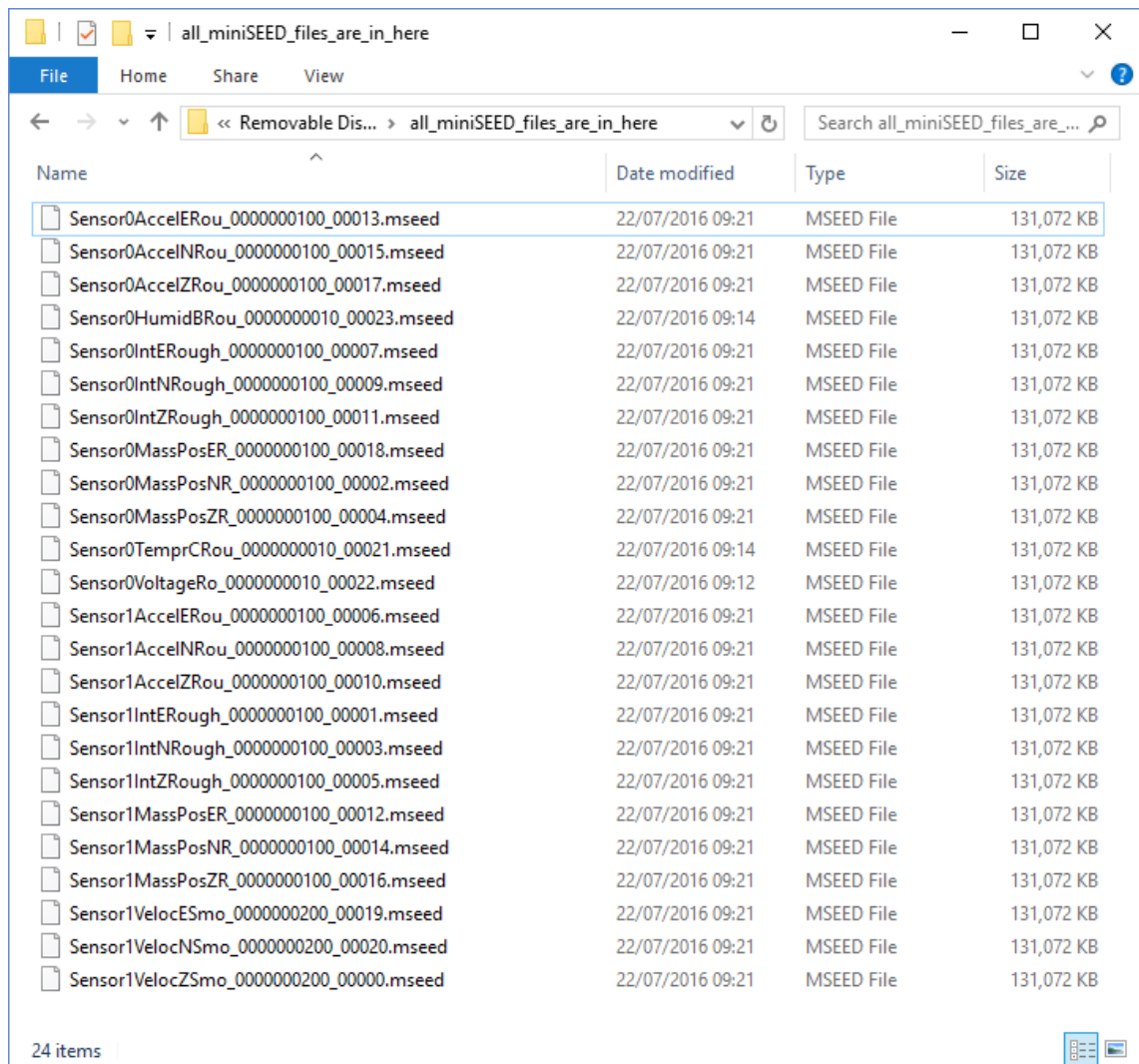

The file-name consists of four components:

- The stream name, truncated to 16 characters - see Section 8 on page **Error! Bookmark not defined.** for a full list of these;
- The sample rate (in samples per second) as a ten-digit decimal number, left-padded with zeros;
- A number which functions as a counter to ensure unique file-names for all files. Each time a file is created, this number is incremented so that the next file to be created will use the next value; and
- The `.mseed` extension which identifies this as a miniSEED file.

Güralp Minimus and Minimus+

The "Storage" tab also shows links to five auxiliary files, which are either saved in the Minimus' flash RAM or are dynamically generated:

Auxiliary files	
Filename	Description
DG.dataless	Dataless SEED file
fram.log	FRAM log file
calvals.txt	SCREAM! calibration values
polezero.txt	SCREAM! zeros, poles and gains
calib.txt	Calibration text file

- `network.DATALESS` : This is a dataless SEED volume that contains meta-data including instrument responses, coordinates, compression type and more. It is generated from the RESP files for each channel. The first component of the file name depends on the the two-character Network code defined in the "Setup" tab. If, for example, this is GU, the file is called `GU.DATALESS`.
- `fram.log` : this is the FRAM log file. It is stored in FRAM.
- `calvals.txt` : this file contains calibration information in a format compatible with the Scream software package. It is dynamically generated.
- `calib.txt` - this file contains calibration information with poles, zeros etc expressed in hexadecimal notation. It is stored in FRAM.
- `polezero.txt` : this file contains definitions of frequency responses in a format compatible with the Scream software application. It is dynamically generated.

5.8.8 Request data from microSD card

Discovery can be used as viewer of seismic data locally recorded in the microSD card of a Minimus.

Select the Minimus of interested, right-click and choose "Data calendar view" to open the complete list of streams.

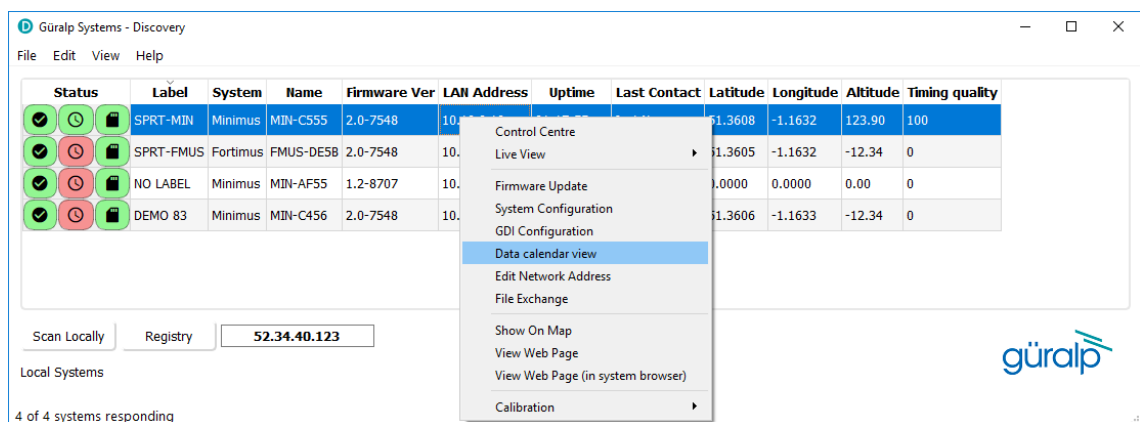

Güralp Minimus and Minimus+

The calendar shows two weeks of data preceding the time when the request is sent and it includes all the available channels recorded in the microSD card, distinct by stream name and predefined colour.

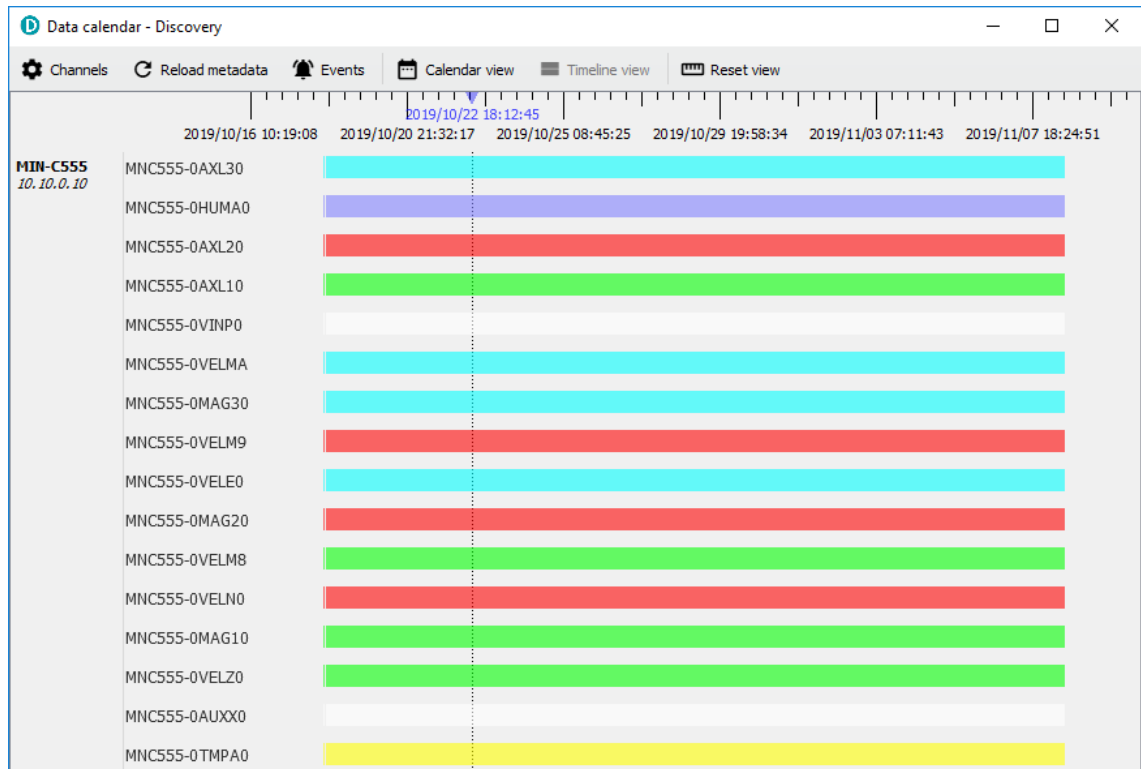

Note: Any gap in the calendar view is symptom of a gap in the recorded data.

Use the mouse-wheel scrolling (or track- / touch-pad scrolling on a laptop) or highlight a portion of data, right-click and select "Zoom in" to zoom into the data. Multiple channel are selectable using key .

In Discovery, right-click on the Minimus of interest and select "Live View" → "GDI" to open a data viewer window. Select the streams that are going to be backfilled with recorded data.

Güralp Minimus
and Minimus+

In the calendar window select the portion of data to backfill into the viewer. Right-click and select "Request backfill".

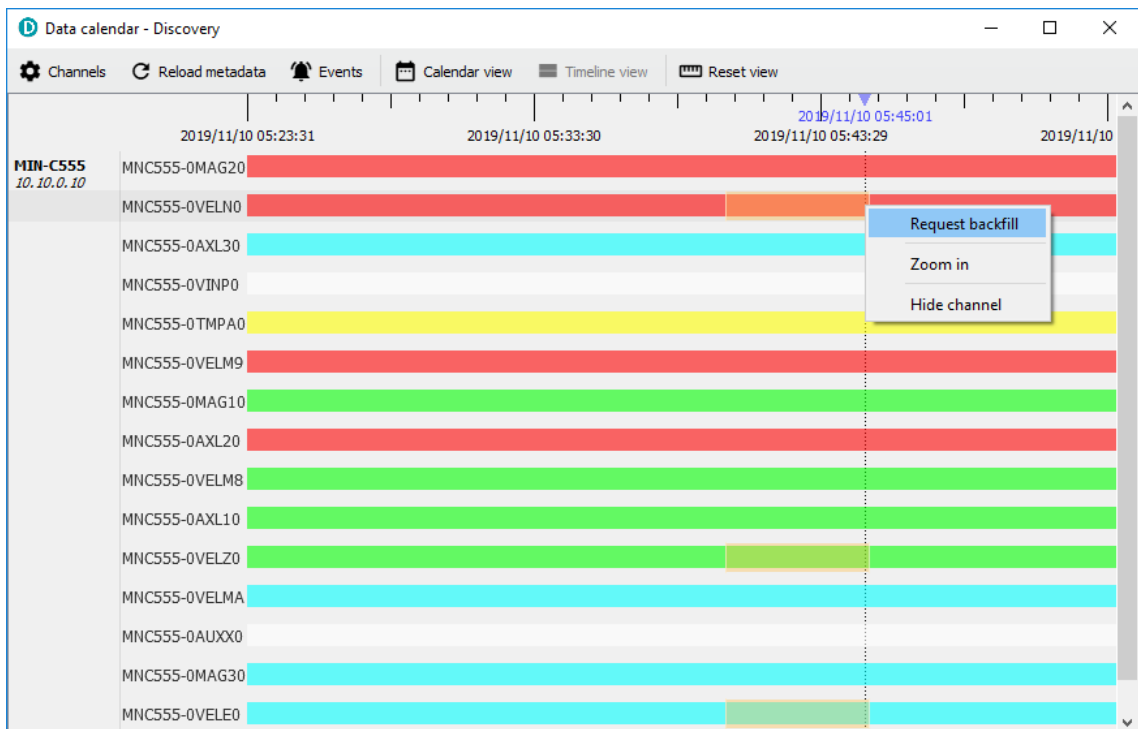

The requested data are automatically imported in the GDI data viewer in Discovery.

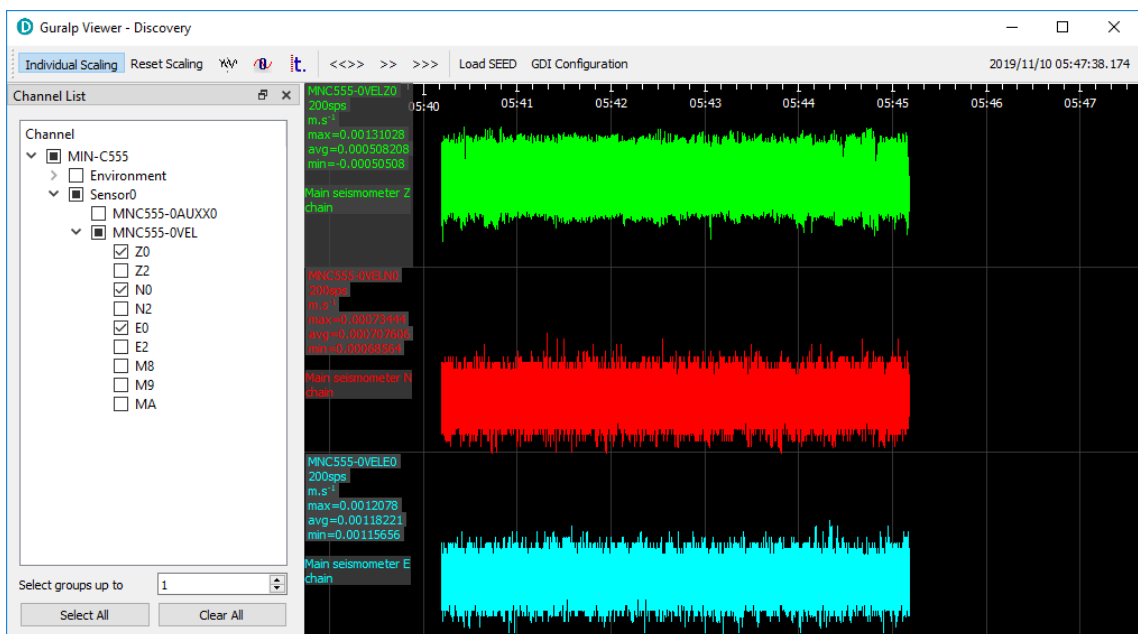

Note: The time required to upload the data depends on the window duration and the sample rate. Subsequent requests are queued and a new one is served once the previous one is completed.

5.9 Data transmission

The monitoring and configuration of transmitted data is handled using the “Data Stream” tab of the instrument’s web page.

Channel sampling rate	Data transform	SEED name - please use check-box to modify the default	RESPonse file - if available
Seismic channels			
0AUX0	200 Hz	Transforms Disabled for this tap	<input type="checkbox"/> DG.TEST,00 ,HDF RESP_file_5
0VELZ0	200 Hz	Transforms Disabled for this tap	<input type="checkbox"/> DG.TEST,00 ,HHZ RESP_file_7
0VELN0	200 Hz	Transforms Disabled for this tap	<input type="checkbox"/> DG.TEST,00 ,HHN RESP_file_11
0VELE0	200 Hz	Transforms Disabled for this tap	<input type="checkbox"/> DG.TEST,00 ,HHE RESP_file_15
0VELZ2	5 Hz	Transforms Disabled for this tap	<input type="checkbox"/> DG.TEST,00 ,MHZ RESP_file_8
0VELN2	5 Hz	Transforms Disabled for this tap	<input type="checkbox"/> DG.TEST,00 ,MHN RESP_file_12
0VELE2	5 Hz	Transforms Disabled for this tap	<input type="checkbox"/> DG.TEST,00 ,MHE RESP_file_16
Mass position channels			
0VELM8	100 Hz	Transforms Disabled for this tap	<input type="checkbox"/> DG.TEST,00 ,HMZ
0VELM9	100 Hz	Transforms Disabled for this tap	<input type="checkbox"/> DG.TEST,00 ,HMN
0VELMA	100 Hz	Transforms Disabled for this tap	<input type="checkbox"/> DG.TEST,00 ,HME
MEMS accelerometer channels			
0AXL10	100 Hz	Transforms Disabled for this tap	<input type="checkbox"/> DG.TEST,99 ,HN1 RESP_file_31
0AXL20	100 Hz	Transforms Disabled for this tap	<input type="checkbox"/> DG.TEST,99 ,HN2 RESP_file_35
0AXL30	100 Hz	Transforms Disabled for this tap	<input type="checkbox"/> DG.TEST,99 ,HN3 RESP_file_39



This page allows to configure the transmitted channels for each of the connected instruments and sensors internal to the Minimus.

The names and contents of each channel are described in Section 8 on page **Error!**
Bookmark not defined.

Note: When changing a setting in the Minimus web page, ensure that you wait until the page refreshes before changing another setting. This allows time for the previous change to take effect.

The drop-down box at the top-left of the page named “Display Streams” filters out visible channels among Enabled and Disabled. The option “Apply configuration for tap groups” automatically apply the same configuration to three streams that belong to the same tap, *e.g.* 0VELZ0, 0VELN0, 0VELE0. The drop-down box at the top-right of the page named “Display On Page” allows to move from different instruments, *e.g.* Sensor 1.

The page is divided in four columns:

- in most-left column, drop-down boxes are available for each channel to either select a sample rate or to exclude the channel from streaming (by selecting the “Disabled” option). All streaming can be stopped by clicking the  button. Same configuration can be applied to recorded channels by clicking the  button. Default channel configuration can be applied by clicking the  button.
- in second column from the left, drop-down boxes are available for each channel to enable/disable transforms and, once transform is enabled, to select the transform to apply (see Section 5.15 on page **Error! Bookmark not defined.**);
- in third column from left, Location and Channel SEED codes can be configured. Cells are greyed out by default (default values applied) and they can be edited by clicking on the check-box;
- in most-right column contains links to the RESP files associated to each of the seismic channels (see Section 5.12.5 on page **Error! Bookmark not defined.**).

Upon changing the sample rate, enabling a transform or changing Location and Channels codes, the Minimus will need to be restarted for the changes to come into effect; this can be done by pressing the  button.

During the reboot, the LEDs will flash, displaying the starting-up sequence (see Section 3.1.1 on page **Error! Bookmark not defined.**) and the instrument web page will display the following screen.

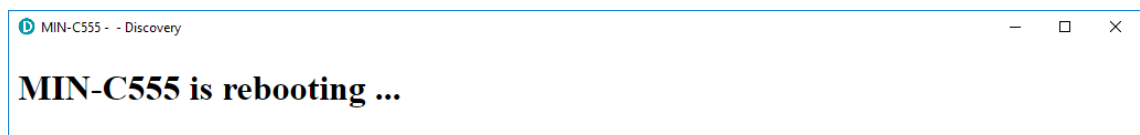

Once the Minimus has successfully restarted, the full web browser display and controls will be available for use again.

5.9.1 Scream! (GCF format + Scream protocol)

The Minimus can act as a Scream! Server and stream data by sending GCF (Güralp Compressed Format) packets over a network connection using the scream data-transmission protocol.

This is primarily intended to support Güralp's Scream! Software (see Section 4.3.2 on page **Error! Bookmark not defined.**) or any software that can communicate using the Scream! Protocol, including Earthworm.

These include:

- Güralp instruments with embedded acquisition modules (*e.g.* 40TDE)

Güralp Minimus and Minimus+

- Güralp DM24 and CD24 digitisers with embedded acquisition modules (*e.g.* Güralp DM24SxEAM[U])
- Güralp Affinity digitiser
- Network Acquisition Module (Güralp NAM)

Note: Güralp devices running the Platinum software *can* receive GCF data over the Scream protocol, but the GDI-link protocol is preferred in these cases.

5.9.2 GDI-link protocol

The Minimus can transmit data using the GDI-link protocol. GDI-link can currently be used with:

- Güralp instruments with embedded acquisition modules (*e.g.* 40TDE)
- Güralp DM24 and CD24 digitisers with embedded acquisition modules (*e.g.* Güralp DM24SxEAM[U])
- Güralp Affinity digitisers
- Güralp NAM (Network Acquisition Module)
- Earthworm software (www.isti.com/products/earthworm/)

GDI-link supports both data push and pull from/to the Minimus. See Section 5.5 on page **Error! Bookmark not defined.** to configure data push to one or more remote clients, *e.g.* NAM.

GDI-link provides a highly efficient, low latency method of exchanging data via TCP between seismic stations and data centres. The protocol allows state-of-health information to be attached to samples during transmission. The topology can be many-to-one or one-to many. This means that a receiver can accept data from multiple transmitters and a single transmitter can send data to multiple receivers, allowing maximum flexibility for configuring seismic networks. GDI-link streams data sample-by-sample (instead of assembling them into packets) to minimise transmission latency.

A significant advantage of GDI-link is that it has the ability to stream data pre-converted into real physical units instead of just as raw digitiser counts, obviating a requirement for receivers to be aware of calibration values.

For more information on GDI-link, please refer to Güralp manual **SWA-RFC-GDIL**.

5.9.3 SEEDlink protocol

The Minimus can act as a SEEDlink server to send miniSEED data packets over a network connection. The SEEDlink server is enabled by default but it can be disabled and re-enabled if desired. The server has a configurable back-fill buffer.

Note: The Minimus SEEDlink back-fill implementation is packet-based.

In the “Network” tab of the Minimus' web page, select the desired SEEDlink mode:

Network Config				
DHCP <input type="checkbox"/> Enabled <input type="checkbox"/>				
DNS1 <input type="text" value="209.244.0.3"/>	DNS2 <input type="text" value="84.200.69.80"/>			<input type="button" value="Reboot"/>
Web Login <input type="checkbox"/> Required <input type="checkbox"/>	Username (Normal) <input type="text" value="user"/>	Password (Normal) <input type="password" value="*****"/>	HTTP Port <input type="text" value="80"/>	
Web Timeout <input type="checkbox"/> Never <input type="checkbox"/>	Username (Admin) <input type="text" value="admin"/>	Password (Admin) <input type="password" value="*****"/>		
SeedLink <input type="checkbox"/> Enabled, 65536 records <input type="checkbox"/> Disabled	Send status.txt Every <input type="text" value="300"/> seconds	SeedLink Data Packet Format <input type="checkbox"/> Optimal <input type="checkbox"/>	Send SeedLink EEW Packet Every <input type="text" value="0"/> deciseconds	
TFTP Server <input type="checkbox"/> Debug, 512 records	TFTP File <input type="text"/>			
Network <input type="checkbox"/> Debug, 2048 records				
PTP Mode <input type="checkbox"/> Run <input type="checkbox"/>	PTP Offset Correction <input type="text" value="0"/> nanoseconds	PTP Transmission Mode <input type="checkbox"/> Unicast <input type="checkbox"/>	PTP Master IP <input type="text" value="0.0.0.0"/>	
NTP Server <input type="checkbox"/> Enabled, 2048 records				
Registry <input type="checkbox"/> Enabled, 65536 records				
Registry Update <input type="checkbox"/> Enabled, 139264 records	Group ID <input type="text" value="SOF"/>	Registry Address <input type="text" value="52.34.40.123"/>		

The choices are:

- “Enabled” - This is the normal operating mode. Choose between backfill buffer sizes of 2,048 records, 65,536 records or 139,264 records;
- “Disabled” - turns off the SEEDlink server; and
- “Debug” - this mode produces additional messages in the file `seedlink.log` which may be helpful if trying to diagnose a problem. It is available with backfill buffer sizes as before and, additionally, a 512-record buffer. (622,592 is listed but not implemented).

Note: As a general guide, we find that 139,264 records is normally sufficient to store around one day of triaxial, 100 sps data.

Standard SEEDlink has a fixed packet size of 512 Bytes and each miniSEED packet is completely populated with data before it is transmitted. The Minimus supports a modified version of SEEDlink that allows the transmission of incomplete packets. This improves latency.

Note: The modified SEEDlink is only available for EEW channels - *i.e.* the main seismic channels (generated with causal low latency filters) and the STA, LTA, STA/LTA ratio channels.

The user can specify the rate at which miniSEED packets must be transmitted. If populating complete packets would result in this rate not being achieved, incomplete packets are transmitted instead. The number of samples in each packet, therefore, depends both upon this setting and on the sample rate.

Güralp Minimus
and Minimus+

In the “Network” tab of the Minimus web page select the interval in deciseconds (1 decisecond = 100 ms or 0.1 seconds) between miniSEED packets (“Send SeedLink EEW Packets Every”).

Network Config				
DHCP <input type="checkbox"/> Enabled				
DNS1	<input type="text" value="209.244.0.3"/>	DNS2	<input type="text" value="84.200.69.80"/>	<input type="button" value="Reboot"/>
Web Login	<input type="checkbox"/> Required	Username (Normal)	<input type="text" value="user"/>	Password (Normal) <input type="text" value="*****"/> HTTP Port <input type="text" value="80"/>
Web Timeout	<input type="checkbox"/> Never	Username (Admin)	<input type="text" value="admin"/>	Password (Admin) <input type="text" value="*****"/>
SeedLink	<input type="checkbox"/> Enabled, 65536 records	Send status.txt Every	<input type="text" value="300"/> seconds	SeedLink Data Packet Format <input type="checkbox"/> Optimal <input type="checkbox"/> Send SeedLink EEW Packet Every <input type="text" value="10"/> deciseconds
Data Record Size	<input type="checkbox"/> 512 Bytes	TFTP Server	<input type="text" value="10.30.255.197"/>	TFTP File <input type="text"/>

The modified SEEDlink protocol also allows the use of 256-byte records as an alternative to the standard 512-byte format. The “Data Record Size” drop-down menu on the “Network” tab of the Minimus web page controls this behaviour.

Network Config				
DHCP <input type="checkbox"/> Enabled				
DNS1	<input type="text" value="209.244.0.3"/>	DNS2	<input type="text" value="84.200.69.80"/>	<input type="button" value="Reboot"/>
Web Login	<input type="checkbox"/> Required	Username (Normal)	<input type="text" value="user"/>	Password (Normal) <input type="text" value="*****"/> HTTP Port <input type="text" value="80"/>
Web Timeout	<input type="checkbox"/> Never	Username (Admin)	<input type="text" value="admin"/>	Password (Admin) <input type="text" value="*****"/>
SeedLink	<input type="checkbox"/> Enabled, 65536 records	Send status.txt Every	<input type="text" value="300"/> seconds	SeedLink Data Packet Format <input type="checkbox"/> Optimal <input type="checkbox"/> Send SeedLink EEW Packet Every <input type="text" value="10"/> deciseconds
Data Record Size	<input type="checkbox"/> 512 Bytes <input type="checkbox"/> 256 Bytes	TFTP Server	<input type="text" value="10.30.255.197"/>	TFTP File <input type="text"/>
Network Timing				
PTP	<input type="text"/>	PTP Offset	<input type="text"/>	PTP

Note: Not all SEEDlink clients can accept 256-byte records. Consult your client's documentation if in doubt.

To test the SEEDlink server, Güralp recommends using the *slinktool* software for Linux, which is distributed by IRIS. For more information and to download a copy, see <http://ds.iris.edu/ds/nodes/dmc/software/downloads/slinktool/>.

To show a list of available miniSEED streams, issue the command:

```
slinktool -Q IP-Address
```

Which produces output like the following:

```
DG TEST 00 CHZ D 2016-09-13 10:42:18 - 2016-09-13 10:46:56
DG TEST 01 HHZ D 2016-09-13 10:42:18 - 2016-09-13 10:46:56
DG TEST 00 CHN D 2016-09-13 10:42:18 - 2016-09-13 10:46:56
DG TEST 01 HHN D 2016-09-13 10:42:18 - 2016-09-13 10:46:56
DG TEST 00 CHE D 2016-09-13 10:42:18 - 2016-09-13 10:46:56
DG TEST 01 HHE D 2016-09-13 10:42:18 - 2016-09-13 10:46:56
```

Güralp Minimus and Minimus+

```
DG TEST 00 MHZ D 2016-09-13 10:42:18 - 2016-09-13 10:46:56
DG TEST 00 MHN D 2016-09-13 10:42:18 - 2016-09-13 10:46:56
DG TEST 00 MHE D 2016-09-13 10:42:18 - 2016-09-13 10:46:56
:
```

To print miniSEED data records of a single channel, you will need the following command:

```
slinktool -p -S DG_TEST:00HNZ.D IP-Address
```

Which produces the following output:

```
DG_TEST_00_HNZ, 412 samples, 100 Hz, 2016,257,10:43:42.000000 (la-
tency ~2.9 sec)
DG_TEST_00_HNZ, 415 samples, 100 Hz, 2016,257,10:43:46.120000 (la-
tency ~2.6 sec)
DG_TEST_00_HNZ, 416 samples, 100 Hz, 2016,257,10:43:50.270000 (la-
tency ~3.0 sec)
DG_TEST_00_HNZ, 413 samples, 100 Hz, 2016,257,10:43:54.430000 (la-
tency ~2.6 sec)
DG_TEST_00_HNZ, 419 samples, 100 Hz, 2016,257,10:43:58.560000 (la-
tency ~3.0 sec)
DG_TEST_00_HNZ, 418 samples, 100 Hz, 2016,257,10:44:02.750000 (la-
tency ~2.6 sec)
DG_TEST_00_HNZ, 415 samples, 100 Hz, 2016,257,10:44:06.930000 (la-
tency ~3.0 sec)
:
```

The SEEDlink server on the Minimus also supports the use of the “?” character as a wild-card within network, station and channel codes. This allows you to request multiple streams using a single command.

Note: Because the ? character has special meaning to the shell, it is safest to quote this character with a preceding backslash ('\') when used in command arguments.

Güralp Minimus and Minimus+

5.9.3.1 MiniSEED extractor

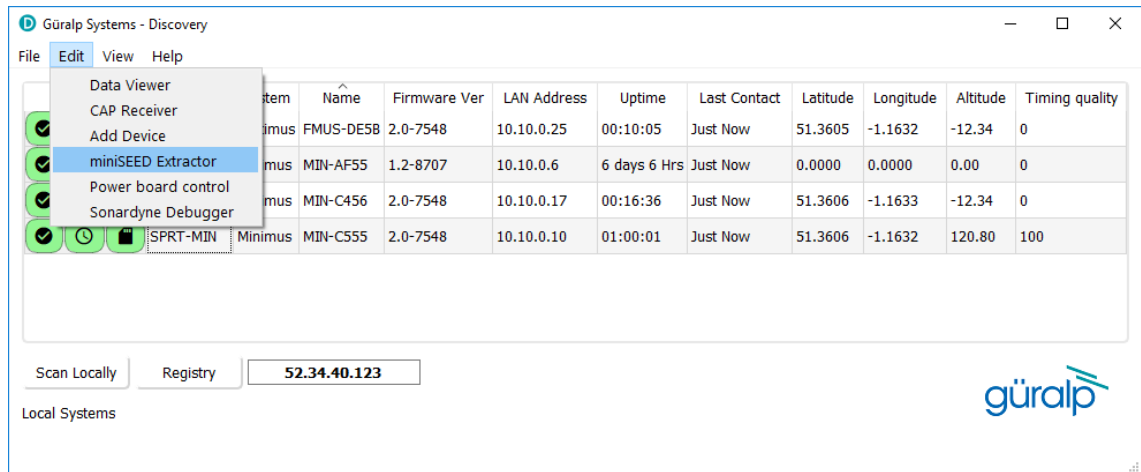

The miniSEED extractor serves two purposes:

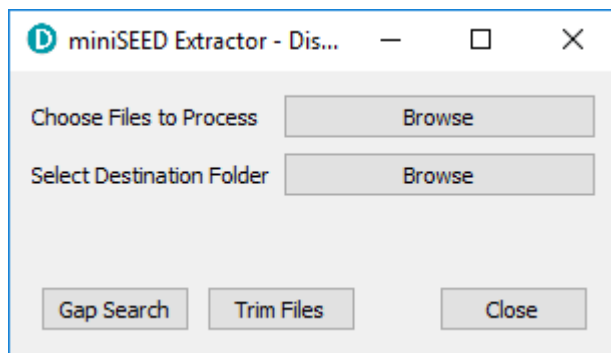

- When an SD card is quick-formatted, each file is marked as unused but previously recorded data can still remain in them. Subsequent recordings overwrite these files from the beginning but, if the previous recording had a longer duration, old data will remain in the files. When the files are copied from the SD card to a PC, these older data can cause problems.
- The format used on the SD cards consists of fixed-length, 128 MiB files. Some recordings might not use all of this space. When the files are copied from the SD card to a PC, this can cause wasted disk space.

The miniSEED extractor reads miniSEED files on the PC and copies them to a selected Destination folder, keeping track of the latest block time-stamp as it goes. If it encounters either an unused block or a time-stamp which is earlier than the previous one, it stops copying, truncating the output file at that point. This guarantees that each output file contains only blocks in time order and contains no wasted space.

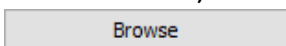

To use the tool, select "miniSEED Extractor" from the Edit menu. Click the first  button to select which files you wish to process and then the

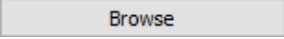
Güralp Minimus and Minimus+

second  button to select the folder into which you wish the output files to be written. Finally, click the  button to extract the valid data from the selected files into new files in the selected destination folder.

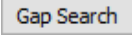
The same tool can also generate a report of any gaps in the data from the input files. To use, select the input files as before and then click  to view the report.

5.10 Synchronisation of the sample-clock

The Minimus system synchronises its sample clock using an attached GNSS receiver or, if that is not available, Precision Time Protocol (PTP).

The currently supported GNSS systems are Navstar (GPS), GLONASS, BeiDou and Galileo.

Note: The GNSS can use only three different types of satellites simultaneously and GPS is always used, if available. The other two spots available can be either GLONASS, BeiDou or Galileo.

If visibility of the satellite constellation is available, this is the most accurate way to synchronise your digitiser. The Minimus accessory pack includes a combined GNSS antenna and receiver for this purpose: see Section 3.2.2 on page **Error! Bookmark not defined.** for details.

Güralp Minimus and Minimus+

5.10.1 GNSS lock status

This is available in the “Status” tab of the instrument’s web page.

The screenshot shows the Minimus web interface. At the top, there is a navigation menu with options: Status, Network, Setup, Trigger, Data Stream, Data Record, Storage, Logout, and Help. Below the menu, system information is displayed: System type: Minimus | Host label: SPRT-MIN | Host name: MIN-C555 (10.10.0.10) | Serial number: 00C555.

The main content area is divided into several sections:

- System Status**: A table with columns for Host name, Serial number, Digitiser temperature, System time, Host label, Firmware version, Digitiser humidity, Uptime, System type, IPv4 address, Input voltage, ETH status, Product type, and Power over Ethernet voltage.
- GNSS Status**: A table with columns for GNSS connection status, Last timestamp, Last lock time, Latitude, Altitude, GNSS PPS status, and GNSS Lock state. It also includes a map showing the location of the instrument near London.
- Data record status**: A table with columns for microSD status, microSD total, microSD used, and microSD free.
- Sensors**: A table with columns for Number of sensors detected, Sensor0, Serial number (0), Integrator Z (0), Seismometer Z (0), Firmware ver (0), Integrator N (0), Seismometer N (0), Integrator E (0), and Seismometer E (0).

At the bottom of the page, contact information for Güralp Systems Limited is provided: Midas House, Calleva Park, Aldermaston, Reading, RG7 8EA, UK. Tel: +44 118 981 9056, Fax: +44 118 981 9943. E-Mail: sales@guralp.com, support@guralp.com.

A number of GNSS reporting parameters are given, including:

- Connection status
- Last GNSS update (sync) & last GNSS lock date/time
- GNSS Stability:
 - 0% = no receiver connected;
 - 1% = receiver connected, but waking up (this can occur if the GNSS receiver has been moved a long distance since last power-up).
 - 2-99% = view of sky obstructed.
 - 100% = normal operation with clear view of sky
- Latitude, longitude, altitude
- Horizontal dilution of precision (quality of satellite fix due to position of satellites relative to receiver)
- GNSS PPS status

Güralp Minimus and Minimus+

- GNSS NMEA streaming
- GNSS lock state (2D/3D)
- Number of available satellites (in use / in view)

5.10.2 PTP (Precision Time Protocol)

The Minimus system supports timing provided through PTP.

The screenshot displays the Minimus web interface. At the top, there is a navigation menu with options: Status, Network, Setup, Trigger, Data Stream, Data Record, Storage, Logout, and Help. The system type is identified as Minimus, with host label SPRT-MIN and host name MIN-C555 (10.10.0.10). The serial number is 00C555.

System Status

General information					
Host name	MIN-C555	Host label	SPRT-MIN	System type	Minimus
Serial number	00C555	Firmware version	2.0-7548	IPv4 address	10.10.0.10 (DHCP)
Digitiser temperature	29.019 °C	Digitiser humidity	26.12%	Input voltage	12.966 V
System time	9:05:15 AM Fri 8-Nov-2019	Uptime	16h 53m 3s	ETH status	sckt: 12/20 data: 2/6

GNSS Status

GNSS connection status	Disconnected	Last timestamp	0000-00-00 00:00:00
Last lock time	Never	GNSS stability	Disconnected
Latitude	51.3606	Longitude	-1.1633
Altitude	-12.34	Horizontal dilution of precision	Undefined
GNSS PPS status	Not Trusted No Pulse	GNSS NMEA stream	Bad input
GNSS Lock state	No lock	Number of satellites	Used: 0 In view: 0

PTP Status

PTP state	Phase Locked	Last PTP timestamp	2019-11-08 09:14:40Z	Last PTP lock time	2019-11-08 08:59:22Z	PTP stability	100%
Master IPv4 address	10.30.255.35	Master clock class	PRI_REF_PTP	Master clock accuracy	< 100ns (0x21)	Master time source	GPS
Network path delay	38.1 us	Network jitter estimate	± 983 ns	Network outliers	4%		

Data record status

microSD status	Recording	microSD total	60686336 KiB	microSD used	1299032 KiB	microSD free	97%
----------------	-----------	---------------	--------------	--------------	-------------	--------------	-----

Sensors

Number of sensors detected	1					
Sensor0	Serial number (0)	TF064	Firmware ver (0)	6.0		
	Integrator Z (0)	-6	Integrator N (0)	-5	Integrator E (0)	-6
	Seismometer Z (0)	64	Seismometer N (0)	287	Seismometer E (0)	483

At the bottom of the interface, contact information for Güralp Systems Limited is provided: Midas House, Calleva Park, Aldermaston, Reading, RG7 8EA, UK. Tel: +44 118 981 9056, Fax: +44 118 981 9943. E-Mail: sales@guralp.com, support@guralp.com.

The IEEE 1588 Precision Time Protocol (PTP) is a network protocol which uses modified network hardware to accurately time-stamp each PTP packet on the network at the time of transmission, rather than at the time that the packet was assembled. If you do not have an existing PTP infrastructure, the simplest way to use PTP is to add a "grand-master clock" to the same network segment as the digitisers. A typical such clock is the Omicron OTMC 100, which has an integrated GNSS antenna and receiver which it uses as its own synchronisation source. PTP timing can be extended over up to 100 metres of Ethernet cable or longer distances when fibre-optic cable is used. PTP is significantly more accurate than NTP but generally requires specialised hardware support.

Güralp Minimus and Minimus+

In the “Status” tab of the Minimus web page, a number of reporting parameters are given, including:

- PTP state
- Last PTP time-stamp and last PTP lock date/time
- PTP Stability:
 - Standby ⇒ PTP is running but timing is provided by GNSS;
 - No Master ⇒ PTP not available;
 - 1-100% ⇒ PTP locking process indicator. 100% indicates a time accuracy of better than 200 ns.
- Master IPv4 address
- Master clock class and accuracy
- Master time source
- Network path delay
- Network jitter estimate: quality indicator
- Network outliers

Under the heading “Network config” are four options:

- **Disabled** ⇒ PTP is never used (default settings).
- **Run if needed – Offline backup** ⇒ PTP is automatically enabled whenever the GNSS signal is lost. It is disabled while GNSS is available. This mode is used to minimise network traffic when GNSS is the primary timing source.
- **Run always – Online backup** ⇒ PTP is always running but GNSS is used as the primary timing source. This mode is useful for faster fall-back from GNSS to PTP timing and for validation that PTP is available.
- **Run always – Override GPS** = PTP is always running and takes priority over GNSS. This mode is useful in a system where PTP is the primary timing source, but GNSS may occasionally be connected for validation purposes.

Network Timing							
PTP Mode	Run always - Override GPS Disabled	PTP Offset Correction	0 nanoseconds	PTP Transmission Mode	Unicast	PTP Master IP	0.0.0.0
NTP Se	Run if needed - Offline backup						
Regi	Run always - Online backup						
Regist	Run always - Override GPS	Group ID	SOF	Registry Address	52.34.40.123		

PTP can be configured for multicast or unicast mode. In unicast mode, the server I.P. address must be specified. This is available in the “Network” tab of the digitiser’s web page.

Güralp Minimus and Minimus+

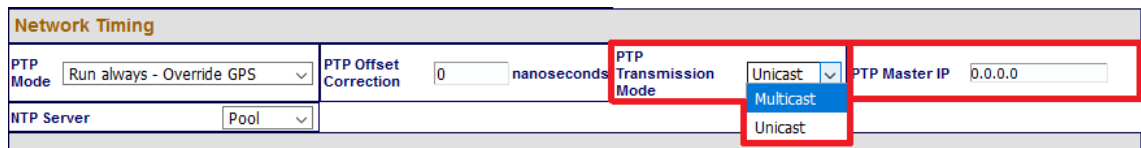

5.10.2.1 Special notes for PTP with Maris ocean-bottom systems.

PTP is the only source of timing available for a deployed Maris digitiser. To configure, visit the “Network” tab of the digitiser web page.

If your PTP infrastructure produces a fixed offset (when compared with GNSS), a manual correction can be applied to compensate for this.

The required correction value can be extracted from the internal clock from GNSS stream of the Minimus. In the Live View enable the `0CGPSO` channel and select at least 20 minutes of data. Right-click on the selection and click on Show Samples:

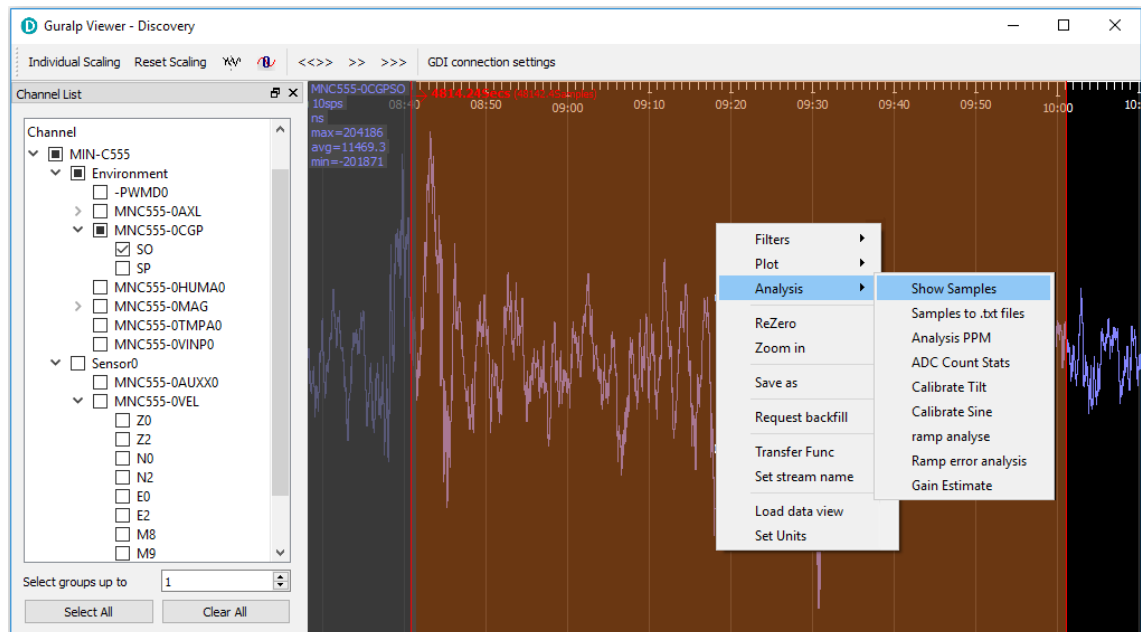

Güralp Minimus
and Minimus+

At the top of the resulting window, the maximum (max), average (avg) and minimum (min) values are displayed:

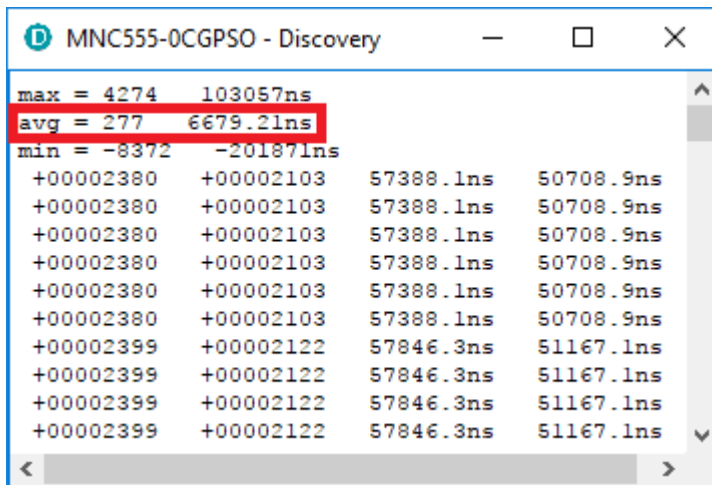

Note the value of the average, multiply by -1 and enter the resulting value in the PTP Offset Correction box in the Network Timing section of the Network web page.

5.11 Deploy mode: Full power-save

The Minimus digitiser offers two deployment modes: "Normal" and "Power Save". "Full power-save" mode makes a number of configuration changes in order to reduce the unit's power consumption. This mode is particularly useful when using Maris digital ocean-bottom sensors.

The desired mode can be specified using the "Deploy mode" drop-down menu in the "Setup" tab of Minimus web page. Changes are not applied immediately.

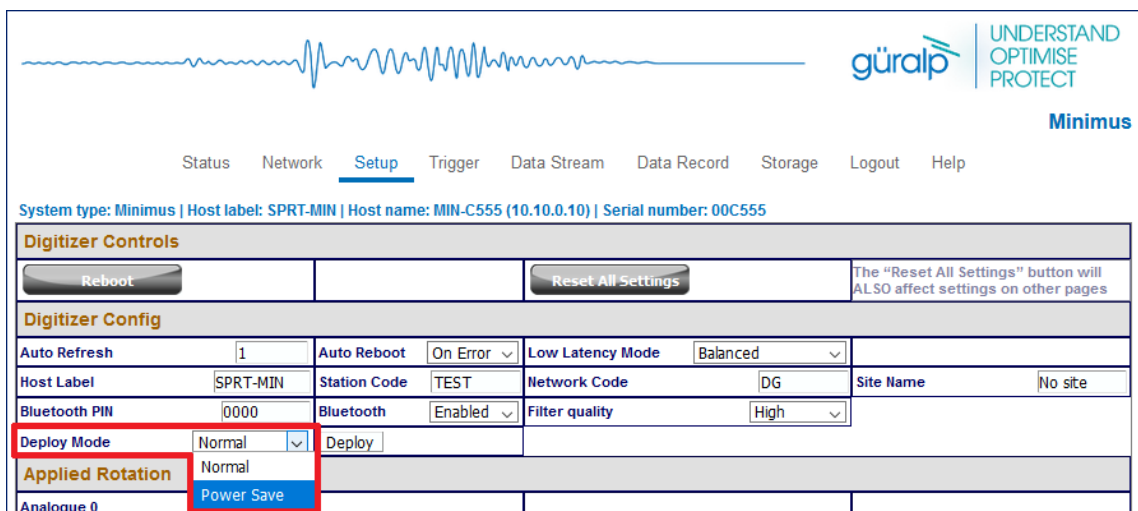

"Power Save" mode temporarily disables auto-centring of a connected the Maris digital sensor, so that it is not continually re-centring while being lowered to the sea floor. When this mode is selected, the "Auto Centre Disable (hr)" input field appears: use this to specify the length of time before auto-centring is re-enabled.

Güralp Minimus
and Minimus+

Digitizer Config					
Auto Refresh	1	Auto Reboot	On Error	Low Latency Mode	Balanced
Host Label	SPRT-MIN	Station Code	TEST	Network Code	DG
Bluetooth PIN	0000	Bluetooth	Enabled	Filter quality	High
Deploy Mode	Power Save	Auto Center Disable(hr)	12	Deploy	

Note: Güralp recommend a value of 10 to 12 hours to fully cover the entire deployment procedure.

The final step is to click on the **Deploy** button and confirm or cancel the operation from the pop-up window that appears.

Digitizer Controls					
Reboot		Reset All Settings		The "Reset All Settings" button will ALSO affect settings on other pages	
Digitizer Config					
Auto Refresh	1	Auto Reboot	On Error	Low Latency Mode	Balanced
Host Label	SPRT-MIN	Station Code	TEST	Network Code	DG
Bluetooth PIN	0000	Bluetooth	Enabled	Filter quality	High
Deploy Mode	Power Save	Auto Center Disable(hr)	12	Deploy	
Applied Rotation					
Analogue 0	0	Digital 1	0	Digital 2	0
Digital 3	0	Digital 4	0	Digital 5	0
Digital 6	0	Digital 7	0	Digital 8	0

System is about to be deployed. Are you sure?

A thirty-second count-down will start before the system enters power-save mode. The screen changes and a new button is added:

Digitizer Controls					
Reboot		Reset All Settings		The "Reset All Settings" button will ALSO affect settings on other pages	
Digitizer Config					
Auto Refresh	1	Auto Reboot	On Error	Low Latency Mode	Balanced
Host Label	SPRT-MIN	Station Code	TEST	Network Code	DG
Bluetooth PIN	0000	Bluetooth	Enabled	Filter quality	High
Deploy Mode	Power Save	Auto Center Disable(hr)	12	Deploy	Abort deployment
You can abort deployment within		28s			

You can cancel the operation before the countdown is complete by clicking the **Abort deployment** button.

Caution: The power-save mode will disable the Ethernet and GNSS modules. You will not be able to continue to use the web interface.

Once in deploy mode, the only way to re-enable the Ethernet module is to connect to the Minimus via a serial connection (see Section 7 on page **Error! Bookmark not defined.**) or to use the GüVü Bluetooth app (see Section 6.4 on page **Error! Bookmark not defined.**).

Güralp Minimus and Minimus+

When a serial or Bluetooth connection is established, type the command `power-save off` in the console to disable the "Full power-save" mode and re-enable Ethernet communication.

5.12 Configuration and control of connected analogue instruments

5.12.1 Setting instrument type

The analogue sensor type is user-selectable and the Minimus includes a choice of several Güralp sensors and accelerometers. If the sensor is not in the list, select "Generic velocity" or "Generic acceleration", according to the instrument's response.

Analogue Sensors			
Analogue to Digital Converter			
Input gain	<input type="text" value="x1.0"/>	Input range	+/- 20.48 V
		Input resolution	2.441 uV/count
Identification			
Sensor type	<input type="text" value="Guralp 3T"/>	Status LED	Idle
Mass Centring			
Centre Mass	<input type="text" value="Guralp 3T"/>	Mass Readout Z	-0.00375 V
		Mass Readout N	-0.00312 V
		Mass Readout E	-0.00375 V
Mass Locking			
Lock Mass	<input type="text" value="Guralp Fortis"/>	Unlock Mass	<input type="text" value=""/>
Calibration			
Calibration	<input type="text" value="Guralp 5TC"/>	Amplitude	<input type="text" value="100%"/>
		Channel	<input type="text" value="Normal"/>
Digital Se	<input type="text" value="Guralp 6T"/>		
	<input type="text" value="Guralp 3TB"/>		
Initialisation	<input type="text" value="Guralp 3V/3ESP-V"/>		
	<input type="text" value="Guralp 3T5TB"/>		
	<input type="text" value="Guralp 54T"/>		
	<input type="text" value="Generic velocity"/>		
	<input type="text" value="Generic acceleration"/>		

Güralp Systems Limited
 Midas House, Calleva Park, Aldermaston, Reading, RG7 8EA, UK
 Tel: +44 118 981 9056, Fax: +44 118 981 9943
 E-Mail: sales@guralp.com, support@guralp.com

A reboot is required after this change.

5.12.2 Setting instrument (sensor) gain for Güralp Fortis

The Güralp Fortis strong-motion accelerometer features a remotely-switchable gain option that can be controlled from inside Discovery. First, ensure that the physical gain switch on the underside of the Fortis is set to position "3" (as indicated by the engraving). See **MAN-FOR-0001** for more details.

To change the gain electronically, first, set the "Instrument Type" to "Güralp Fortis". Setting this option will then enable the "Instrument Gain" control. Under the "Instrument Gain", select a gain setting (options: $\pm 0.5g$; $\pm 1g$; $\pm 2g$; $\pm 4g$).

Setting the instrument type to "Fortis" will also change the miniSEED channel names to indicate that data are recorded from an accelerometer, *e.g.* "HNZ".

Analogue Sensors			
Analogue to Digital Converter			
Input gain	<input type="text" value="x1.0"/>	Input range	+/- 20.48 V
		Input resolution	2.441 uV/count
Identification			
Sensor type	<input type="text" value="Guralp Fortis"/>		
Response			
Fortis Range	<input type="text" value="-0.5g; +0.5g"/>	Fortis Loop	<input type="text" value="Normal"/>
	<input type="text" value="-0.5g; +0.5g"/>		
Mass Centring			
Centre Mass	<input type="text" value="-1.0g; +1.0g"/>	Mass Readout Z	-0.00375 V
		Mass Readout N	-0.00312 V
		Mass Readout E	-0.00375 V
Calibration			
Calibration	<input type="text" value="-2.0g; +2.0g"/>	Amplitude	<input type="text" value="100%"/>
	<input type="text" value="-4.0g; +4.0g"/>	Channel	<input type="text" value="Normal"/>

Güralp Minimus and Minimus+

5.12.3 Setting digitiser gain

The input gain can be controlled from the "Setup" tab of the web page using the "Input Gain" drop-down box. Digitiser gain options available are: Unity, $\times 2$, $\times 4$, $\times 8$ and $\times 12$.

Analogue Sensors			
Analogue to Digital Converter			
Input gain	x1.0	Input range	+/- 20.48 V
	x1.0	Input resolution	2.441 uV/count
Sensor type	Güralp Fortis	Identification	
	x2.0	Response	
Fortis Range	-0.5g	Fortis Loop	Normal
	x4.0	Mass Centring	
	x8.0	Mass Readout Z	-0.00375 V
Centre Mass	x12.0	Mass Readout N	-0.00312 V
		Mass Readout E	-0.00375 V
Calibration			
Calibration	Off	Amplitude	100%
		Channel	Normal

The input range and resolution change automatically when the gain is selected and the gain in the RESP files and Dataless SEED is updated automatically.

5.12.4 Mass control

The Minimus can lock, unlock and centre the masses of connected instruments.

5.12.4.1 Mass centring

Many broadband seismometers (*e.g.* Güralp 3T and 3ESPC) support remote/electronic mass centring. Change the polarity of the control signal using the drop-down menu if necessary.

Identification			
Sensor type	Generic velocity	Status LED	Idle
Mass Centring			
Centre Mass	Mass Readout Z	-0.00375 V	Mass Readout N
		-0.00312 V	Mass Readout E
		-0.00375 V	
Mass Locking			
Lock Mass	Unlock Mass		
Calibration			
Calibration	Off	Amplitude	100%
		Channel	Normal
Control Polarity			
Mass Lock Polarity	Active Low	Mass Unlock Polarity	Active Low
		Centring Polarity	Active Low
			Active Low
			Active High
Digital Sensors			
Selection			

Mass centring can be controlled from the "Setup" tab of the web page using the **Centre Mass** button. Mass centring status and control can also be found in the Centring tab of the instrument Control Centre window.

5.12.4.2 Mass locking

Some seismometers require their masses to be locked for transportation. Mass locking can be controlled from the "Setup" tab of the web page using the **Lock Mass** and

Güralp Minimus and Minimus+

Unlock Mass buttons. Change the polarity of the control signals using the drop-down menu, if necessary.

Analogue Sensors							
Analogue to Digital Converter							
Input gain	x1.0	Input range	+/- 20.48 V	Input resolution	2.441 uV/count		
Identification							
Sensor type	Generic velocity	Status LED	Idle				
Mass Centring							
Centre Mass	Mass Readout Z	-0.00375 V	Mass Readout N	-0.00312 V	Mass Readout E	-0.00375 V	
Mass Locking							
Lock Mass	Unlock Mass						
Calibration							
Calibration	Off	Amplitude	100%	Channel	Normal		
Control Polarity							
Mass Lock Polarity	Active Low	Mass Unlock Polarity	Active Low	Centring Polarity	Active Low	Cal Enable Polarity	Active Low
Digital Sensors Active Low Active High							
Selection							

Note: The mass lock control buttons are not displayed unless the selected sensor type has a mass-locking mechanism.

5.12.5 Instrument response parameters

Calibration is a procedure used to verify or measure the frequency response and sensitivity of a sensor. It establishes the relationship between actual ground motion and the corresponding output voltage. Calibration values, or response parameters, are the results of such procedures.

Response parameters typically consist of a sensitivity or "gain", measured at some specified frequency, and a set of poles and zeros for the transfer function that expresses the frequency response of the sensor. A full discussion of poles and zeros is beyond the scope of this manual.

The gain for a seismometer is traditionally expressed in volts per ms^{-1} and, for an accelerometer, in volts per ms^{-2} . Other instruments may use different units: an electronic thermometer might characterise its output in mV per $^{\circ}\text{C}$.

A calibration procedure is also used to establish the relationship between the input voltage that a digitiser sees and the output, in counts, that it produces. The results are traditionally expressed in volts per count. Each Minimus is programmed at the factory so that it knows its own calibration values.

Although the Minimus automatically receives calibration parameters from connected digital instruments (*e.g.* Güralp Radian), calibration values need to be entered manually for connected analogue sensors (*e.g.* Güralp Fortis).

To enter the calibration values for your analogue instruments, right-click the Minimus in Discovery's main window and select "Calibration" → "Calibration Editor".

Güralp Minimus and Minimus+

MIN-C555 - Calibration page editor. - Discovery

Instrument 0

Settings

Instrument serial number: TF064

Accelerometer

Component Z Component N Component E Component X Mass Z Mass N Mass E Calibration channel

Parameters

Digitizer Volts per Count (VPC) 2.4398328e-6 V/count

Analogue Instrument Gain 0.52000004 V per ms⁻²

ADC Offset -938.7843 counts

Coil constant nan A/m/s²

Calibration resistor nan Ω

nan

nan

Response

Normalizing factor 1.930001e+9

Poles (Hz)

<input checked="" type="checkbox"/> Pole 0	-755.90002	+ i*	0	Hz
<input checked="" type="checkbox"/> Pole 1	-209.7	+ i*	0	Hz
<input checked="" type="checkbox"/> Pole 2	-63.790001	+ i*	-90.389999	Hz
<input checked="" type="checkbox"/> Pole 3	-63.790001	+ i*	90.389999	Hz
<input type="checkbox"/> Pole 4	nan	+ i*	nan	Hz
<input type="checkbox"/> Pole 5	nan	+ i*	nan	Hz
<input type="checkbox"/> Pole 6	nan	+ i*	nan	Hz
<input type="checkbox"/> Pole 7	nan	+ i*	nan	Hz
<input type="checkbox"/> Pole 8	nan	+ i*	nan	Hz
<input type="checkbox"/> Pole 9	nan	+ i*	nan	Hz
<input type="checkbox"/> Pole 10	nan	+ i*	nan	Hz

Zeros (Hz)

<input type="checkbox"/> Zero 0	nan	+ i*	nan	Hz
<input type="checkbox"/> Zero 1	nan	+ i*	nan	Hz
<input type="checkbox"/> Zero 2	nan	+ i*	nan	Hz
<input type="checkbox"/> Zero 3	nan	+ i*	nan	Hz
<input type="checkbox"/> Zero 4	nan	+ i*	nan	Hz
<input type="checkbox"/> Zero 5	nan	+ i*	nan	Hz

Component configuration

Copy: Poles and Zeros to sensor 0 to component ZNE

Copy

Send axis Z

System calibration values

Poles and Zeros Export to file Import from file

Send instrument calibration to device

Load from device Send to device

Güralp Minimus and Minimus+

This form has one tab for each seismic component, for the mass positions and calibration channel. The instrument's response values should be entered in the here.

These are:

- The **Digitiser Volts per Count (VPC)** – the ratio between the input voltage and the digitised output value (“counts”). This field will be populated automatically with the correct value for this input channel of the Minimus.
- **Analogue Instrument Gain** – this specifies the output voltage of the seismometer per unit of ground motion, as measured at 1 Hertz. This information is normally provided on a calibration document that is shipped with the instrument.
- The **ADC offset** is the quiescent output seen when digitiser input is zero. This field will be populated automatically with the correct value for this input channel of the Minimus.
- The **Coil constant** is the coil constant for the component being calibrated, in A/ms^{-2} , as given on the analogue sensor calibration sheet.
- The **Calibration resistor** is the value of the calibration resistor, in Ω , as given on the sensor calibration sheet. This is common to all sensor components.
- The **Normalising factor** specifies the value that the transfer function (as specified by the poles and zeros) must be multiplied by in order to provide unity gain at 1 Hz.
- The **Poles** and **Zeros** describe the frequency and phase response of the component. They must be specified in Hertz. This information is normally provided on a calibration document that is shipped with the instrument.

The calibration parameters for one component can be copied to any other component of the same instrument, or other instruments. This is especially useful for poles and zeros, because they are typically identical for all three components of all instruments in a class.

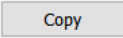
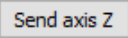
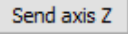
The drop-down menu in the “Component configuration” section allows selection of what to copy: poles and zeros, gains or everything. The destination sensor and component(s) can be selected in the subsequent drop-down menus. Click on the  button to copy and paste the selected values. Finally click on  button to send the calibration values to the digitiser and save them permanently. Repeat this last step for the other axis. Note that  only sends the calibration of the selected axis.

Güralp Minimus and Minimus+

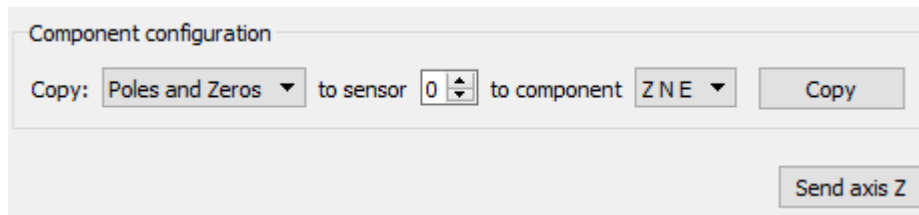

Component configuration

Copy: Poles and Zeros to sensor 0 to component ZNE Copy

Send axis Z

The overall system calibration parameters can be exported and saved in a file for future use by clicking on the **Export to file** button under “System calibration values”.

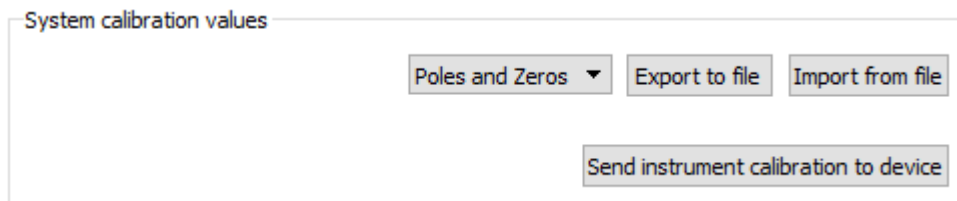

System calibration values

Poles and Zeros Export to file Import from file

Send instrument calibration to device

The resulting file-name will have the extension `.conf`. Values from an existing calibration file can be imported using the **Import from file** button. The associated drop-down menu allows specification of what to import: poles and zeros, gains or everything. Click on **Send instrument calibration to device** to send the calibration values to the digitiser and save them permanently. Note that this action will only send the calibration of the selected sensor. Click on the **Send to device** button to send the complete calibration to the digitiser.

When transmitting MiniSEED data, the responses of the instruments and digitisers are encoded in a message called a “Dataless SEED” volume. The contents of these volumes can be displayed in human-readable form, known as RESP, by clicking on the “RESP file” link of each channel in the “Data Stream” and “Data Record” tab of the Minimus web page.

Güralp Minimus
and Minimus+

Clicking on a RESP file link produces a page like this:

```

#           << Güralp SEED response file builder v1.2-8615 >>
#
#           ===== CHANNEL RESPONSE DATA =====
B050F03   Station:      TEST
B050F16   Network:       DG
B052F03   Location:      OK
B052F04   Channel:       HNZ
B052F22   Start date:   2018,214,11:26:48
B052F23   End date:     No Ending Time
#
#           +-----+
#           +-----+-----+-----+-----+
#           +           | Channel Sensitivity, TEST ch HNZ |           +
#           +-----+-----+-----+-----+
#
B058F03   Stage sequence number:      0
B058F04   Sensitivity:                 2.131148E+05
B058F05   Frequency of sensitivity:    1.000000E+00 HZ
B058F06   Number of calibrations:      0
#
#           +-----+
#           +-----+-----+-----+-----+
#           +           | Response (Poles & Zeros), TEST ch HNZ |           +
#           +-----+-----+-----+-----+
#
B053F03   Transfer function type:      A [Laplace Transform (Rad/sec)]
B053F04   Stage sequence number:      1
B053F05   Response in units lookup:    M/S**2 - Acceleration in Metres Per Second Squared
B053F06   Response out units lookup:   V - Volts
B053F07   A0 normalization factor:    3.022955E+12
B053F08   Normalization frequency:    1.000000E+00
    
```

Right-click anywhere and select "Back" to return to the Minimus web page.

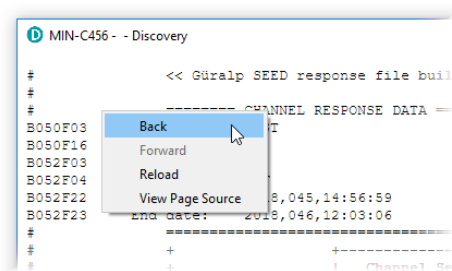

To save a RESP file, right click on it in the main list and select "Save Link":

Güralp Minimus and Minimus+

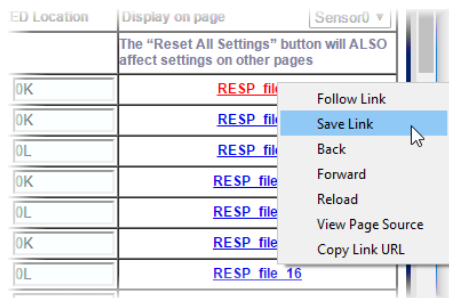

Note: RESP files are not available for channels that have a transform enabled. For details about transforms, see section 5.15 on page **Error! Bookmark not defined..**

5.13 Configuration and control of connected digital instruments

Please refer to MAN-RAD-0001 for full details on configuring and controlling compatible digital instruments, such as the Güralp Radian, connected to the Minimus.

5.14 Setting sensor orientation and depth parameters

5.14.1 Applied rotation

A Matlab extension for Scream! allows easy determination of the exact orientation of a sensor relative to a surface reference sensor (which can be accurately aligned magnetically or geographically). The procedure is explained at <https://www.guralp.com/howtos/determining-sensor-orientation>.

The Relative Orientation extension of Scream! provides a correction angle that can be entered into the Sensor Orientation section of the Setup tab of the Minimus web page.

Digitizer Controls					
<input type="button" value="Reboot"/>		<input type="button" value="Reset All Settings"/>		The "Reset All Settings" button will ALSO affect settings on other pages	
Digitizer Config					
Auto Refresh	<input type="text" value="1"/>	Auto Reboot	<input type="text" value="On Error"/>	Low Latency Mode	<input type="text" value="Balanced"/>
Host Label	<input type="text" value="SPRT-MIN"/>	Station Code	<input type="text" value="TEST"/>	Network Code	<input type="text" value="DG"/>
Bluetooth PIN	<input type="text" value="0000"/>	Bluetooth	<input type="text" value="Enabled"/>	Filter quality	<input type="text" value="High"/>
Deploy Mode	<input type="text" value="Power Save"/>	Auto Center Disable(hr)	<input type="text" value="12"/>	Deploy	<input type="text" value=""/>
Applied Rotation					
Analogue 0	<input type="text" value="0"/>				
Digital 1	<input type="text" value="0"/>	Digital 2	<input type="text" value="0"/>	Digital 3	<input type="text" value="0"/>
Digital 4	<input type="text" value="0"/>	Digital 5	<input type="text" value="0"/>	Digital 6	<input type="text" value="0"/>
Digital 7	<input type="text" value="0"/>	Digital 8	<input type="text" value="0"/>	Digital 9	<input type="text" value="0"/>

This feature can be applied to analogue seismometers and accelerometers and also to Borehole or Post-hole Radians, when installed with a vertical orientation.

Note: The input rotation is automatically applied to both transmitted and recorded data.

5.14.2 Instrument installation parameters

The Dip (tilt angle from vertical), Azimuth (tilt direction from North) and Depth of analogue or digital sensors connected to the Minimus can be set in the Setup tab of the

Güralp Minimus
and Minimus+

web interface in the section “Instrument Installation Parameters”. The instrument to which the displayed parameters apply is selected using the drop-down menu.

Sensor Installation Parameters							
Sensor	Sensor 0	Dip	0	Azimuth	0	Depth	0
Analogue Sensor							
Analogue to Digital Converter							
Input gain	Sensor 0	Input range		Input resolution			
	Sensor 1	+/- 20.48 V		2.441 uV/count			
Identification							
Sensor type	Sensor 2	Status LED	idle				
	Sensor 3						
Mass Centring							
Centre Mass	Sensor 4	Mass Readout Z	-0.00375 V	Mass Readout N	-0.00312 V	Mass Readout E	-0.00375 V
	Sensor 5						
Mass Locking							
Lock Mass	Sensor 6	Unlock Mass					
	Sensor 7						
	Sensor 8						

Note: The orientation and depth are not applied to the data, the parameters are only saved in the Dataless SEED.

5.14.3 Inject a calibration signal

To check whether the analogue sensor(s) connected to the Minimus is correctly calibrated, go to the Setup tab of the web page and use the drop-down menu to choose between Triangle, Square and White Noise signal to be injected into the sensor's feedback loop.

Analogue Sensors							
Analogue to Digital Converter							
Input gain	x1.0	input range	+/- 20.48 V	input resolution	2.441 uV/count		
Identification							
Sensor type	Güralp 3T	Status LED	idle				
Mass Centring							
Centre Mass		Mass Readout Z	-0.00375 V	Mass Readout N	-0.00312 V	Mass Readout E	-0.00375 V
Mass Locking							
Lock Mass		Unlock Mass					
Calibration							
Calibration	Triangle	Amplitude	100%	Channel	Normal		
Digital Sensors							
Selection							
Initialisation							

Adjust the calibration signal amplitude at 100%, 50%, 25% or 12.5% of the DAC full range.

Calibration					
Calibration	Triangle	Amplitude	100%	Channel	Normal
Digital Sensors					
Selection					
Initialisation	complete				

Finally, enable the calibration on all three components of the selected analogue sensor.

Güralp Minimus and Minimus+

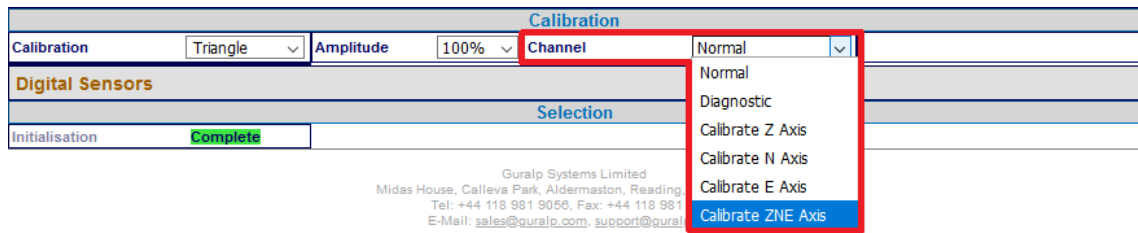

Note: The calibration channel, named nVELC0 (or nACCC0), produces an output if and only if the calibration is in progress.

While the calibration is in progress, the webpage shows the warning message **Calibration in progress** and Discovery flags the status icon in yellow.

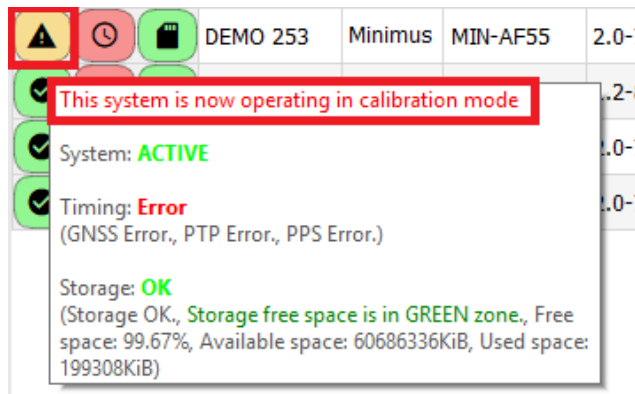

5.15 Transforms

The Minimus is capable of applying mathematical transforms to the streamed and recorded data. These include low-pass and high-pass filters, integration, differentiation, rotation, STA/LTA ratio etc.

When a specific transform is activated on a particular channel, the resulting streamed (or recorded, accordingly to the chosen configuration) data output is automatically transmitted and/or recorded with the transform applied. The units-of-measure are re-calculated accordingly.

Transform functions are enabled or disabled from the “Data Stream” and “Data Record” tabs for each channel.

Note: To enable or disable a transform on any channel, it is necessary to reboot the Minimus. Transforms can be applied only on enabled channels.

Some transforms require parameters such as frequencies or coefficients. For these, the user can either use a fixed, default set, or create their own custom set.

To use customised parameters, visit the “Transform” tab and select the “Saved User Parameters” option in the “Parameter Source” drop-down menu. Type in the required parameters and then click **Save Parameters** to store them. It is possible to switch between Default and Saved User Parameters without altering the stored custom parameters but clicking **Save Parameters** while “Default parameters” is selected will overwrite the customised parameters with the default values.

The various transforms are each described in the following sections following:

Caution: The  button at the top of the "Transform" column does not disable *transforms* for all streams. It stops *transmission* of all streams, which may not be what you intend.

5.15.1 Pass-through

This null transform simply outputs a copy of the input data, without applying any transform. It has no configuration parameters.

Status Network Setup Power Trigger Data Stream Data Record Transforms Storage Logout Help

System type: Minimus | Host label: Support | Host name: MIN-C555 (10.10.0.13) | Serial number: 50517

Data Stream				
Display Streams	All	Transform	Try to NOT change any SEED Location	Display On Page Sensor0
Reboot		Disable All Streams	Reset All Settings	
0XCHN0	200 Hz	Transforms Disabled	<input type="checkbox"/> DG.TEST,00 HDF	RESP file 5
0ACCZ0	200 Hz	Pass-through	<input type="checkbox"/> DG.TEST,00 HHZ	RESP file 7

Status Network Setup Power Trigger Data Stream Transforms Storage Logout Help

System type: Minimus | Host label: Support | Host name: MIN-C555 (10.10.0.13) | Serial number: 50517

Configure Transforms	
0ACCZ0	Pass-through
Selected Transform	Pass-through

Note: This transform is selected by default when transforms are first enabled or when an invalid transform is selected. Do not use pass-through as a method of disabling transforms: instead, select "Disable transforms" from the drop-down menu next to each stream on the "Data Streams" tab,

5.15.2 Differentiation

This transform differentiates the input data, e.g. if the input is a velocity (ms-1) channel, the output will be acceleration (ms-2). It has no configuration parameters.

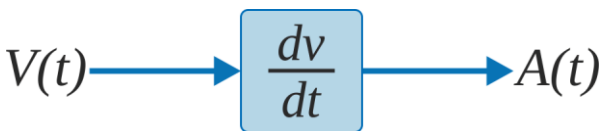

Status Network Setup Power Trigger Data Stream Data Record Transforms Storage Logout Help

System type: Minimus | Host label: Support | Host name: MIN-C555 (10.10.0.13) | Serial number: 50517

Data Stream				
Display Streams	All	Transform	Try to NOT change any SEED Location	Display On Page Sensor0
Reboot		Disable All Streams	Reset All Settings	
0XCHN0	200 Hz	Transforms Disabled	<input type="checkbox"/> DG.TEST,00 HDF	RESP file 5
0ACCZ0	200 Hz	Differentiation	<input type="checkbox"/> DG.TEST,00 HHZ	RESP file 7

Status Network Setup Power Trigger Data Stream Transforms Storage Logout Help

System type: Minimus | Host label: Support | Host name: MIN-C555 (10.10.0.13) | Serial number: 50517

Configure Transforms	
0ACCZ0	Differentiation
Selected Transform	Differentiation

Güralp Minimus and Minimus+

5.15.3 1st order LPF

This transform applies a first-order low-pass filter to the input data.

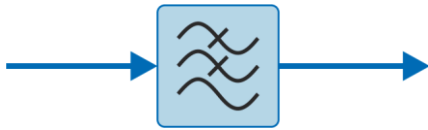

The single configurable parameter is "Corner Frequency": this specifies, in Hz, the frequency at which the output power is attenuated by -3 dB. Above this frequency, output power is attenuated by a further 6 dB per octave or 20 dB per decade.

Status Network Setup Power Trigger **Data Stream** Data Record Transforms Storage Logout Help

System type: Minimus | Host label: Support | Host name: MIN-C555 (10.10.0.13) | Serial number: 50517

Data Stream				
Display Streams	All	Transform	Try to NOT change any SEED Location	Display On Page
				Sensor0
Reboot		Disable All Streams		Reset All Settings
The "Reset All Settings" button will ALSO affect settings on other pages				
0XCHN0	200 Hz	Transforms Disabled	<input type="checkbox"/> DG.TEST:00	HDF
RESP file 5				
0ACCZ0	200 Hz	1st Order LPF	<input type="checkbox"/> DG.TEST:00	HHZ
RESP file 7				

Status Network Setup Power Trigger Data Stream Data Record **Transforms** Storage Logout Help

System type: Minimus | Host label: Support | Host name: MIN-C555 (10.10.0.13) | Serial number: 50517

Configure Transforms			
OVELZ0			
Selected Transform	1st Order LPF	Parameter Source	Default Parameters
Corner Frequency (Hz)		10	Save Parameters

5.15.4 1st Order HPF

This transform applies a first-order high pass filter to the input data.



The output is the difference between a low-pass filtered copy of the signal and the unfiltered signal.

The single configurable parameter is "Corner Frequency": this specifies, in Hz, the frequency at which the output power is attenuated by -3 dB. Below this frequency, output power is attenuated by a further 6 dB per octave or 20 dB per decade.

Note: The high-pass filter is implemented by subtracting the output of a low-pass filter from the unfiltered data:



Güralp Minimus and Minimus+

Status Network Setup Power Trigger **Data Stream** Data Record Transforms Storage Logout Help

System type: Minimus | Host label: Support | Host name: MIN-C555 (10.10.0.13) | Serial number: 50517

Data Stream				
Display Streams	All	Transform	Try to NOT change any SEED Location	Display On Page
Reboot		Disable All Streams		Reset All Settings
0XCHN0	200 Hz	Transforms Disabled	<input type="checkbox"/> DG.TEST.00 HDF	RESP file 5
0ACCZ0	200 Hz	1st Order HPF	<input type="checkbox"/> DG.TEST.00 HHZ	RESP file 7

Status Network Setup Power Trigger Data Stream Data Record **Transforms** Storage Logout Help

System type: Minimus | Host label: Support | Host name: MIN-C555 (10.10.0.13) | Serial number: 50517

Configure Transforms				
OVELZ0				
Selected Transform	1st Order HPF	Parameter Source	Default Parameters	Save Parameters
Corner Frequency (Hz)	10			

5.15.5 1st Order Band/Notch filter

This transform applies first-order band stop or Notch filter to the input data.



The band-stop filter is implemented as a configurable chain of two components:

A 1st order high pass filter (implemented using an LPF and a subtractor, as described in Section 5.15.4 on page **Error! Bookmark not defined.**), to gradually attenuate low-frequency integrator drift.

A 1st order low pass filter (implemented as described in Section 5.15.3 on page **Error! Bookmark not defined.**).

The configurable parameters are the "High Pass Frequency" (HPF corner frequency as defined in Section 5.15.4 on page **Error! Bookmark not defined.**) and the "Low Pass Frequency" (LPF corner frequency as defined in Section 5.15.3 on page **Error! Bookmark not defined.**).

Status Network Setup Power Trigger **Data Stream** Data Record Transforms Storage Logout Help

System type: Minimus | Host label: Support | Host name: MIN-C555 (10.10.0.13) | Serial number: 50517

Data Stream				
Display Streams	All	Transform	Try to NOT change any SEED Location	Display On Page
Reboot		Disable All Streams		Reset All Settings
0XCHN0	200 Hz	Transforms Disabled	<input type="checkbox"/> DG.TEST.00 HDF	RESP file 5
0ACCZ0	200 Hz	Band/Notch Filter (1st Order)	<input type="checkbox"/> DG.TEST.00 HHZ	RESP file 7

Status Network Setup Power Trigger Data Stream Data Record **Transforms** Storage Logout Help

System type: Minimus | Host label: Support | Host name: MIN-C555 (10.10.0.13) | Serial number: 50517

Configure Transforms				
OVELZ0				
Selected Transform	Band/Notch Filter (1st Order)	Parameter Source	Default Parameters	Save Parameters
High Pass Frequency (Hz)	0.1	Low Pass Frequency (Hz)	50	

Güralp Minimus and Minimus+

5.15.6 2nd Order biquad

This transform applies a second-order bi-quadratic filter to the input data.

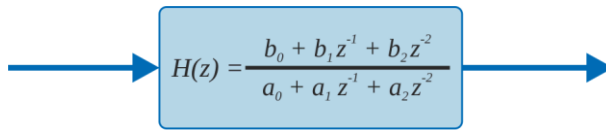

The biquad filter is a second-order recursive linear filter, containing two poles and two zeros. In the Z-plane, the transfer function is the ratio of two quadratics in z, as shown.

The two configurable parameters are:

"Corner Frequency": this specifies, in Hertz, the frequency at which the output power is attenuated by -3 dB; and

"Type":

0: low-pass mode; and

1: high-pass mode.

System type: Minimus | Host label: Support | Host name: MIN-C555 (10.10.0.13) | Serial number: 50517

Data Stream			
Display Streams	All	Transform	Try to NOT change any SEED Location
Reboot		Disable All Streams	Reset All Settings
0XCHN0	200 Hz	Transforms Disabled	<input type="checkbox"/> DG.TEST,00 .HDF
0ACCZ0	200 Hz	2nd Order Biquad	<input type="checkbox"/> DG.TEST,00 .HHZ

Status Network Setup Power Trigger Data Stream Data Record **Transforms** Storage Logout Help

System type: Minimus | Host label: Support | Host name: MIN-C555 (10.10.0.13) | Serial number: 50517

Configure Transforms			
0ACCZ0			
Selected Transform	2nd Order Biquad		Parameter Source
Type (HPF/LPF)	0	Corner Frequency (Hz)	10
0 = Low Pass Filter, 1 = High Pass Filter			

5.15.7 Integration

This transform integrates the input data, e.g. if the selected channel unit is velocity (ms⁻¹), the output produced is displacement (m).

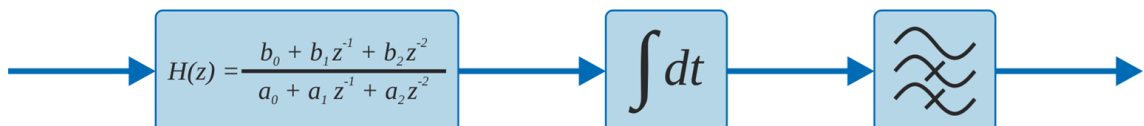

The integration transform is implemented as a configurable chain of three components:

A DC filter (2nd order high-pass bi-quadratic) removes any DC component, which would cause the output to grow without limit;

The integrator itself; and

Güralp Minimus
and Minimus+

A 1st order high pass filter (implemented using an LPF and a sub-tractor, as described in Section 5.15.4 on page **Error! Bookmark not defined.**), to gradually attenuate low-frequency integrator drift.

The configurable parameters are:

"DC Cut-off Frequency": this specifies the -3 dB point (in Hertz) for the initial high-pass filter;

"Output Cut-off Frequency": this specifies the -3 dB point (in Hertz) for the output high-pass filter;

"Configuration Mode", which configures how many elements of the chain are used. The options are:

Apply only the initial DC filter;

Apply the DC filter and the integrator; and

Apply the DC filter, the integrator and the output HPF.

The image shows two screenshots of the Minimus web interface. The top screenshot is the 'Data Stream' page, which displays a table of data streams. The bottom screenshot is the 'Configure Transforms' page for the '0ACCZ0' stream, showing configuration parameters for the 'Integration' transform.

Display Streams	transform	Try to NOT change any SEED Location	Display On Page
0XCHN0	200 Hz	Transforms Disabled	Sensor0
0ACCZ0	200 Hz	Integration	

Configure Transforms			
0ACCZ0			
Selected Transform	Integration	Parameter Source	Default Parameters
DC Cut-off Frequency	0.5	Output Cut-off Frequency	0.003
Configuration Mode	2		

Legend:
 0 = DC filter output
 1 = DC HPF + Integration
 2 = DC HPF + Integration + HPF

5.15.8 Double Integration

This transform integrates the input data twice so, for example, if the selected channel is acceleration (ms-2), the output produced is displacement (m).

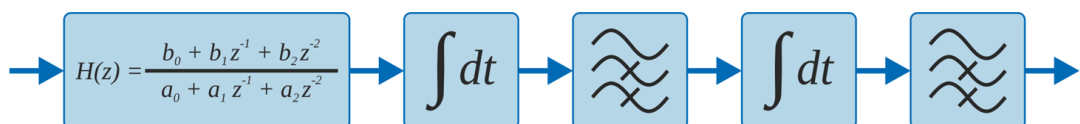

Analogously to the single integrator, the double integrator applies an initial DC high-pass filter and then two further high-pass filters, one at the output of each integrator. The high-pass filters are implemented using an LPF and a subtractor

The configurable parameters are:

Güralp Minimus and Minimus+

"DC Cut-off Frequency": this specifies the -3 dB point (in Hertz) for the initial high-pass filter;

"Interstage Cut-off Frequency": this specifies the -3 dB point (in Hertz) for the first integrator output high-pass filter;

"Output Cut-off Frequency": this specifies the -3 dB (in Hertz) point for the second integrator output high-pass filter;

"Configuration Mode", which configures how many elements of the chain are used. The options are:

Apply only the initial DC filter;

Apply DC filter and first integrator;

Apply DC filter, first integrator and interstage HPF;

Apply DC filter, first integrator, interstage HPF and second integrator; and

Apply DC filter, first integrator, interstage HPF, second integrator and second output HPF.

The image shows two screenshots of the Minimus web interface. The top screenshot is the 'Data Stream' page, and the bottom screenshot is the 'Configure Transforms' page.

Data Stream Page:

- Navigation: Status, Network, Setup, Power, Trigger, **Data Stream**, Data Record, Transforms, Storage, Logout, Help
- System info: System type: Minimus | Host label: Support | Host name: MIN-C555 (10.10.0.13) | Serial number: 50517
- Section: **Data Stream**
- Display Streams: All (dropdown), Transform: Try to NOT change any SEED Location, Display On Page: Sensor0 (dropdown)
- Buttons: Reboot, Disable All Streams, Reset All Settings
- Table:

Stream	Filter	Transform	Options	Link
0XCHN0	200 Hz	Transforms Disabled	<input type="checkbox"/> DG.TEST,00 .HDF	RESP file 5
0ACCZ0	200 Hz	Double Integration	<input type="checkbox"/> DG.TEST,00 .HHZ	RESP file 7

Configure Transforms Page:

- Navigation: Status, Network, Setup, Power, Trigger, **Data Stream**, Data Record, **Transforms**, Storage, Logout, Help
- System info: System type: Minimus | Host label: Support | Host name: MIN-C555 (10.10.0.13) | Serial number: 50517
- Section: **Configure Transforms**
- Selected Transform: **0ACCZ0**
- Table:

Parameter	Value	Parameter	Value	Parameter	Value
DC Cut-off Frequency	0.5	Interstage Cut-off Frequency	0.003	Output Cut-off Frequency	0.0015
Parameter Source	Default Parameters	Configuration Mode	4	Save Parameters	[Button]

Legend:

- 0 = DC filter output
- 1 = DC HPF + 1st integration
- 2 = DC HPF + 1st integration + HPF
- 3 = ... + 2nd integration
- 4 = ... + 2nd integration + HPF

5.15.9 EEW Parameters – Observer

When an EEW trigger occurs (or is simulated – see below), the peak ground motion values (Peak Ground Acceleration (PGA), Peak Ground Velocity (PGV) and Peak Ground Displacement (PGD)) are calculated and automatically recorded over the selected time-window and subsequently transmitted as a CAP message (see Section 5.16 on page **Error! Bookmark not defined.** for more details). This transform allows the operator to directly observe the acceleration, velocity and displacement output on the real-time streams. It is available for use with both velocity and acceleration input signals.

Note: The EEW parameter transform can work as an observer: doesn't necessarily modify the data streams on which it is applied.

The implementation of the transform differs, depending on whether the input stream represents velocity or acceleration data.

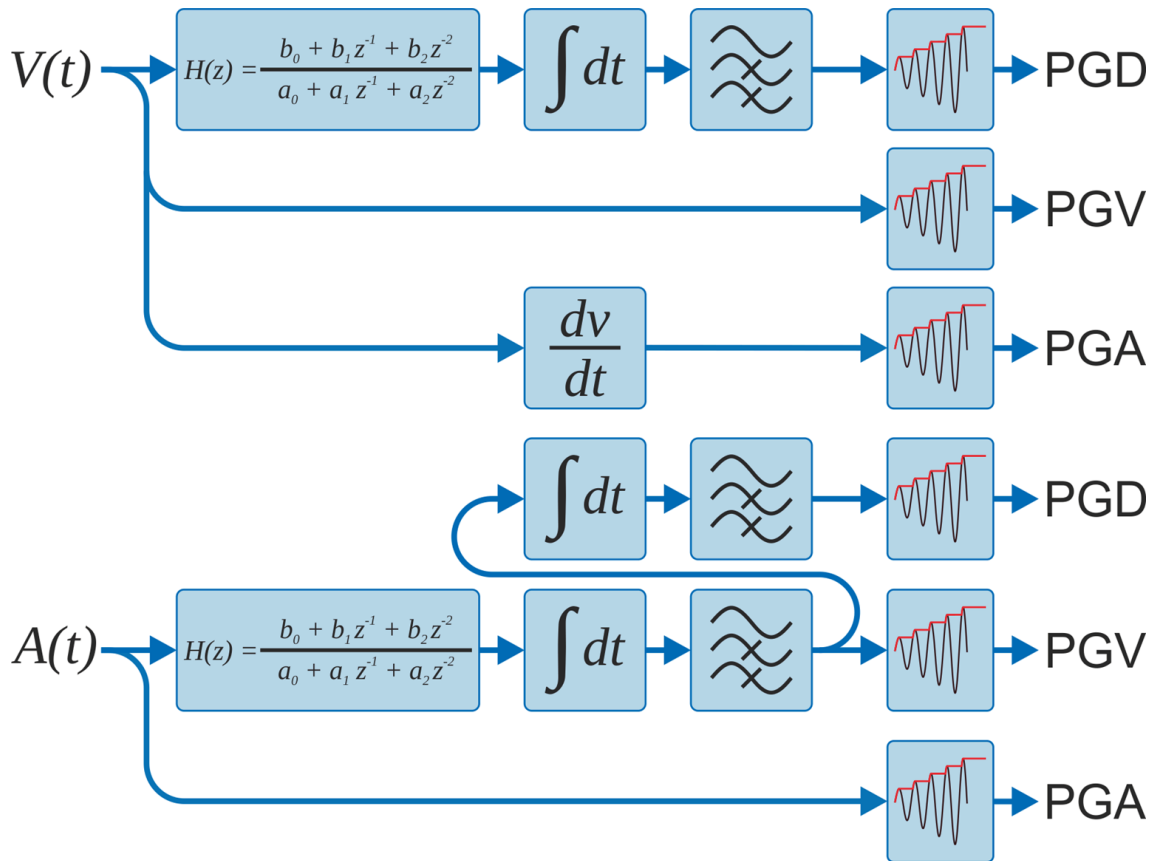

The high-pass filters are implemented using an LPF and a subtractor, as described in Section 5.15.4 on page **Error! Bookmark not defined.**

The configurable parameters are:

- "DC Cut-off Frequency": this specifies the -3 dB point (in Hertz) for the initial high-pass filter;
- "Interstage Cut-off Frequency": this specifies the -3 dB point (in Hertz) for the first integrator output high-pass filter. This is only used when the input signal is acceleration;
- "Output Cut-off Frequency": this specifies the -3 dB (in Hertz) point for the sole (velocity input) or final (acceleration input) integrator output high-pass filter;
- "Window time": this specifies the duration, in seconds, of the time-window over which the peak values are reported;

Güralp Minimus and Minimus+

- “Preview Mode”: the values to be shown in the output stream:
 - unmodified original stream (acceleration or velocity);
 - acceleration;
 - velocity; or
 - displacement.

Note: Güralp recommend using the integration (section 5.15.7 on page **Error! Bookmark not defined.**) and double integration (section 5.15.8 on page **Error! Bookmark not defined.**) transforms to test the filter parameters, because the effect of the parameters will then be clearly visible in the transformed streams. Once suitable parameters have been determined, they can be copied to the EEW Parameter - Observer transform.

The screenshot shows the Minimus web interface. The top navigation bar includes: Status, Network, Setup, Power, Trigger, **Data Stream**, Data Record, Transforms, Storage, Logout, Help.

System type: Minimus | Host label: Support | Host name: MIN-C555 (10.10.0.13) | Serial number: 50517

Data Stream

Display Streams	All	Transform	Try to NOT change any SEED Location	Display On Page	Sensor0
Reboot		Disable All Streams		Reset All Settings	
0XCHN0	200 Hz	Transforms Disabled	<input type="checkbox"/> DG.TEST.00	HDF	RESP file 5
0ACCZ0	200 Hz	EEW Parameters Observer	<input type="checkbox"/> DG.TEST.00	HHZ	RESP file 7

The “Reset All Settings” button will ALSO affect settings on other pages

Navigation: Status, Network, Setup, Power, Trigger, **Data Stream**, Data Record, **Transforms**, Storage, Logout, Help

System type: Minimus | Host label: NO LABEL | Host name: MIN-C555 (10.10.0.10) | Serial number: 00C555

Configure Transforms

Selected Transform: **0ACCZ0**

EEW Parameters - Observer | Parameter Source: Default Parameters | Save Parameters

DC Cut-off Frequency	0.5	Interstage Cut-off Frequency	0.003	Output Cut-off Frequency	0.0015	Window Time (seconds)	3
Preview Mode	0						

0 = No preview
 1 = View acceleration in stream
 2 = View velocity in stream
 3 = View displacement in stream.

5.15.10 STA/LTA Ratio

The Earthquake Early Warning system (EEW) compares the ratio of a short-term average (STA) to a long-term average (LTA) in order to detect "trigger" conditions. For more information see Section 5.16 on page **Error! Bookmark not defined.**

This transform is included to help determine parameters for configuring the EEW system. It does not affect the operation of the EEW system in any way. The transform calculates the ratio between the result of the Short Term Average filter and the Long Term Average filter. The input signal is passed through a high-pass filter which removes any DC offset.



The configurable parameters are:

"DC Frequency (Hz)": this specifies the corner frequency (-3 dB point) in Hertz for the initial high-pass filter;

"LTA Period (seconds)": this is the Short Term Average filter time period (the reciprocal of the corner frequency);

"STA Period (seconds)": this is the Long Term Average filter time period (the reciprocal of the corner frequency);

"Trigger Threshold": this is the STA/LTA ratio threshold value above which a trigger will occur;

"Event Window (Seconds)": this is the duration of the event after the STA/LTA trigger occurs; any subsequent threshold crossing within this period is treated as belonging to the same event. This can be used to avoid spurious false triggers.

"Initial Timeout (Seconds)": this specifies an initial period of insensitivity after the trigger function is initialised or changed. This can be used to avoid spurious false triggers.

The high-pass filter is implemented using an LPF and a subtracter, as described in Section 5.15.4 on page **Error! Bookmark not defined.**

Status Network Setup Power Trigger Data Stream Data Record Transforms Storage Logout Help

System type: Minimus | Host label: SUPRT-MIN | Host name: MIN-C555 (10.10.0.13) | Serial number: 50517

Data Stream					
Display Streams	All	Transform	Try to NOT change any SCCD Location		Display On Page
Reboot		Disable All Streams		Reset All Settings	
0AUX0	200 Hz	Transforms Disabled	<input type="checkbox"/> DG.TEST00	HDF HDF	RESP file 5
0ACC0	200 Hz	STA/LTA Ratio	<input type="checkbox"/> DG.TEST00	HHZ HNZ	RESP file 7

Status Network Setup Power Trigger Data Stream Transforms Storage Logout Help

System type: Minimus | Host label: SUPRT-MIN | Host name: MIN-C555 (10.10.0.13) | Serial number: 50517

Configure Transforms					
0ACC0					
Selected Transform		STA/LTA Ratio		Parameter Source	
		Default Parameters		Save Parameters	
DC coefficient	0.001	LTA coefficient	0.005	STA coefficient	0.1

5.15.11 Three-dimensional Rotation

This transform rotates three velocity/acceleration seismic components in space. Rotations are represented by unit quaternions (in preference to the more usual Euler angles: yaw, pitch and roll) because they are unambiguous and avoid the problem of gimbal lock.

Note: The rotation transform can only be applied if it is enabled in all three velocity/acceleration components of a single instrument at the same sample rate.

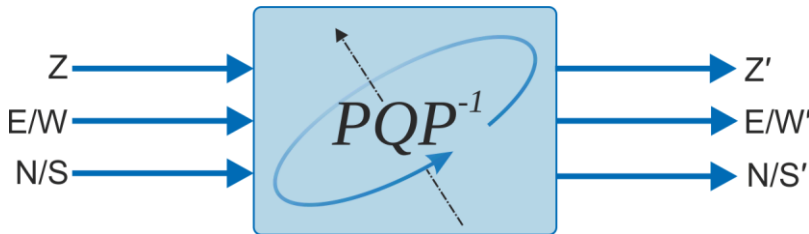

Any rotation in three dimensional space can be represented as a combination of a unit three-dimensional vector, \vec{u} , which specifies the axis (and sense) of the rotation, and a scalar angle, θ , which specifies the amount of rotation

Güralp follows a North, East, Up convention when describing sensor orientation. Using this convention, we can represent \vec{u} as $[u,v,w]$ and use Pauli's extension to Euler's formula:



to form a quaternion: where:



For example, a perfectly- oriented sensor has a (null) rotation of , where the sensor's Z, N and E axes align with the North, East and Up global axes.

A rotation of



represents a sensor that has been rotated 90° about its x axis to align the sensor's Z, N and E axes with global North, Down and East respectively.



Note: Clockwise rotations, when looking along an axis, are denoted as positive. This is generally known as the "right-hand rule" because, if you point your right thumb along the (directed) axis, your fingers will curl in a clockwise direction about it.

In the degenerate case of a simple rotation about a vertical axis (commonly used to correct data from a misaligned borehole instrument), the axis of rotation is vertical, so

Güralp Minimus
and Minimus+

our unit vector is [0,0,1] (following the "North, East, Up" convention). To rotate by θ (where positive θ is clockwise when looking upwards), our quaternion should be:



As a final check, note that



which satisfies our requirement for a unit quaternion. The parameters to enter in the Configure Transforms fields are, therefore:

Scalar \Rightarrow ~~1~~, **X** \Rightarrow 0, **Y** \Rightarrow 0 and **Z** \Rightarrow ~~1~~

Status Network Setup Power Trigger **Data Stream** Data Record Transforms Storage Logout Help

System type: Minimus | Host label: Support | Host name: MIN-C555 (10.10.0.13) | Serial number: 50517

Data Stream					
Display Streams	All	Transform	try to NOT change any SEED Location	Display On Page	Sensor0
Reboot		Disable All Streams		Reset All Settings	
0AUXX0	200 Hz	Transforms Disabled	<input type="checkbox"/> DG.TEST,00	HDF	RESP file 5
0ACCZ0	200 Hz	Rotation (Triplet)	<input type="checkbox"/> DG.TEST,00	HDF	RESP file 7
0ACCN0	200 Hz	Rotation (Triplet)	<input type="checkbox"/> DG.TEST,00	HDF	RESP file 8
0ACC0	200 Hz	Rotation (Triplet)	<input type="checkbox"/> DG.TEST,00	HDF	RESP file 11

Status Network Setup Power Trigger Data Stream **Transforms** Data Record Storage Logout Help

System type: Minimus | Host label: Support | Host name: MIN-C555 (10.10.0.13) | Serial number: 50517

Configure Transforms					
0ACCZ0 / 0ACCN0 / 0ACC0					
Selected Transform	Rotation (Triplet)		Parameter Source	Default Parameters	Save Parameters
Scalar	1	X	0	Y	0
				Z	0

5.15.12 QSCD Sender (triplet)

The QSCD protocol (Quick Seismic Characteristic Data) transmits values computed from the three triaxial streams of an instrument. One packet is transmitted every second so the number of samples in each packet is equal to the sample rate of the three input streams.

QSCD calculations are implemented using transforms and configured via the Data Stream tab of the Minimus web page. The three input channels must all be configured with the QSCD (triplet) transform. (The transform is disabled if the sample rates of the input streams do not match.)

Güralp Minimus and Minimus+

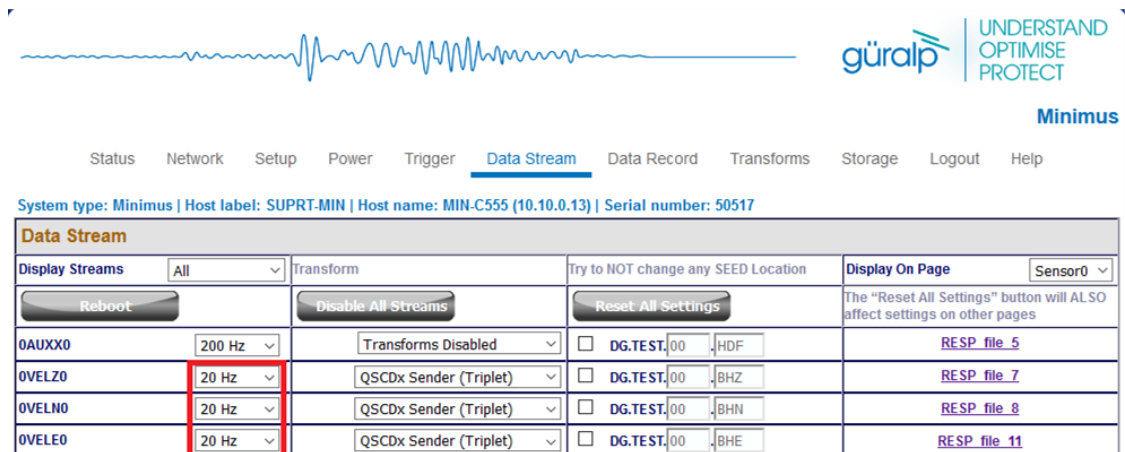

güralp | UNDERSTAND OPTIMISE PROTECT

Minimus

Status Network Setup Power Trigger **Data Stream** Data Record Transforms Storage Logout Help

System type: Minimus | Host label: SUPRT-MIN | Host name: MIN-C555 (10.10.0.13) | Serial number: 50517

Display Streams	Transform	Try to NOT change any SEED Location	Display On Page
0AUXX0	200 Hz	Transforms Disabled	<input type="checkbox"/> DG.TEST.00 HDF RESP file 5
0VELZ0	20 Hz	QSCDx Sender (Triplet)	<input type="checkbox"/> DG.TEST.00 BHZ RESP file 7
0VELN0	20 Hz	QSCDx Sender (Triplet)	<input type="checkbox"/> DG.TEST.00 BHN RESP file 8
0VELE0	20 Hz	QSCDx Sender (Triplet)	<input type="checkbox"/> DG.TEST.00 BHE RESP file 11

In the Transform tab, the parameter “Period length” configures the number of samples to include in a QSCD packet. For example, QSCD20 requires the sample rate of the streams to be 20 sps so the “Period length” must be set to 20 (samples), in order to send a packet every second.

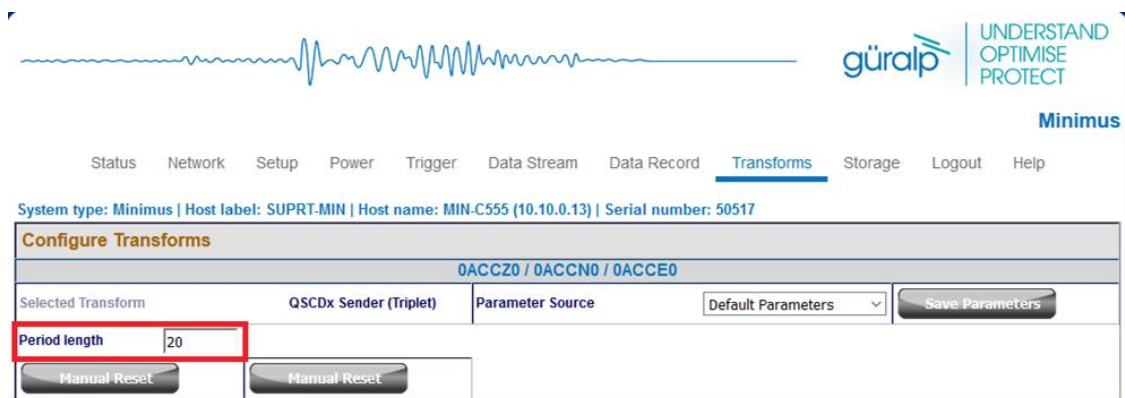

güralp | UNDERSTAND OPTIMISE PROTECT

Minimus

Status Network Setup Power Trigger Data Stream Data Record **Transforms** Storage Logout Help

System type: Minimus | Host label: SUPRT-MIN | Host name: MIN-C555 (10.10.0.13) | Serial number: 50517

Configure Transforms

0ACCZ0 / 0ACCN0 / 0ACC00

Selected Transform: QSCDx Sender (Triplet) | Parameter Source: Default Parameters | Save Parameters

Period length: 20

Manual Reset Manual Reset

5.15.13 MMA Logger

The MMA logger transform is a function that periodically calculates and logs Maximum Minimum and mean (Average) values over a selected window of data.

Note: The EEW parameter transform is an observer: doesn't modify the data streams on which it is applied.

The two configurable parameters are:

“Short Period Length”: this is the length of time between logging events expressed in samples, e.g. 200 samples when applied to a tap configured at 100sps produces an MMA calculation and logging every 2 seconds.

“Window Length in Short Periods”: is the length of window over which the Max, Min and Average values are calculated, in terms of number of short periods.

Güralp Minimus and Minimus+

Status Network Setup Power Trigger **Data Stream** Data Record Transforms Storage Logout Help

System type: Minimus | Host label: SUPRT-MIN | Host name: MIN-C555 (10.10.0.13) | Serial number: 50517

Data Stream

Display Streams	All	Transform	Try to NOT change any SCEED Location	Display On Page	Sensur0
Reboot		Disable All Streams		Reset All Settings	
The "Reset All Settings" button will ALSO affect settings on other pages					
0AUXX0	200 Hz	Transforms Disabled	<input type="checkbox"/>	DG.TEST,00	HDF HDF
0ACCZ0	200 Hz	MMA Logger	<input type="checkbox"/>	DG.TEST,00	HHZ HNZ
				RESP file 5	
				RESP file 7	

Status Network Setup Power Trigger Data Stream **Transforms** Storage Logout Help

System type: Minimus | Host label: SUPRT-MIN | Host name: MIN-C555 (10.10.0.13) | Serial number: 50517

Configure Transforms

0ACCZ0

Selected Transform	MMA Logger	Parameter Source	Default Parameters	Save Parameters
Short Period Length	1000	Window Length in Short Periods	5	

5.16 Earthquake Early Warning

The "Trigger" tab is dedicated to Earthquake Early Warning settings. These are disabled by default because of the amount of processing resource – and hence, power – consumed by triggering calculations.

The Triggers section of the web page enables the user to configure the triggering system. The trigger Sources should be configured firstly because different configuration options are displayed for different source types. Once the source-specific settings are configured, the scores and destinations should be specified. Destinations can be shared between sources, allowing the creation of networks (directed graphs) of systems for distributed event detection.

The heart of the Earthquake Early Warning subsystem are the triggering algorithms: an STA/LTA (Short-Time-Average divided by Long-Time-Average) and level (threshold) algorithms.

The STA/LTA algorithm continuously calculates the average values of the absolute amplitude of a seismic signal in two simultaneous moving-time windows. The short time average (STA) is sensitive to seismic events while the long time average (LTA) provides information about the current amplitude of seismic background noise at the site. When the ratio of STA to LTA exceeds a pre-set threshold value an event is "declared".

The threshold algorithm, instead, declares the presence of an event when the raw data in input passes above or below a pre-set threshold value.

5.16.1 Trigger sources

The available sources for the trigger are listed below, along with the configurable fields available in each case.

- **1st/2nd/3rd/4th Remote Source:** This setting is used for multiple-source triggering networks. The sources specified here are other Minimus digitisers

or Minimus based instruments, specified by the I.P. addresses configured in the “Remote Inputs” section:

Triggers configuration					
Source	1st Remote Source	Score	100	Destination	Disabled

The configurable fields in these cases are:

- **Score:** this assigns a number of points to this trigger. The points value is used when assessing multiple-source triggers. This value is ignored when a trigger is not configured to use multiple sources.
- **Destination:** this drop-down menu specifies the destination for the trigger. See Section 5.16.2 on page **Error! Bookmark not defined.** for more information.
- **n^{th} Address:** is the I.P. address of the remote source, *e.g.* another Minimus.

Sources	
Remote Inputs	
1st Address	

- **1st/2nd/3rd/4th I/O Expander Input:** Select this value to use inputs from a connected Minimus 8 channel I/O Expander Module.

Triggers configuration					
Source	1st I/O Expander Input	Score	100	Destination	Disabled

The configurable fields in these cases are:

- **Score:** this assigns a number of points to this trigger. The points value is used when assessing multiple-source triggers. This value is ignored when a trigger is not configured to use multiple sources.
- **Destination:** this drop-down menu specifies the destination for the trigger. See Section 5.16.2 on page **Error! Bookmark not defined.** for more information.
- **Tap Trigger N :** seismic or environmental Minimus channels selectable among any of the active taps in the “Data Stream” and “Data Record” tabs.

Triggers configuration					
Source	Tap Trigger A [0ACC20]	Score	100	Destination	Disabled

The configurable fields in these cases are:

- **Score:** this assigns a number of points to this trigger. The points value is used when assessing multiple-source triggers. This value is ignored when a trigger is not configured to use multiple sources.

- Destination: this drop-down menu specifies the destination for the trigger. See Section 5.16.2 on page **Error! Bookmark not defined.** for more information.
- Sensor number: this drop-down menu selects what sensor's streams to use as input of the trigger algorithm.
- Tap: this drop-down menu select the stream to use as input of the trigger algorithm. The choice is between single taps, *e.g. OVELZO*, or triplets, *e.g. First Seismo Triplet*.
- Trigger type: this drop-down menu chooses to use either STA/LTA or threshold algorithm.

The STA/LTA trigger algorithms includes the configuration of the following parameters:

Sources			
Remote Inputs			
Tap Triggers			
Tap Trigger A	Sensor 0	0ACCZ0	STA/LTA Trigger
DC Frequency (Hz)	0.04	LTA Period (Seconds)	12
		STA Period (Seconds)	0.5
Event Window (Seconds)	5	Initial Timeout (Seconds)	10
		<input type="checkbox"/> Preview in Stream	
		Trigger Threshold	12

- "DC Frequency": initial AC coupling HPF corner frequency;
- "LTA Period": Long Term Average filter time period (1/corner frequency);
- "STA Period": Short Term Average filter time period (1/corner frequency);
- "Trigger Threshold": STA/LTA ratio level at which trigger occurs;
- "Event Window": After and even has been detected, subsequent crossing of the STA/LTA ratio threshold within the defined event window are treated as part of the same event and, therefore, not considered as new trigger event;
- "Initial Timeout": period of inactivity after the trigger function is initialised in order to avoid false triggers.

The threshold trigger algorithms includes the configuration of the following parameters:

Sources			
Remote Inputs			
Tap Triggers			
Tap Trigger A	Sensor 0	0ACCZ0	Threshold Trigger
Absolute Mode	0	Low/High Mode	1
		Threshold	10
Hysteresis Percentage	10	Timeout	10
		<input type="checkbox"/> Preview in Stream	

- “Absolute Mode”: specifies if the threshold has to act on magnitude with sign (0) or absolute value of the signal (1).
- “Low/High Mode”: defines whether the threshold is exceeded when the signal passes below it (0) or above it (1);
- “Threshold”: value of the threshold expressed in native signal unit, *e.g.* m/s²;
- “Timeout”: specifies the time to wait (in seconds), after the threshold crossing, before accepting a new event;
- “Hysteresis Percentage”: defines the hysteresis point in terms of percentage of threshold value below or above threshold. The hysteresis point is below the threshold for High Mode, above the threshold for Low Mode.
- The “Preview in Stream” box temporally shows the in the live streams the output calculated by the trigger algorithm, *e.g.* the STA/LTA ratio. In the STA/LTA ratio trigger, when a single stream is selected as source, the calculated STA/LTA ratio is shown in place of the original data.

Note: Only STA/LTA ratio has preview on single streams, both Threshold and STA/LTA ratio have preview of triplets.

When a triplet is selected as source, “3D or Z & NE” parameters is used to choose what type of preview to visualise.

For STA/LTA ratio trigger algorithm:

Sources			
Local Tap Triggers			
Tap Trigger A	Sensor 0	First Seismo Triplet	STA/LTA Trigger
DC Frequency (Hz)	0,04	LTA Period (Seconds)	12
Event Window (Seconds)	5	Initial Timeout (Seconds)	10
		3D or Z & NE	1
		STA Period (Seconds)	0,5
		Trigger Threshold	12
		<input checked="" type="checkbox"/> Preview in Stream	

1 = Trigger off of the 3D resultant of Z, N & E together.
0 = Trigger off of the Z component and the 2D resultant of the horizontal N & E components separately.

- 0: shows STA/LTA ratio calculated on 2D resultant vector of N and E components. The 2D STA/LTA ratio is shown in place of original E/W component. Also, shows the STA/LTA ratio calculated on Z component and it is shown in place of original Z component. N/S component shows normal seismic output.
- 1: shows STA/LTA ratio calculated on 3D resultant vector of Z, N and E components. The STA/LTA ratio is shown on E/W component. Z and N/S components show normal seismic output.

Güralp Minimus
and Minimus+

For Threshold trigger algorithm:

Sources				
Local Tap Triggers				
Tap Trigger A		Sensor 0	First Seismo Triplet	Threshold Trigger
Absolute Mode	0	Low/High Mode	1	Threshold 10 Timeout 10
Hysteresis Percentage	10	3D or Z & NE	1	<input checked="" type="checkbox"/> Preview in Stream

1 = Trigger off of the 3D resultant of Z, N & E together.
0 = Trigger off of the Z component and the 2D resultant of the horizontal N & E components separately.

- 0: shows the 2D resultant vector of N and E components. The 2D resultant is shown in place of E/W component. Z and N/S components show normal seismic output.
- 1: shows the 3D resultant vector of Z, N and E components. 3D resultant is shown in place of E/W component. Z and N/S components show normal seismic output.

5.16.2 Trigger destinations

The options available from the various Destination fields are:

- 1st/2nd/3rd/4th CAP receiver:** When a trigger is declared, the system will issue messages using the Common Alerting Protocol (for the full specification of this protocol, please refer to <http://docs.oasis-open.org/emergency/cap/v1.2/CAP-v1.2-os.html>).

This field selects to which of the four available CAP receivers the trigger information should be sent to.

Triggers configuration				
Source	1st Remote Source	Score	100	Destination 1st CAP receiver

Destinations				
Common Alerting Protocol Messaging				
1st CAP Address	52.34.40.123	1st CAP Port	11789	Total Score 300 1st CAP Threshold 200
1st CAP Msg scope	Restricted	1st CAP Recipient	eeew@guralp.com	1st CAP Inhibit Timeout 10 1st CAP Acceptance Window 1

Various parameters control how the CAP message is created:

- n^{th} CAP Address: the I.P. address or DNS name of the CAP receiver;
- n^{th} CAP Port: the UDP port on which the CAP receiver is listening;
- Total Score: this is an information field, it displays an automatically-calculated total of the scores from all of the input sources that specify this destination;
- n^{th} CAP Threshold: this threshold is used when multiple input sources contribute to this trigger. Otherwise trigger threshold from source configuration is used.

Güralp Minimus
and Minimus+

- n^{th} CAP Msg scope: this value is copied to the “scope” field of the CAP message;
- n^{th} CAP Recipient: this value is copied to the “addresses” field of the CAP message;
- n^{th} CAP Inhibit Timeout: is the time the Minimus waits before sending new CAP message if a new event is detected after a previous CAP message was sent;
- n^{th} CAP Acceptance Window: subsequent source triggers for a given destination are counted towards the cumulative score if they arrive within this window;

Common Alerting Protocol			
CAP Msg Expiry	<input type="text" value="300"/> seconds	CAP Msg Web URL	<input type="text" value="https://cap-validator.appspot.com"/>
CAP Msg HMAC Key		<input type="text" value="secret"/>	

- CAP Msg Expiry: this parameter determines the value used to populate the optional “expires” field in the CAP message. If required, it should be specified in seconds.
- CAP Msg Web URL: this parameter determines the value used to populate the optional “web” field in the CAP message. It should be a full, absolute URI for an HTML page or other text resource with additional or reference information regarding this alert.
- CAP Msg HMAC Key: a shared key used for signing the CAP message. All CAP messages generated by Minimus are signed. The user should set this key to a private value. The HMAC digest can then be used to both authenticate the sender and validate the contents of CAP messages by anyone who is privy to the shared key. This prevents the generation of false, malicious CAP messages by a third party.

EEW parameters (PGA, PGV and PGD values) are sent in the CAP messages body if and only if the “EEW parameter – Observer” transform is enabled on the source taps (see Section 5.15.9 on page **Error! Bookmark not defined.**).

- **1st-8th I/O Expander Output:** Select this value to use outputs from a connected Minimus 8 channel I/O Expander Module. See MAN-MIN-1001 for more details.

Triggers configuration			
Source	<input type="text" value="Tap Trigger A [0VELZ0]"/> ▾	Score	<input type="text" value="100"/>
Destination		<input type="text" value="1st I/O Expander Output"/> ▾	

Destinations			
Relay Outputs			
1st Hold Time	<input type="text" value="1"/>	1st Total Score	<input type="text" value="300"/>
1st Inhibit Timeout	<input type="text" value="10"/>	1st Acceptance Window	<input type="text" value="1"/>
		1st Score Threshold	<input type="text" value="200"/>

Various parameters control how the I/O Expander behaves:

- n^{th} Hold Time: is the relay switch timeout in seconds. If configured to 0, no timeout is used, otherwise relay will be released after specified number of seconds;
- n^{th} Total Score: this is an information field, it displays an automatically-calculated total of the scores from all of the input sources that specify this destination;
- n^{th} Score Threshold: this threshold is used when multiple input sources contribute to this trigger. Otherwise trigger threshold from source configuration is used;
- n^{th} Inhibit Timeout: is the time the Minimus waits before sending new command to the I/O Expander if a new event is detected after a previous command was sent;
- n^{th} Acceptance Window: subsequent source triggers for a given destination are counted towards the cumulative score if they arrive within this window.
- 1st/2nd/3rd/4th Remote Source: This setting is used for multiple-destination triggering networks. The destinations specified here are other Minimus digitisers or Minimus based instruments, specified by the I.P. addresses configured in the “Remote Outputs” section:

Triggers configuration			
Source	Tap Trigger A [0VELZ0] ▾	Score	100
		Destination	1st Remote receiver ▾

Destinations			
Remote Outputs			
1st Address		1st Total Score	300
		1st Score Threshold	0
		1st Inhibit Timeout	10
1st Acceptance Window	1		

- n^{th} Address: the I.P. address of the remote Minimus;
- n^{th} Total Score: this is an information field, it displays an automatically-calculated total of the scores from all of the input sources that specify this destination;

- n^{th} Score Threshold: this threshold is used when multiple input sources contribute to this trigger. Otherwise trigger threshold from source configuration is used.
- n^{th} CAP Inhibit Timeout: is the time the Minimus waits before sending new message if a new event is detected after a previous message was sent;
- n^{th} Acceptance Window: subsequent source triggers for a given destination are counted towards the cumulative score if they arrive within this window.

5.16.3 Low Latency Mode

In the “Setup” tab, the “Low Latency Mode” drop-down menu controls the processor workload that affects the power-consumption of the Minimus. This control can be used to prioritise power-consumption at the expense of latency, to balance the two or to optimise latency regardless of the power consumption. Three settings are available:

- Minimum Power \Rightarrow slow processing / higher latency;
- Balanced \Rightarrow optimal;
- Minimum latency \Rightarrow fast processing / lower latency.

The screenshot shows the Minimus web interface. At the top right, there is a logo for 'güralp' and the text 'UNDERSTAND OPTIMISE PROTECT'. Below the logo, the word 'Minimus' is displayed. The navigation bar includes 'Status', 'Network', 'Setup' (which is the active tab), 'Trigger', 'Data Stream', 'Data Record', 'Transform Parameters', 'Storage', 'Logout', and 'Help'. Below the navigation bar, the system information is shown: 'System type: Minimus | Host label: SPRT-MIN | Host name: MIN-C555 (10.10.0.10) | Serial number: 00C555'. The main content area is divided into two sections: 'Digitizer Controls' and 'Digitizer Config'. The 'Digitizer Controls' section has a 'Reboot' button and a 'Reset All Settings' button. The 'Digitizer Config' section contains several configuration fields: 'Auto Refresh' (1), 'Auto Reboot' (On Error), 'Low Latency Mode' (Balanced), 'Host Label' (SPRT-MIN), 'Station Code' (TEST), 'Network Code', 'Bluetooth PIN' (0000), 'Bluetooth' (Enabled), 'Filter quality', 'Deploy Mode' (Normal), and 'Deploy'. The 'Low Latency Mode' dropdown menu is highlighted with a red box, showing three options: 'Balanced', 'Minimum Power', and 'Minimum Latency'.

5.16.4 CAP Receiver

Güralp Discovery includes a CAP (Common Alerting Protocol) receiver. It listens on a specified UDP port for incoming CAP messages. When one arrives, it is displayed and

Güralp Minimus and Minimus+

plotted on a map. In addition, the receiver can open a TCP connection to the cloud-based registry server and display CAP messages that have been sent to the registry server. See Section 5.17 on page **Error! Bookmark not defined.** for information about configuring a registry server.

All CAP messages can be stored in a log-file. The full message is recorded so that it can be re-loaded later, if required. The CAP receiver functionality is accessed using the context (right-click) menu in Discovery or clicking on “Edit” in the menu bar:

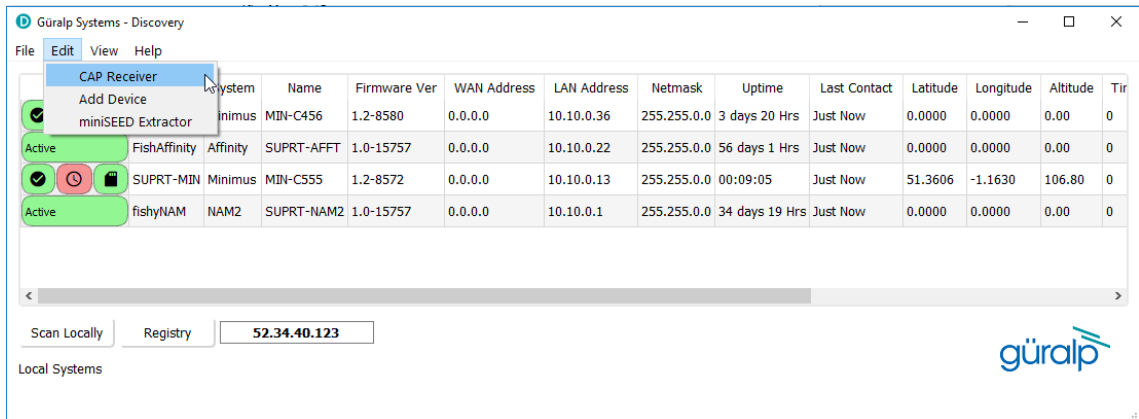

The CAP receiver window allows specification of the listening port. Each Minimus from which messages should be received must have this value specified as the “CAP Port” in its triggering settings (see Section 5.16.2 on page **Error! Bookmark not defined.**). The value should be between 1025 and 65535. You should avoid numbers in the list at https://en.wikipedia.org/wiki/List_of_TCP_and_UDP_port_numbers.

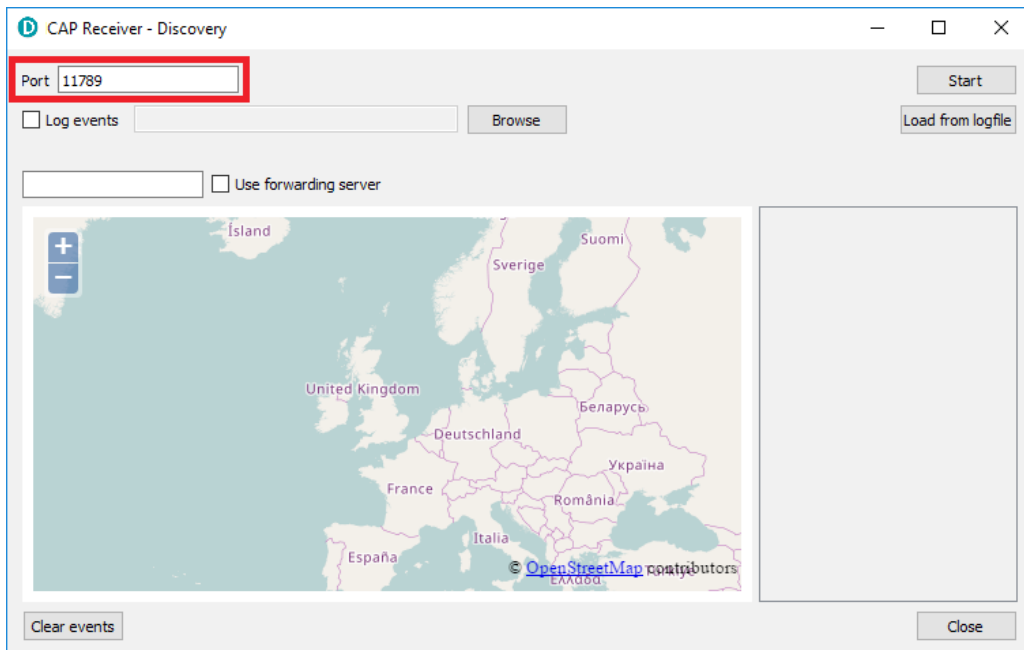

Güralp Minimus and Minimus+

The reception of CAP messages can be enabled or disabled clicking on the **Start** button at the top, right-hand side of the window.

If you wish to forward the CAP messages to a server, type its I.P. address into the field and tick the check-box named “Use forwarding server”. An error message is displayed if the entered I.P. address is not valid.

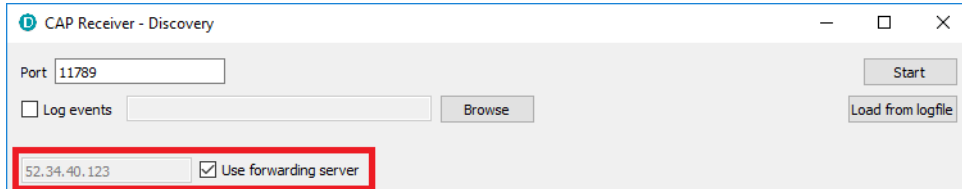

To log CAP messages to a file, tick the “Log events” check-box and use the **Browse** button to select an appropriate location for the database file.

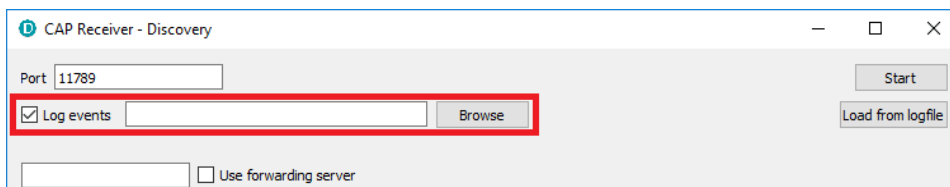

To import an existing database of events, first enable logging, then browse to the file using the **Browse** button and, finally, click the **Load from logfile** button to load the file. If no file is specified, the logging is automatically switched off and a pop-up message is displayed.

Güralp Minimus and Minimus+

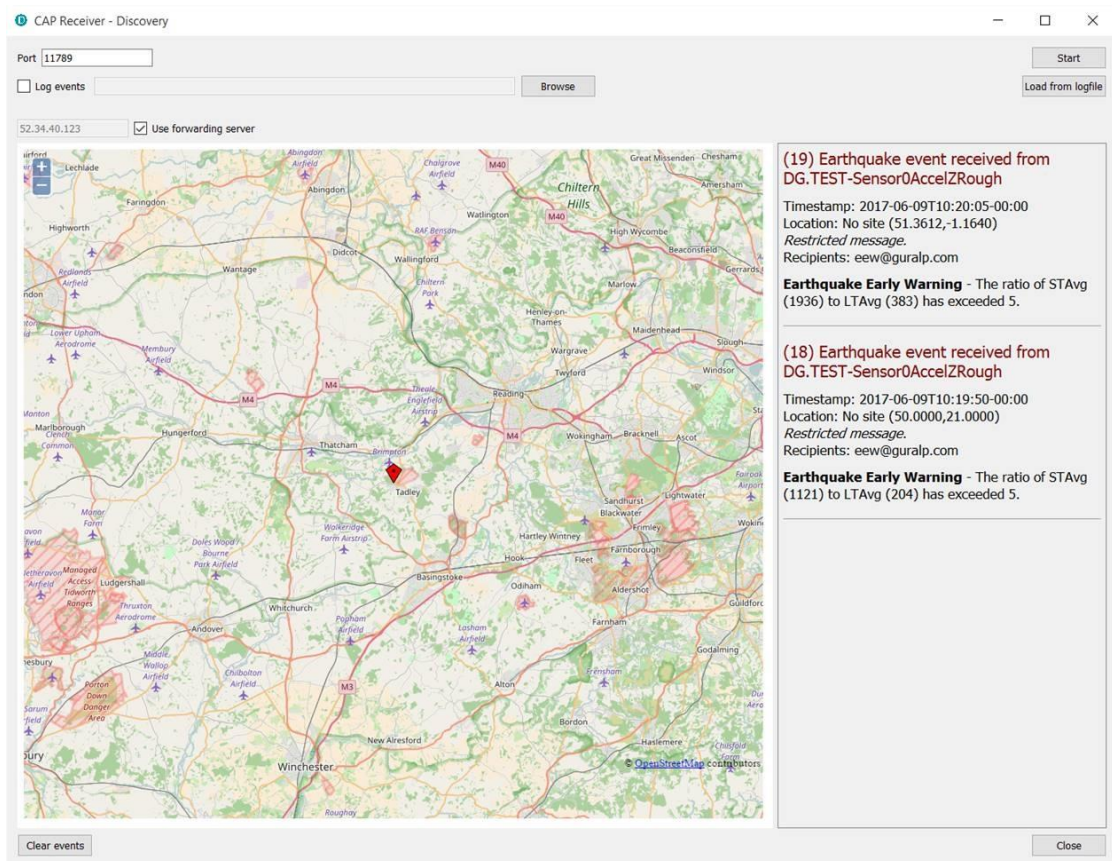

When an event is detected and a CAP message is received, the location of the Minimus that generated the trigger is identified by a pointer displayed on the map. The events and the information contained in the CAP message are displayed at the right-hand side of the window. This includes the SEED identifiers, network, station, channel and location, along with the time, the recipients and the threshold value which was exceeded.

If the EEW parameters are enabled in a particular source, after the first CAP message containing the event information, three other messages with the PGA/PGV/PGD details are sent, one for each component.

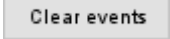
Click on the  button to clear markers from the map and descriptions from the right-hand-side list. This action does not affect the contents of the log-file.

5.16.5 Seismic Event Table

The Minimus can generate a “Seismic Event Table”. This is list of events detected by the STA/LTA or threshold trigger enabled on taps. It contains information about the time when the event occurred, its duration, the channel that generated the trigger and the peak magnitude of the event. The seismic data before, during and after the event are saved in miniSEED format and can be downloaded using links in the table.

The table is located at the bottom of the “Trigger” tab in the Minimus web page.

Güralp Minimus
and Minimus+

Seismic Events Table			
Download Settings:	Seconds Pre	10	Seconds Post
			10
			<input checked="" type="checkbox"/> Download Z,N,E Triplet
Time of Event Duration	Trigger Function (Tap) Peak Magnitude (Time)	Download Source Tap	Download
Thu Aug 2 12:21:17 2018 < 1 second	STA/LTA Trigger (0AXL10) 0.50187 m.s	S0AccZA	Request Event Data
Thu Aug 2 12:21:17 2018 < 1 second	STA/LTA Trigger (0AXL10) 0.58626 m.s	S0AccZA	Request Event Data
Thu Aug 2 12:21:17 2018 < 1 second	STA/LTA Trigger (0AXL10) 0.27047 m.s	S0AccZA	Request Event Data
Thu Aug 2 12:20:46 2018 < 1 second	STA/LTA Trigger (0AXL20) 0.08352 m.s	S0AccNA	Request Event Data
Thu Aug 2 12:20:46 2018 < 1 second	STA/LTA Trigger (0AXL10) 0.74786 m.s	S0AccZA	Request Event Data
Thu Aug 2 12:20:46 2018 < 1 second	STA/LTA Trigger (0AXL20) 0.14463 m.s	S0AccNA	Request Event Data
Wed Aug 1 09:27:20 2018 < 1 second	STA/LTA Trigger (0AXL20) 0.2666 m.s	S0AccNA	Request Event Data

The Minimus allows the download of event data in miniSEED format in a time range that is user selectable. The user can select how many seconds before and after the event detection to include in the miniSEED file.

Download Settings:	Seconds Pre	10	Seconds Post	10	<input checked="" type="checkbox"/> Download Z,N,E Triplet
--------------------	-------------	----	--------------	----	--

Note: Use the  button in the Storage tab to copy most recent data into the microSD cards (see section 5.8.3 on page **Error! Bookmark not defined.**).

The event table shows which of the components has caused the trigger and the user can chose to either download data related to that single component by deselecting the option "Download Z, N, E Triplet" or download data for all three components by leaving the option enabled.

Download Settings:	Seconds Pre	10	Seconds Post	10	<input checked="" type="checkbox"/> Download Z,N,E Triplet
--------------------	-------------	----	--------------	----	--

The last column of the table contains links to downloaded and saved miniSEED files related to each event.

Time of Event Duration	Trigger Function (Tap) Peak Magnitude (Time)	Download Source Tap	Download
Thu Aug 2 12:21:17 2018 < 1 second	STA/LTA Trigger (0AXL10) 0.50187 m.s	S0AccZA	Request Event Data
Thu Aug 2 12:21:17 2018 < 1 second	STA/LTA Trigger (0AXL10) 0.58626 m.s	S0AccZA	Request Event Data
Thu Aug 2 12:21:17 2018 < 1 second	STA/LTA Trigger (0AXL10) 0.27047 m.s	S0AccZA	Request Event Data
Thu Aug 2 12:20:46 2018 < 1 second	STA/LTA Trigger (0AXL20) 0.08352 m.s	S0AccNA	Request Event Data
Thu Aug 2 12:20:46 2018 < 1 second	STA/LTA Trigger (0AXL10) 0.74786 m.s	S0AccZA	Request Event Data
Thu Aug 2 12:20:46 2018 < 1 second	STA/LTA Trigger (0AXL20) 0.14463 m.s	S0AccNA	Request Event Data
Wed Aug 1 09:27:20 2018 < 1 second	STA/LTA Trigger (0AXL20) 0.2666 m.s	S0AccNA	Request Event Data

Note: The links produce downloadable miniSEED files if and only if the requested data is available in the microSD card. This depends on last flushing time and selected post event time.

5.17 Using a Registry

Discovery can maintain a list of Minimus digitisers in a local or cloud-based registry, simplifying management of medium to large networks and removing the need for static I.P. addresses at telemetered stations. Registered digitisers appear in the selection list in the main screen, regardless of whether they are on the local network or not.

Administrators can create their own registry servers by installing a simple program on a server (contact support@guralp.com for more details). The server itself must have a static I.P. address and be accessible to all connected Minimus units, as well as the PCs running discovery. Registry servers programs are currently available for Linux and Windows. Please contact Güralp technical support for details.

For administrators not wishing to install their own registry, Güralp provide a shared registry server in the cloud at 52.34.40.123 which customers are welcome to use.

Registered digitisers must be assigned to groups, each of which has a **Group Identifier**. Instances of Discovery must also be configured with a Group ID and can only display registered digitisers from the matching group. This allows partitioning of large networks into smaller administrative domains. It also makes possible the simultaneous use of the Güralp shared registry server by multiple organisations.

To use a registry:

Choose whether to use the Güralp shared registry or to deploy your own. If deploying your own, install the software on your chosen server and note its public I.P. address.

Choose one or more Group IDs for your digitisers.

Set the Registry server address and Group ID in each Minimus.

Set the Registry server address and Group ID in each instance of Discovery.

Configuring a Minimus for use with a registry

The address of the registry server and the chosen Group ID must be set individually for each participating Minimus digitiser.

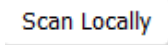
To do this, first connect the Minimus to the same network as a PC running Discovery and click the  button, so that the Minimus appears in the main Discovery

list. Right-click () on the digitiser's entry and select "View Web Page" from the context menu:

Güralp Minimus and Minimus+

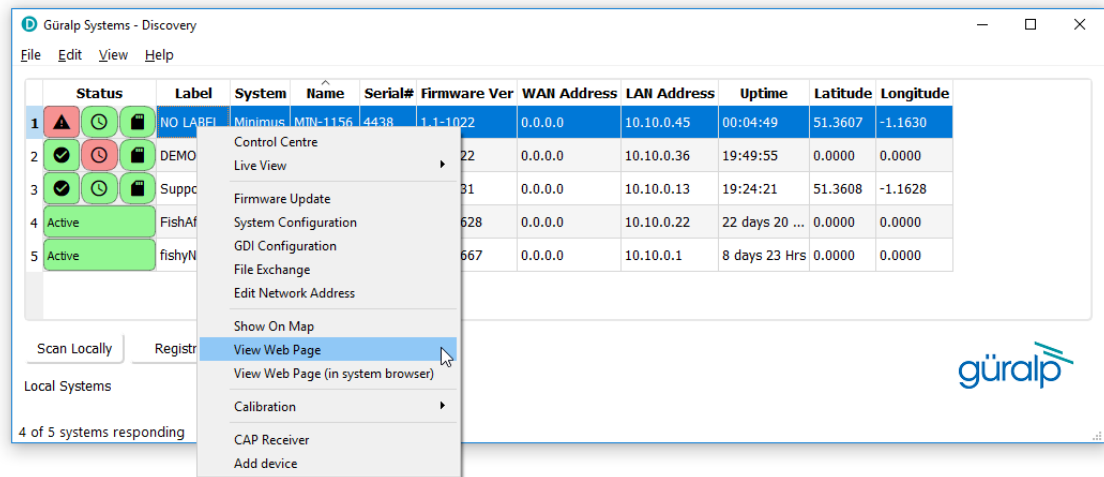

In the resulting web page, select the “Network” tab. The Registry parameters can be found near the bottom of the resulting screen:

Registry					
Registry Update	Every 10Secs ▾	Group ID	NothernArray	Registry Address	52.34.40.123

These are:

- **Registry Update:** the frequency at which the registry is updated with details of this digitiser can be specified here, using the drop-down menu;
- **Group ID:** the chosen Group Identifier should be entered here;
- **Registry Address:** the I.P. address of the registry should be entered here. To use the Güralp shared cloud server, enter 52 . 34 . 40 . 123.

Once you have set the correct values, the digitiser must be rebooted before they will take effect. To do this, click the  button.

5.17.1 Configuring Discovery for use with a registry

To specify a registry server for an instance of discovery, type its address into the field at the bottom left of the main screen:

Güralp Minimus and Minimus+

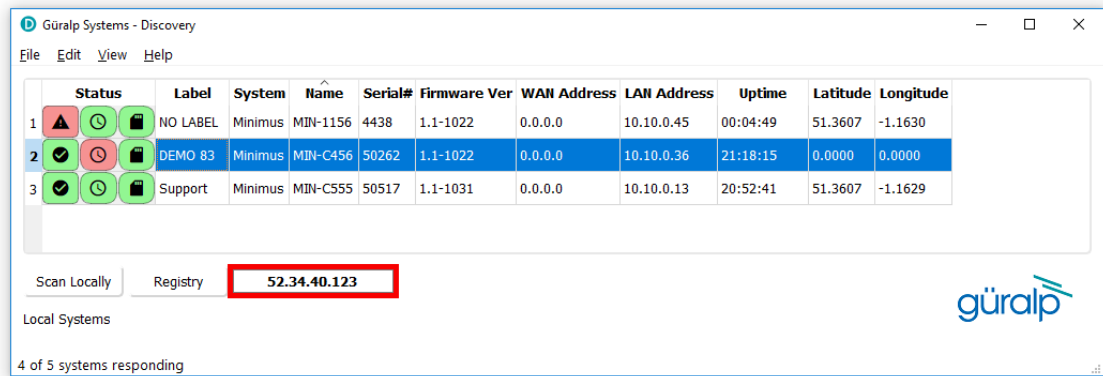

To set the Group ID in Discovery:

1. Select "Settings " from the "File" menu:

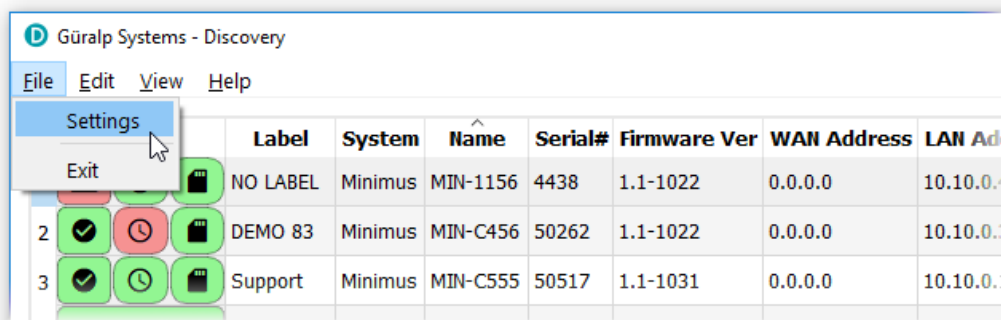

2. Type the chosen Group ID in the "Cloud registry group identifier" field and click **Apply**.

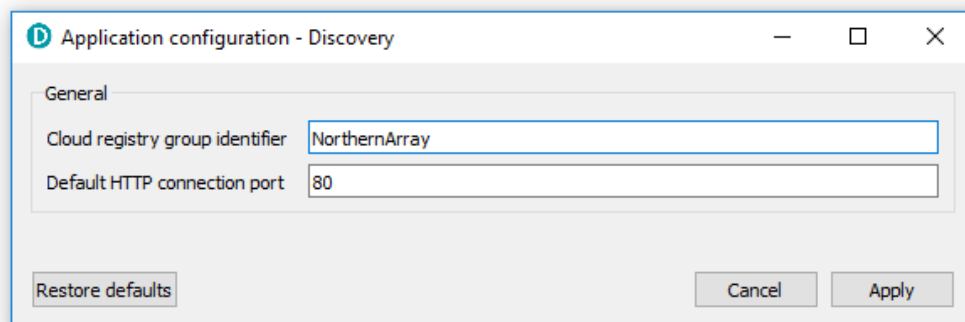

Return to the main windows and test the configuration by clicking the **Registry** button. All Minimus digitisers using the same Registry server and Group ID should appear in the main list.

5.17.2 Registry mode: using WAN or LAN addresses

When Discovery displays a list of devices found from a local scan, all access to those systems is initiated via the LAN address. When displaying a list of registered devices, you have the option of using either the LAN address or the WAN address. This can be

Güralp Minimus and Minimus+

useful when the WAN address has been configured but is not yet available or when a registered device is installed remotely and not available on the LAN. The feature is controlled by exactly where you right-click in the list of devices.

If you right-click anywhere other than in the LAN address column, the WAN address is used and the behaviour is otherwise exactly as previously documented. To access the digitiser via its LAN address, right-click in the LAN address column, as shown below:

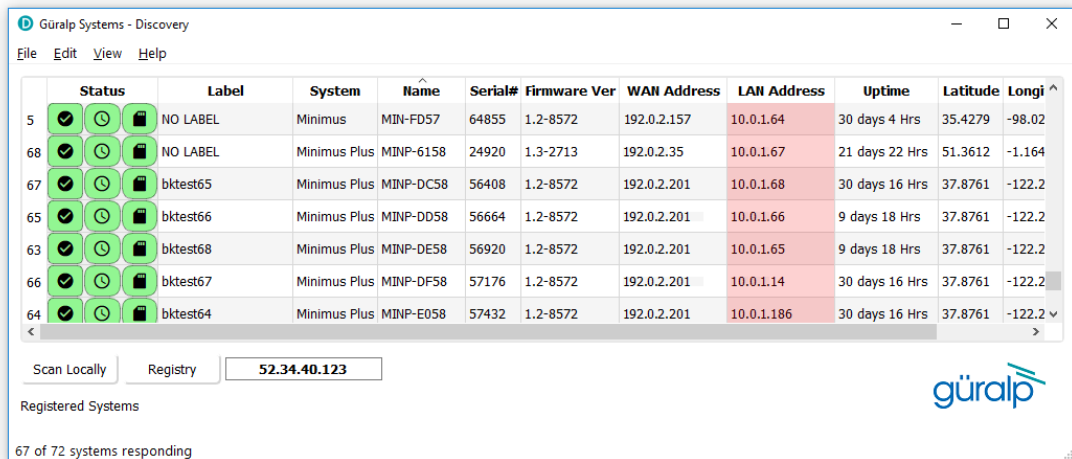

When you click on the LAN address of an entry, the context menu changes:

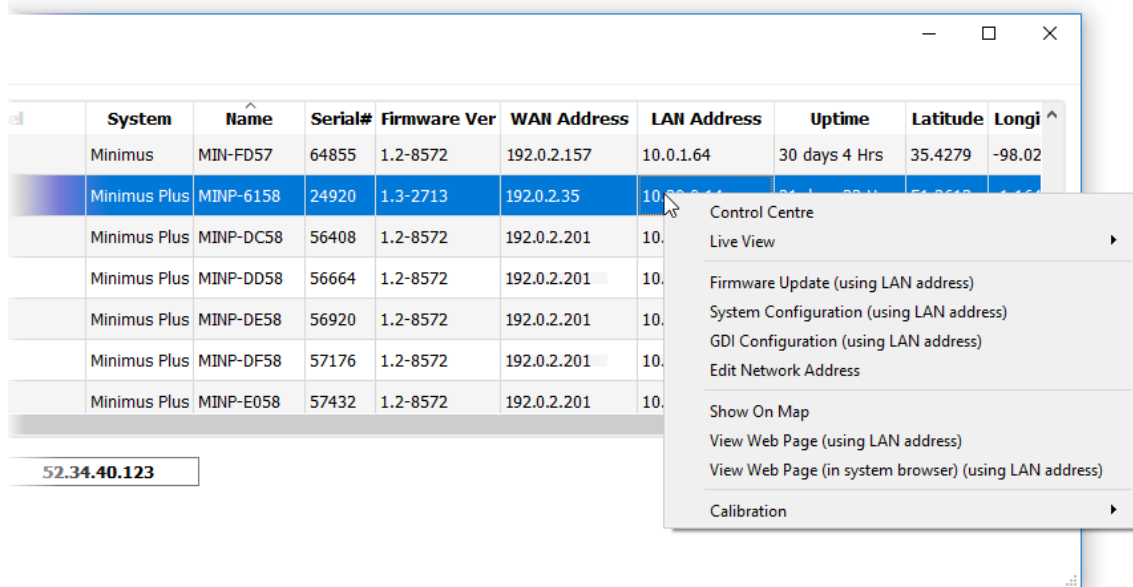

Entries for firmware updates, system and GDI configuration and web page access all now use the LAN address rather than the WAN address.

In addition, all options on the Live View sub-menu use the LAN address:

Güralp Minimus and Minimus+

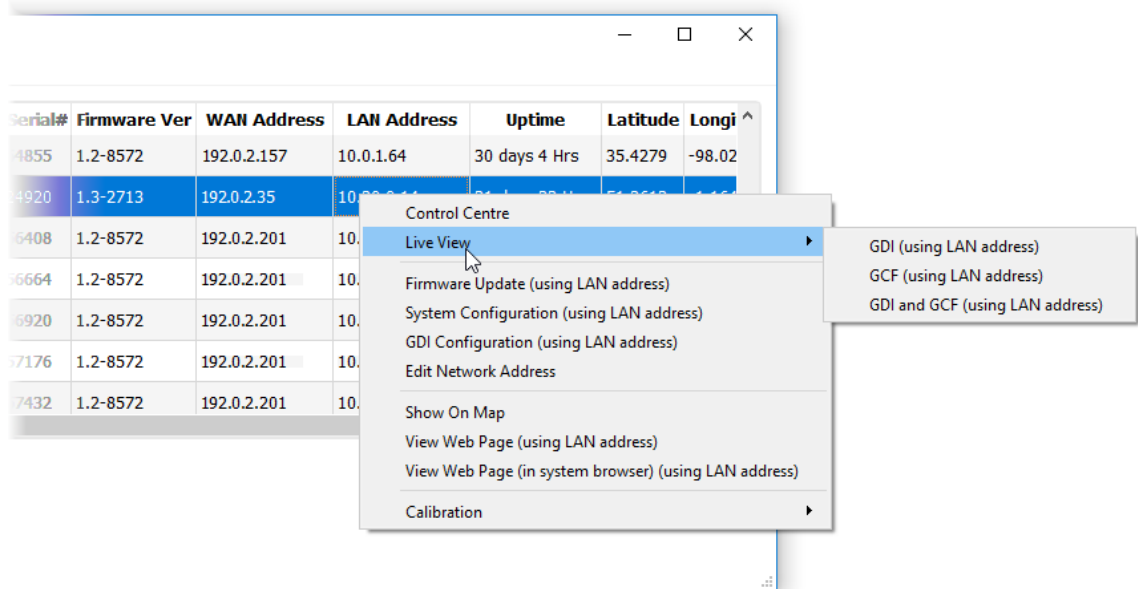

and the calibration page editor is also invoked using the LAN address:

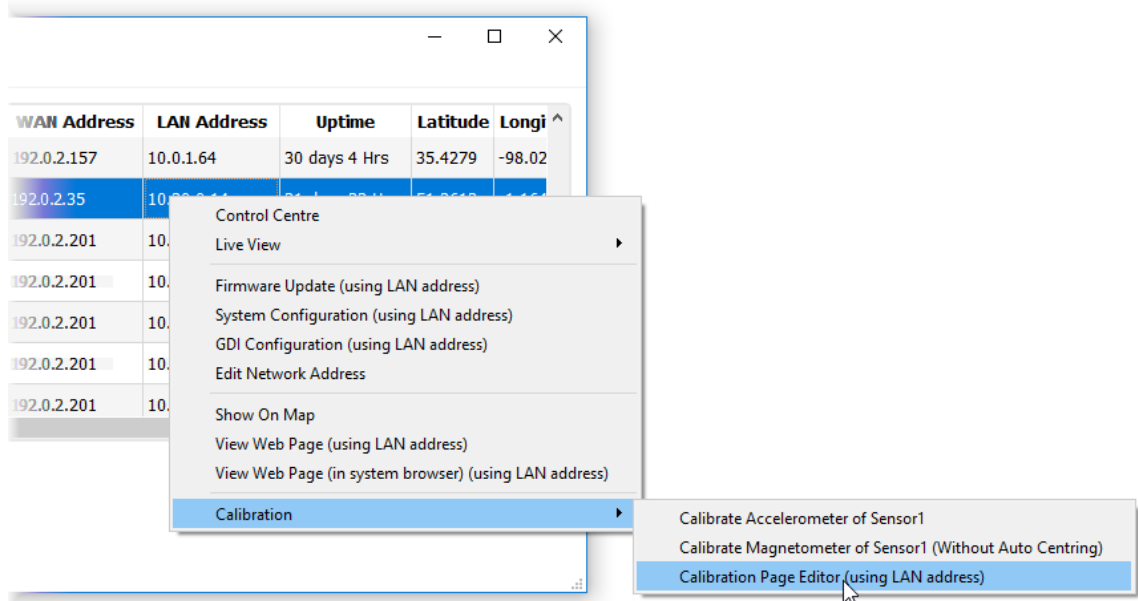

For these techniques to work, the digitiser and PC must be connected to the same LAN.

5.18 Updating Minimus firmware

The firmware of the Minimus is upgradeable. New releases appear regularly – mostly to add new features but, occasionally, to fix problems. Güralp recommends that the Minimus is regularly checked for availability of firmware updates and, when convenient, these updates should be installed.

Güralp Minimus and Minimus+

The procedure below guarantees a straightforward upgrade and prevents any data loss or misconfiguration.

Note: The latest version of Discovery software must be used to perform the firmware update of any Minimus digitiser. See section 12.5 on page **Error! Bookmark not defined.** for more details.

If you have any recorded data that you value, backup all files from the Minimus microSD card:

1. Unplug the external microSD card from your Minimus.
2. Plug the external microSD card into your PC.
3. Copy all files from the external microSD card into your PC.
4. Unplug the external microSD card from your PC.
5. Plug the external microSD card back into your Minimus.

Once this is complete, to upgrade the Minimus:

1. Run Discovery.
2. Right-click on the Minimus in Discovery main window and select "Firmware Update".
3. In the "Firmware Update" tab, select "Güralp server – stable (online version: 2.0-****)" to obtain the new firmware from the Internet via a local Ethernet connection. Click .

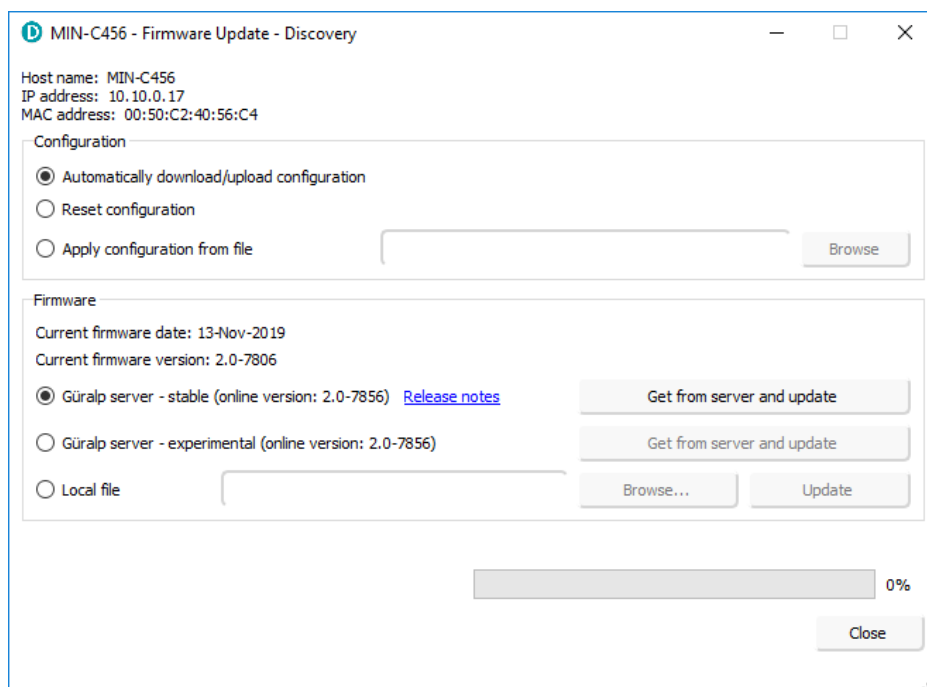

Caution: If updating from any release of v1.2 to v2.0, select the option “Güralp server - version 2.0-**** (online)” only. Do not use “Local file” option unless agreed case-by-case with support@guralp.com.

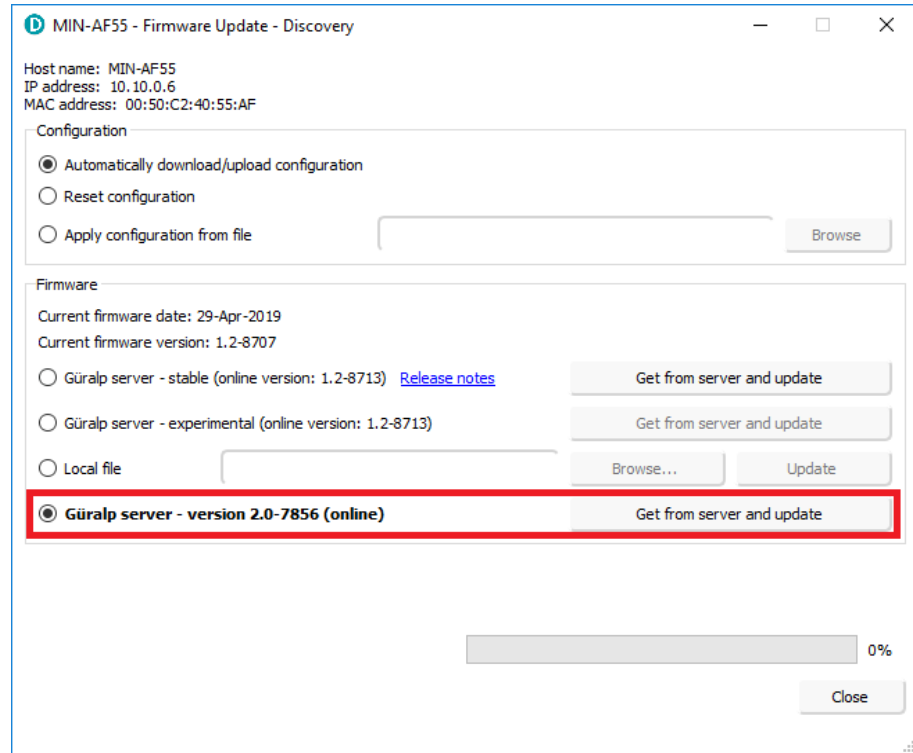

If updating from any release of below v1.2, contact support@guralp.com before proceeding.

4. Discovery will ask you if you want to save the Firmware binary file for future use – click for future use, *e.g.* update other systems offline using same firmware file. Otherwise, proceed with .

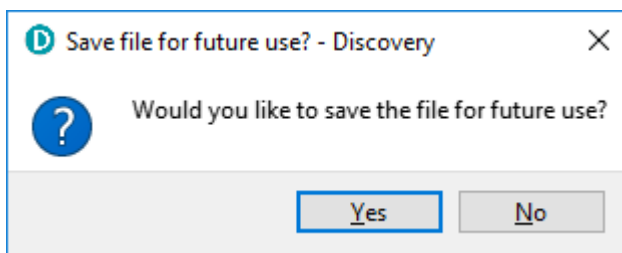

Güralp Minimus and Minimus+

5. Discovery may ask to overwrite a temporary file on your PC – click to allow it to do so.

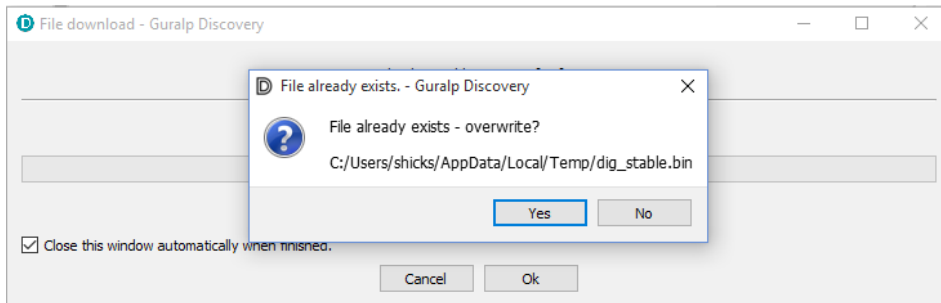

6. Discovery will confirm through another dialogue box that the file download is complete. Click to begin the firmware upload to the Minimus.

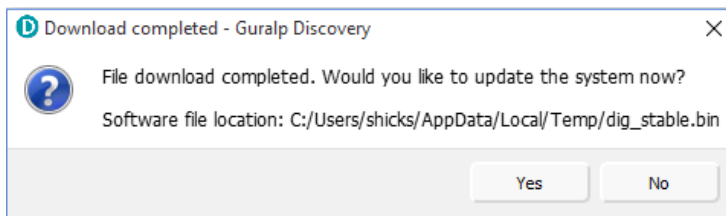

7. At the end of the uploading process, the dialogue box will ask to restart the Minimus. Click to finalise the process.

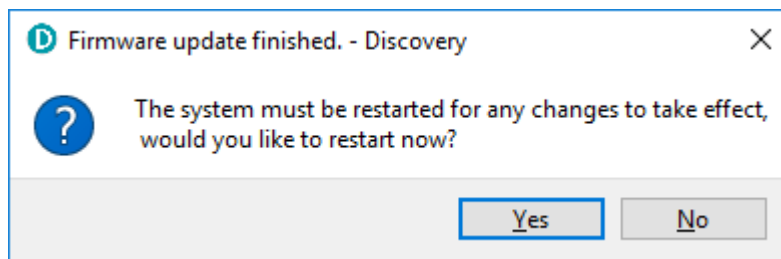

8. A dialogue box will ask you if you want to upload the previous configuration. Click to finalise the process.

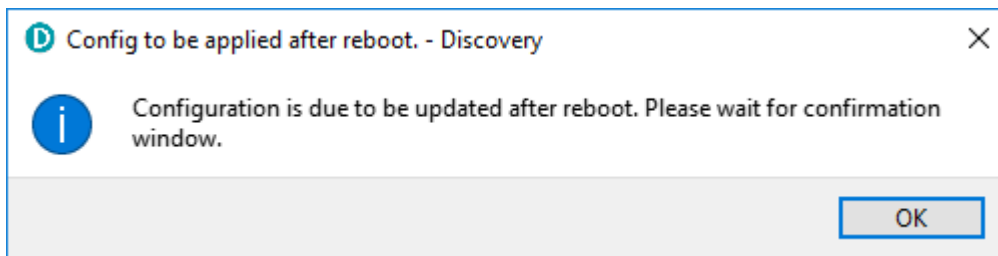

Güralp Minimus and Minimus+

- When the configuration is uploaded, the Minimus needs to be restarted again. Confirm with to the dialogue box.

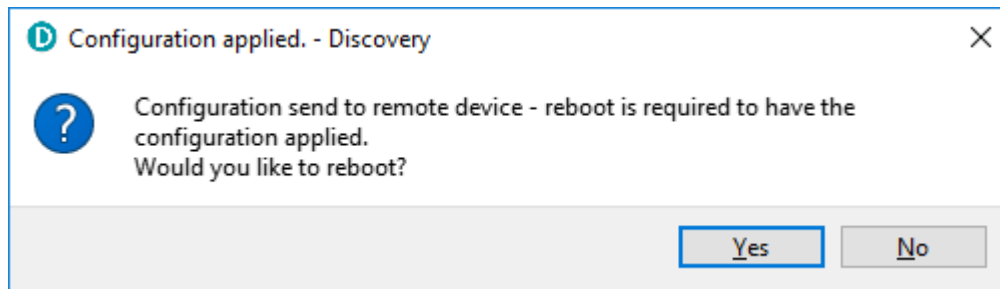

- The Minimus will re-boot and, during this process, the LED will rapidly flash white and power off for a few seconds.
- Go to the "Storage" of the Minimus web page and Quick-format the microSD cards of your Minimus (for details, see Section 5.8.2.1 on page 45).
- Check that all indicators are green (*i.e.* nothing in red nor in yellow) in Discovery.
- Go to the "Status" tab of the Minimus web page.
- Check that your Minimus firmware version is as expected.
- Check that nothing red or yellow shows up in the "Status" tab of the Minimus web page.

5.19 Import / Export an existing configuration

Updating the Minimus' firmware can, occasionally, cause loss of configuration. We recommend that you export and save the current configuration before proceeding with an upgrade. This operation can be done through Discovery by right-clicking on the digitiser in the list and selecting "System Configuration" from the context menu:

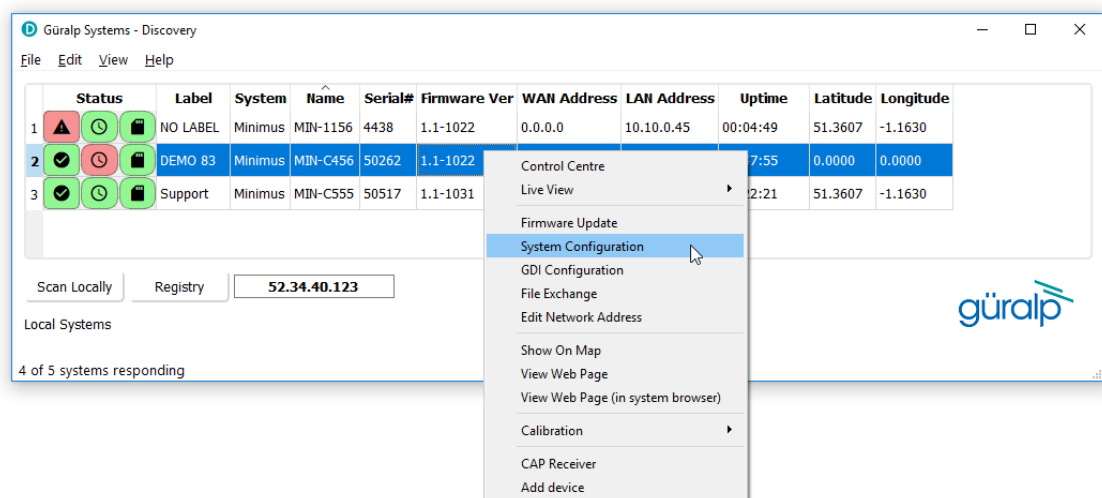

Güralp Minimus and Minimus+

Select "Use configuration from one of the devices". If more than one device is available, select the one from which the configuration should be downloaded. Click the **Download configuration** button and browse to a suitable location (on your PC) into which to save the configuration file.

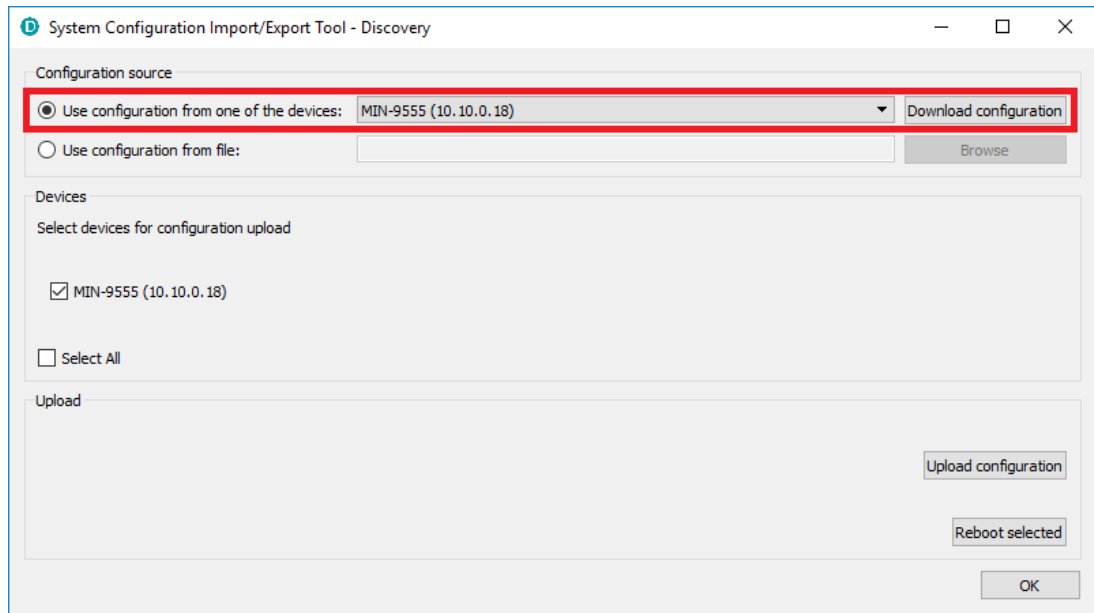

After the firmware update is successfully completed, the previous configuration can be imported, if required, by following the instructions below.

Right-click on the digitiser's entry in the Discovery list and select "System Configuration" from the context menu. Select the "Use configuration from file" option.

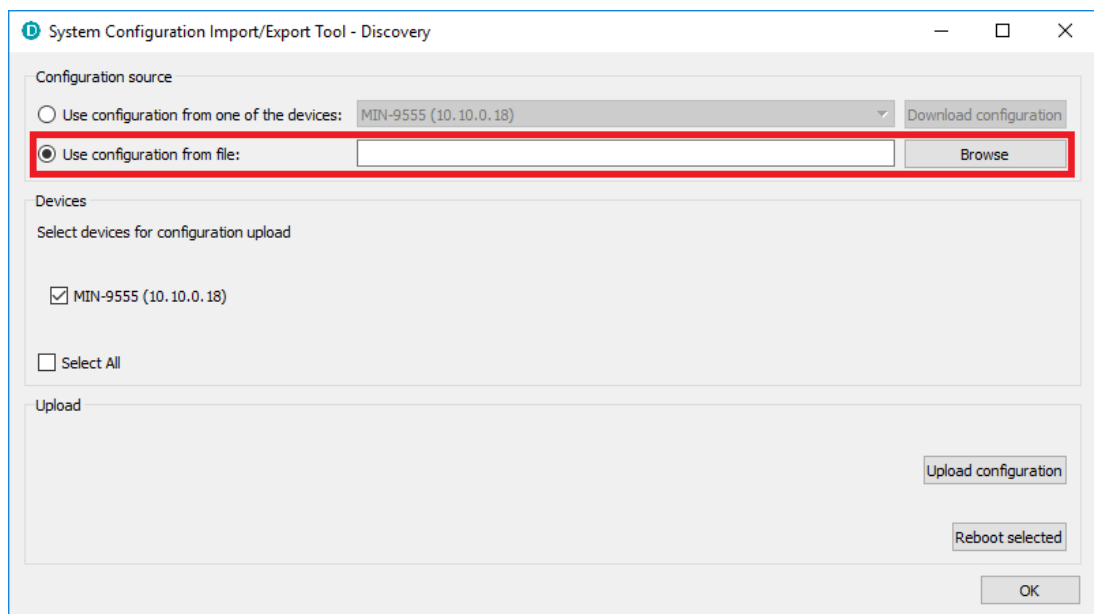

Güralp Minimus and Minimus+

Select the configuration file from where it was saved in the File Explorer and confirm. Use the check-boxes to select the devices to which the configuration should be uploaded and click on the **Upload configuration** button.







Wait until the process finishes. To apply the new configuration, the unit has to be rebooted: the **Reboot selected** button can be used to perform the required system restarts.

Note: The configuration export and upload doesn't preserve the settings related to the applied transforms.

5.20 Control Centre

Several actions can be taken from within Discovery to control any of the instruments connected to the Minimus as well as the digitiser itself.

This operation can be done by right-clicking on the digitiser's entry in the list and select "Control Centre" from the context menu. The meanings of the icons are given in the table below.

Icon	Function
 State of health	This tab provides information about the general state of the digitiser, its serial number and I.P. address, its up-time (time since last boot) and GNSS status.
 Console	This button launches a console that allows interactions with the command line of the Minimus. The list of available commands and their respective descriptions can be displayed by entering the command "help". This should generally only be done on the advice of the Güralp technical support team.
 Webpage	This button is equivalent to the "View Web Page" entry in the context (right-click) menu of the Minimus in the Discovery main window.
 Map	This button is equivalent to the "Show on Map" entry in the context (right-click) menu of the Minimus in the Discovery main window.
 Live data view	This button is equivalent to the "Live View" entry in the context (right-click) menu of the Minimus in the Discovery main window.
 Holelocks control	Hole-lock control for attached Radian instruments. Please refer to MAN-RAD-0001 for full details.
 Centring	This tab allows manual centring of connected analogue and digital (e.g. Radian) instruments. Please refer to MAN-RAD-0001 for details about centring Radian instruments.

Güralp Minimus and Minimus+

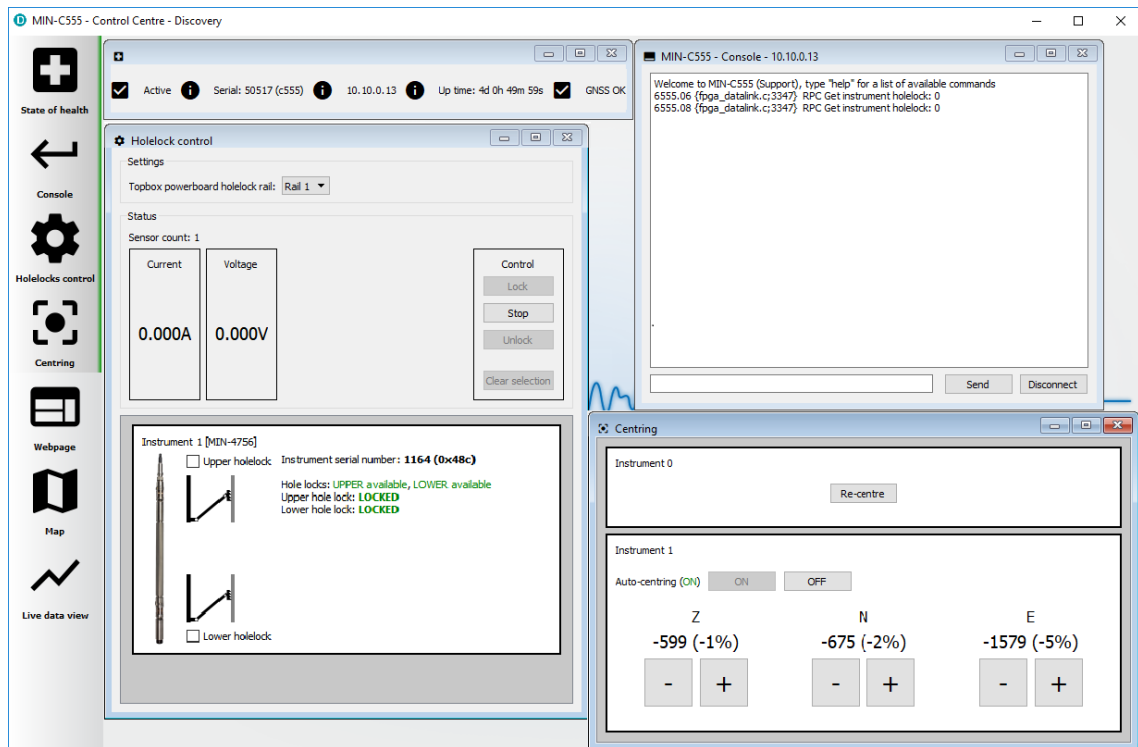

6 Scripting

The digitiser is capable of running a script file that contains commands to execute at specific dates and time.

This can be used for operations such as scheduled instrument calibrations.

The script file is written on a computer as a .txt file. It is then sent to the digitiser as a file transfer from Discovery (running on a PC, Laptop or Linux system)

6.1 Enabling

This capability needs to be enabled (once) on the digitiser as follows:

On the serial diagnostics port of the device type the command below. The serial port can be accessed from Discovery by double clicking the device in the list and selecting the console tab.

```
MINP-7163-> resource add futrcmds 1
```

Güralp Minimus and Minimus+

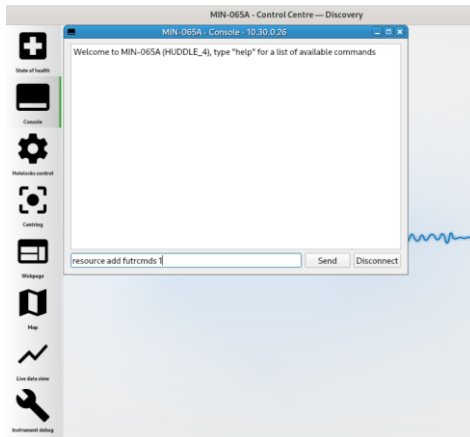

6.2 Sending a script file

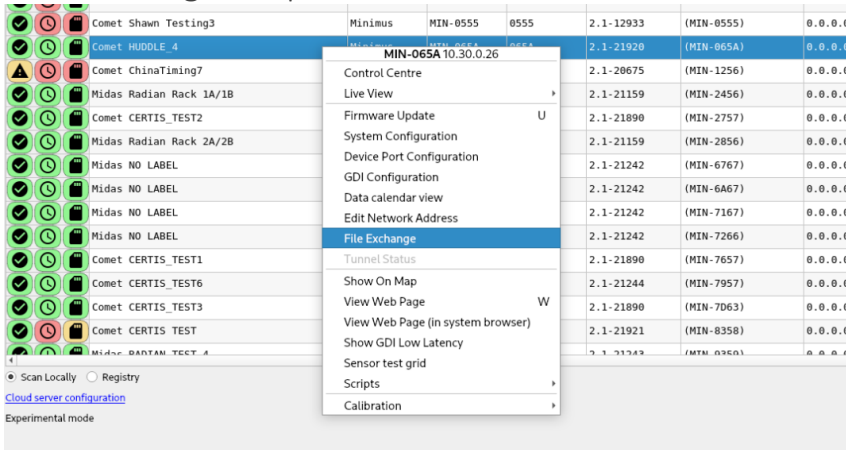

FIGURE 1 CHOOSING DIGITISER TO TRANSFER SCRIPT FILE

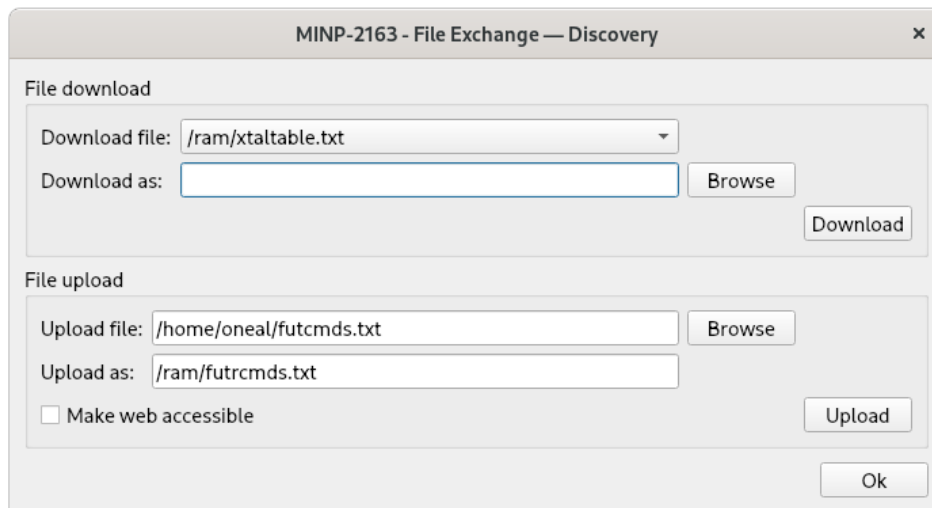
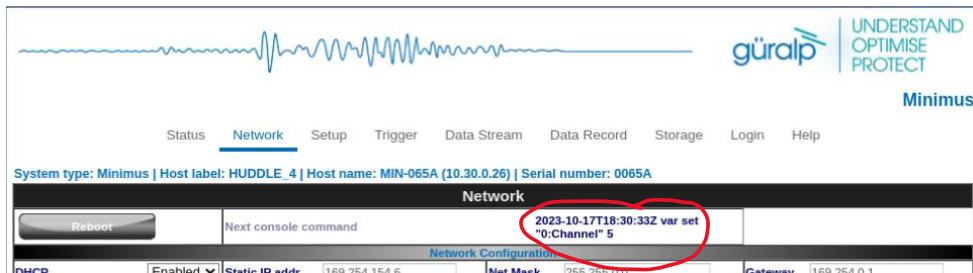

FIGURE 2 FIGURE 2 SELECTING THE SCRIPT FILE

Güralp Minimus and Minimus+

The next command due to be executed is displayed in the Network Tab as shown below:



6.3 Commands within the script file

Any commands available on the digitiser serial diagnostics port can be used. The examples below can be used to enable the calibration signal generator at specific **times**:

```
var set 0:Calibration 1
```

The number '1' represents the enumeration of the pulldown list

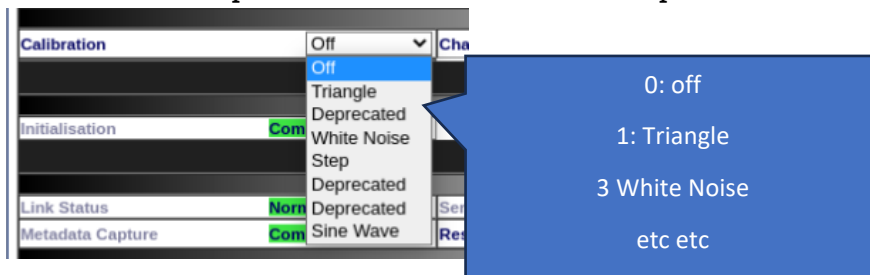

6.4 Example to instigate calibration

```
2023-10-17T18:30:33Z      var set "0:Channel" 5
```

```
2023-10-17T18:30:50Z      var set "0:Lookup generator speed" 7
```

```
2023-10-17T18:30:55Z      var set "0:Calibration" 7
```

```
2023-10-17T18:35:13Z      var set "0:Calibration" 0
```

```
2023-10-17T18:35:33Z      var set "0:Channel" 0
```

Note: The circles space is the TAB character. Using spaces instead won't work!

Güralp Minimus and Minimus+

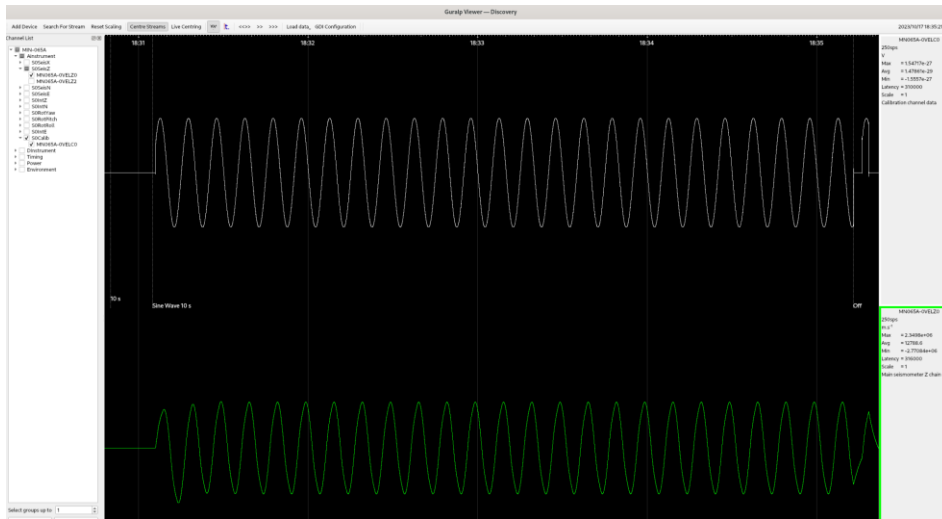

FIGURE 3 RESULTING CAL AS SEEN ON DISCOVERY

6.5 Status of the script running process

```
MINP-7163-> futrcmds show
config = 1
2023-04-11T09:59:13Z      system time
2023-04-11T09:59:33Z      ver
2023-04-11T09:59:53Z      futrcmds ?
offset = 0x0000
MINP-7163-> system time
```

Tue Apr 11 09:58:59 2023

```
MINP-7163-> futrcmds clear
```

Note: sending a new script file replaces the existing queued up commands

The clear command removes the entire script.

6.6 Example futrcmds.txt file

The following file will create a single step calibration (Positive then negative step 11 minutes apart) on 2023-04-17 at 03:30 UTC.

```
2023-04-17T03:28:00Z  var set "0:Calibration" 4
2023-04-17T03:28:20Z  var set "0:Lookup generator gain" 0
2023-04-17T03:28:40Z  var set "0:Channel" 5
2023-04-17T03:30:00Z  var set "0:Lookup generator gain" 1106247680
2023-04-17T03:41:00Z  var set "0:Lookup generator gain" 0
2023-04-17T03:47:00Z  var set "0:Channel" 0
2023-04-17T03:47:20Z  var set "0:Calibration" 0
```

Güralp Minimus and Minimus+

6.6.1 0:Calibration 4

This command will set the signal type, in this example 4 will create a step on sensor 0, other options include, sinewave, triangle wave and random noise.

Note the script waits for 10 seconds before the next command.

6.6.2 0:Lookup generator gain 0

This will set the gain of the step to 0 volts, note the script waits for 10 seconds before the next command.

6.6.3 0:Channel 5

This switches the logic lines for the 'calibration enable'. Please note the script then waits 2 minutes before the next command to avoid any disruption to the analogue signals during the calibration cycle.

6.6.4 0:Lookup generator gain 1106247680

This will set the gain to 30% of maximum. This is the time of the step.

6.6.5 0:Lookup generator gain 0

This will return the input signal to 0 volts.

On a velocity sensor this is the equivalent of a negative step.

6.6.6 0:Channel 0

This switches off the logic lines of the 'calibration enable'.

6.6.7 0:Calibration 0

This command will switch off the DAC creating the calibration signal and **stop the recording of the special calibration channel**

7 GüVü app

The GüVü app provides monitoring and control of near-by Minimus digitisers using the Bluetooth protocol. It is available for both Android and Apple devices.

GüVü can be downloaded from the Google Play store at:

<https://play.google.com/store/apps/details?id=com.guralp.whisper>

or from the Apple store at:

<https://itunes.apple.com/us/app/id1208418113>

7.1 Getting stated

To launch GüVü, follow the steps shown in the figure below:

Güralp Minimus and Minimus+



Steps for launching the GüVü App:

1. Launch by clicking on the GüVü icon from either the Apps Menu or from the Home Screen.
2. Wait a few seconds for the app splash screen.
3. Press the Bluetooth icon () to enable Bluetooth connectivity (if not already enabled) and to search for available devices to with which to pair.
4. Select the appropriate Minimus device from the list to pair. Wait a few seconds for the main viewer screen to show.

The instrument connection screen can also be accessed by pressing the menu icon () on the main instrument status window, and selecting the “Connect” option.

If you experience problems connecting, try forcing GüVü to quit and then re-launching the app.

Güralp Minimus
and Minimus+

Once the device is connected, the main view of the app will be displayed. This screen displays a number of status indicators associated with both the Minimus and connected sensors. These features are summarised in the figure below:

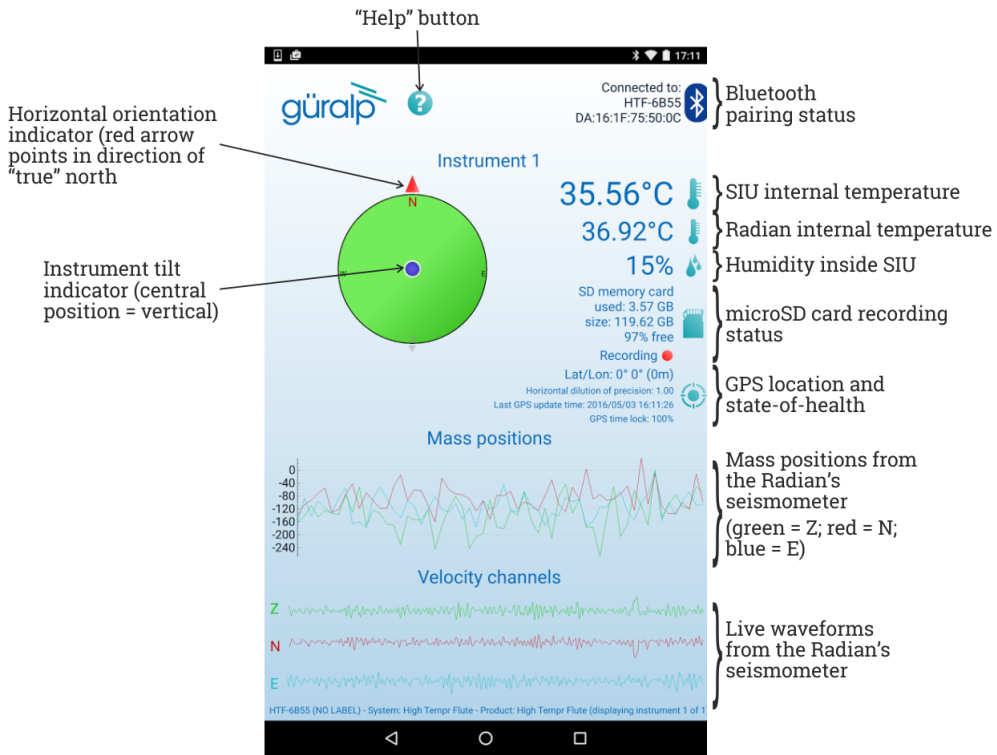

Access the menu by pressing the menu icon () on the main instrument status window:

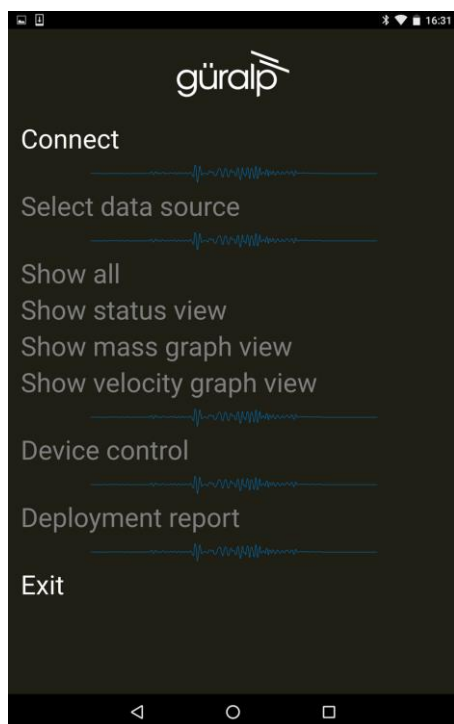

Güralp Minimus and Minimus+

7.2 Selecting data sources

Güralp view can provide status information about all connected sensors, including digital instruments (*e.g.* Güralp Radian) and analogue instruments.

To select the instrument source that provides information to the main status screen of GüVü, tap the menu icon () on the main instrument status window, and then tap the "Select data source" option.

The data source selection screen shows a list of connected instruments. Select an instrument name: this is now the instrument that will be displayed on the main instrument status window.



7.3 View settings

The user can customise the view of the main instrument status window. Four different view options can be cycled through by tapping the menu icon () on the main instrument status window:

- **Show all** – the default view setting; show state-of-health status, mass positions, and sensor traces on a single screen;
- **Show status view** – show state-of-health on the main screen only;
- **Show mass graph view** – show mass position traces on the main screen only; and
- **Show velocity graph view** - show sensor traces on the main screen only.

Güralp Minimus and Minimus+

7.4 Instrument control

Several features of the Minimus and connected instruments can be controlled and configured remotely over Bluetooth using GüVü:

- Analogue instrument centring
- Clearing and un-mounting SD card
- Rebooting the Minimus
- Enable/disable power-saving mode
- Lock/unlock sensor masses
- Station meta-data (User Label, Station Name, Network Code, Site Name)
- Network setting (I.P., Netmask, Gateway)
- Changing channels' sampling rates

In each case, GüVü will report whether the selected command has been successfully sent to the device.

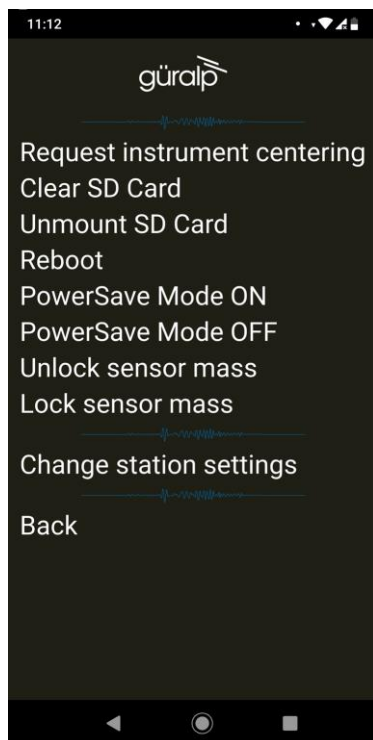

Note: After any modification to channels' sampling rates, the Minimus must be rebooted before the changes will take effect.

These options can be accessed by tapping the menu icon () and choosing the "Device control" option. To access the instrument control and configuration sub-menu, a PIN code has to be entered by selecting the text entry box and tapping .

Güralp Minimus and Minimus+

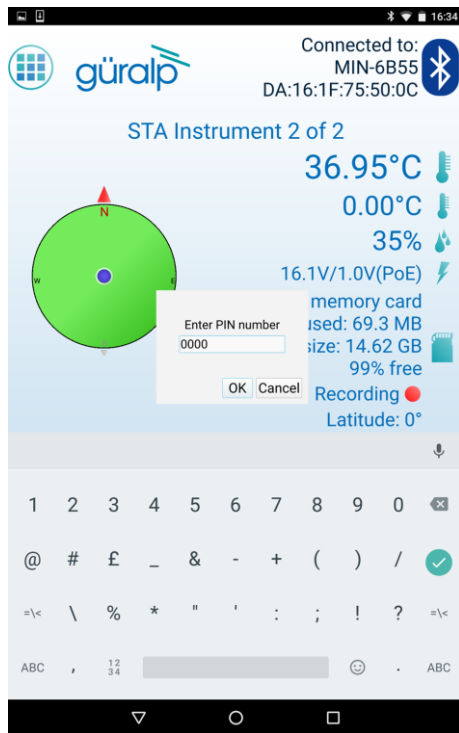

The default PIN code used to access the Instrument Control menu is "0000".

Caution: Güralp recommends changing the PIN code from the default, as described in the following section, in order to maintain station security.

7.4.1 Setting the PIN code

The PIN code for accessing the instrument control menu of GüVü can be changed from the "Setup" tab of the web page. The new four-digit PIN code should be entered into the "Bluetooth PIN" field. The new value is applied by keying ; or clicking the left mouse button in any other setting box.

Digitizer Config			
Auto Refresh	<input type="text" value="1"/>	Auto Reboot	<input type="text" value="On Error"/>
Host Label	<input type="text" value="SPRT-MIN"/>	Station Code	<input type="text" value="TEST"/>
Bluetooth PIN	<input type="text" value="0000"/>	Bluetooth	<input type="text" value="Enabled"/>
Deploy Mode	<input type="text" value="Normal"/>	Deploy	<input type="text" value=""/>

7.5 Emailing a deployment report

The GüVü app has a feature that allows the user to generate an automatic deployment report that can then be filed via email.

The deployment report includes the following details:

- System name;
- Station name;

Güralp Minimus and Minimus+

- Network code;
- Instrument user label;
- Memory card storage size and recording status;
- Location of site (GNSS latitude, longitude, elevation);
- Time of deployment;
- GNSS lock quality;
- Power supply status;
- Instrument temperature and humidity recordings.

To send a deployment report, tap the menu icon () and choose the "Deployment report" option. GüVü will then open the default email application on the device, showing a draft email which will include the parameters described above.

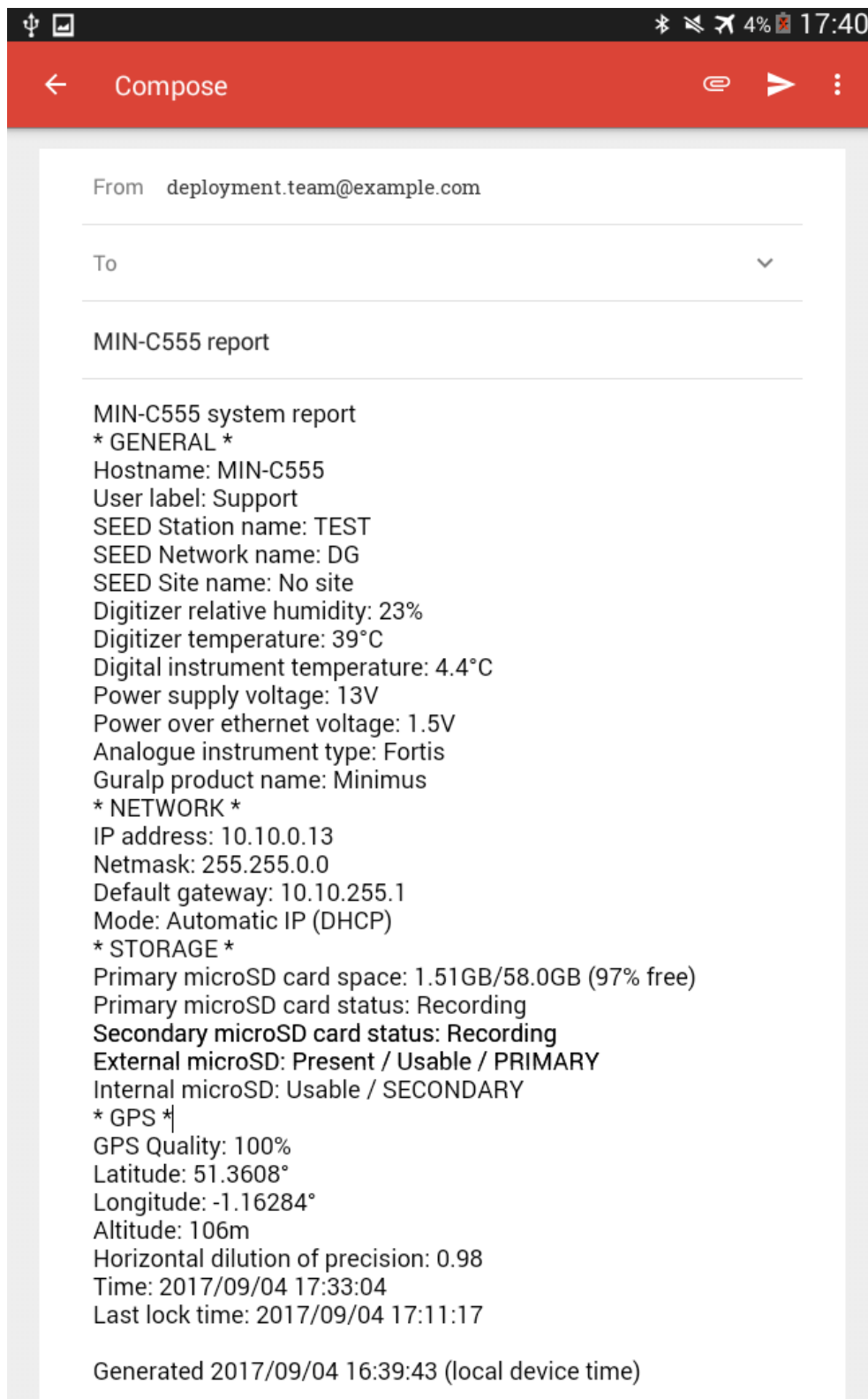

8 Advanced troubleshooting

In the unlikely event of the user experiencing problems with the operation of the Minimus, a diagnostics tool is available via the GNSS connector. This connector provides a serial console which can be accessed using a terminal emulator.

The user should first plug in the serial adapter to the GNSS connector, which is then attached to a 9-pin COM port on your PC/laptop (if a 9-pin COM port is not available, a serial-to-USB converter should be used instead and connected to an available USB port. Güralp recommend converters based on the FTDI chip-set.)

A connection is then made using a terminal emulator, such as minicom under Linux or PuTTY under Windows. The appropriate COM port should be entered as the "Serial line", and the "Speed" should be set to 115200.

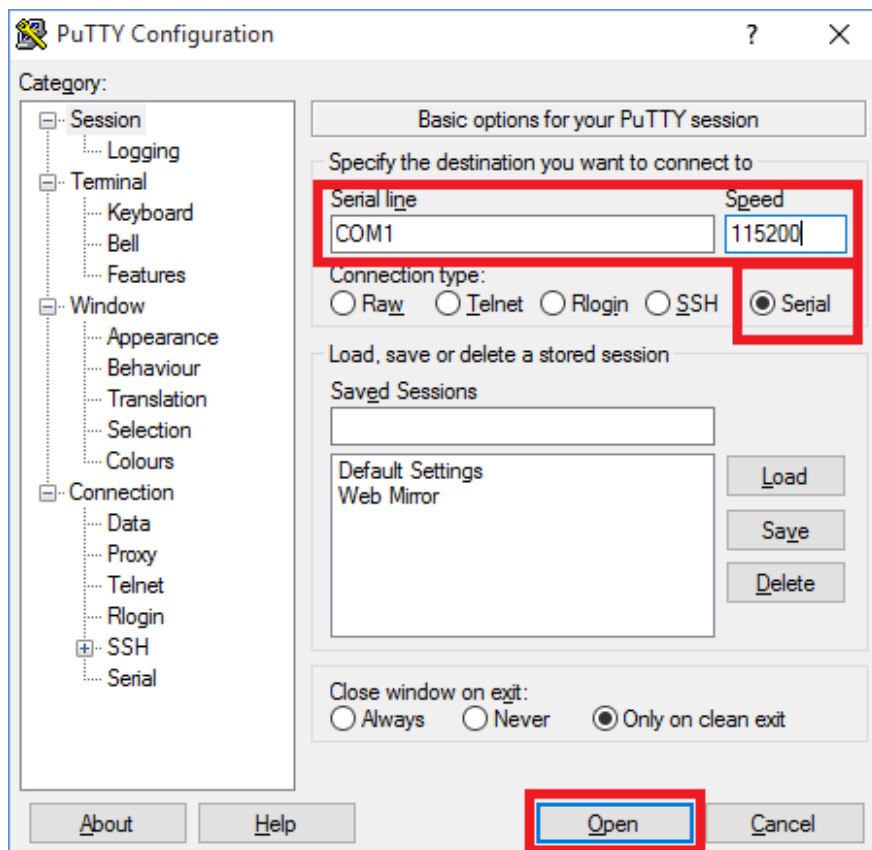

Next, select "Serial" from the bottom of the Category menu in the left-hand pane and check that the settings match those shown in the screen-shot below.

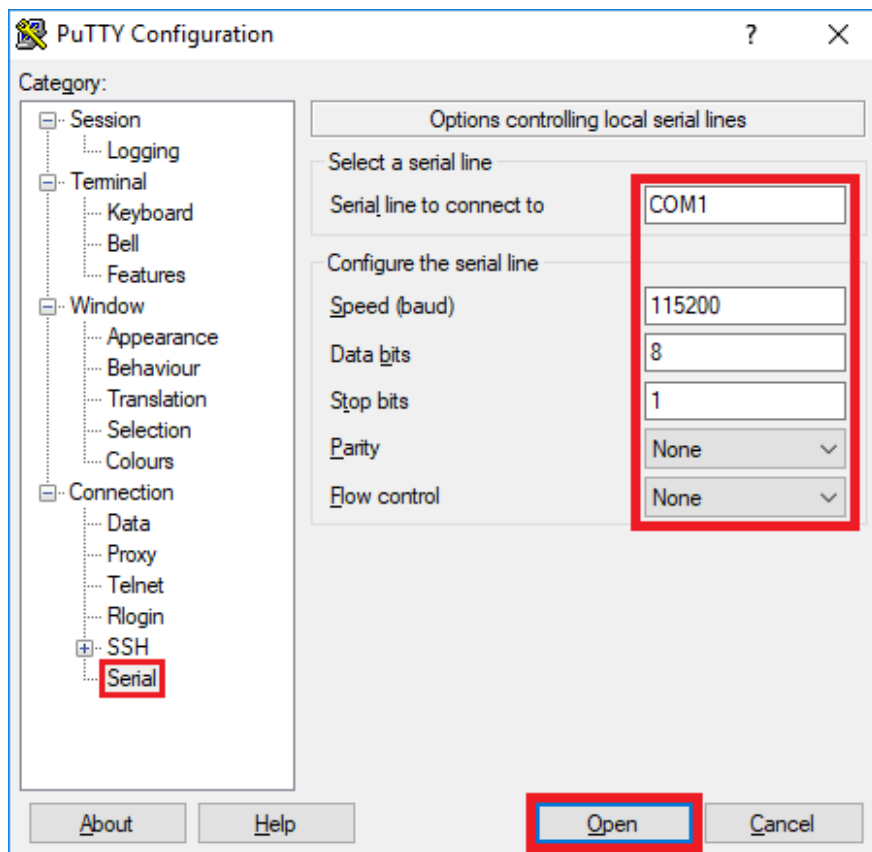

Finally click the **Open** button and a terminal window will open, connected to the console of the Minimus.

In the event of any operational issues, the Güralp Support Team may request you to interact with the console in order to diagnose and fix problems.

8.1 Reset all settings during boot phase

The Minimus can be reset to its factory settings during its boot-up stage. This is useful in cases where the user is not able to communicate with the Minimus via a network connection, where the unit is not responsive, or where it does not appear in the Discovery software's scan results.

To carry out a full system reset, connect to the terminal port via a serial connection (as described in Section 7 on page **Error! Bookmark not defined.**). During the middle part of the boot phase, when the text @GURALP SYSTEMS and the firmware version

number is displayed, key **Ctrl** + **R**. This causes all settings (except Username, Password and Bluetooth PIN) to revert to their factory default values, and the Minimus will re-boot. It may be necessary to enter this key combination several times.

A typical boot log is shown below, identifying the stages where **Ctrl** + **R** will cause the Minimus to reset and re-boot.

Güralp Minimus and Minimus+

Do not press any buttons during the first phase of boot-up:

```
Rebooting system, please wait...

00000101

0000c1c1 RomBOOT

SCKC_CR = 0xA, CKGR_MOR = 0x100FF0A, CKGR_PLLAR = 0x20FDD101, PMC_MCKR =
0x1122, PIO_PDSR = 0xF13F7C65

SCKC_CR = 0xA, CKGR_MOR = 0x100FF0A, CKGR_PLLAR = 0x21403F01, PMC_MCKR =
0x1302, PIO_PDSR = 0xF13F7C65

AT91Bootstrap v3.8.10-1.guralp

NAND: ONFI flash detected

NAND: Manufacturer ID: 0x2C Chip ID: 0xDA

NAND: Page Bytes: 2048, Spare Bytes: 64

NAND: ECC Correctability Bits: 4, ECC Sector Bytes: 512

NAND: Disable On-Die ECC

NAND: Initialize PMECC params, cap: 4, sector: 512

NAND: Image: Copy 0x92000 bytes from 0xE000 to 0x2FA0E000

NAND: Done to load image

SCKC_CR = 0xA, CKGR_MOR = 0x100FF02, CKGR_PLLAR = 0x21403F01, PMC_MCKR =
0x1302, PIO_PDSR = 0xF23F7C65

U-Boot v2019.10-1.guralp

CPU: SAMA5D36

External clock: 12.288 MHz

CPU clock: 497.664 MHz

Master clock: 165.888 MHz

DRAM: 256 MiB

NAND: 256 MiB

MMC: Atmel mci: 0, Atmel mci: 1

Loading Environment from NAND... OK

In: serial

Out: serial
```

Güralp Minimus and Minimus+

```
Err:  serial

Net:  eth0: ethernet@f0028000

word at 0xffffea20 (0x06) != word at 0x23000008 (0x07)

Total of 0 word(s) were the same

PHY 0x07: OUI = 0x0885, Model = 0x22, Rev = 0x02, 10baseT, HDX

Hit any key to stop autoboot:  0

NAND read: device 0 offset 0x5C0000, size 0x360000

 3538944 bytes read: OK

Uncompressed size: 5008508 = 0x4C6C7C

crc32 for 21000000 ... 214c6c7b ==> 6f7d4b5e

Total of 2 word(s) were the same

word at 0xffffea20 (0x06) != word at 0x23000008 (0x07)

Total of 0 word(s) were the same

## Starting application at 0x00300000 ...

(boot)Crash Info###

Number of crash left=0



(boot)Last crash time:1970-01-01T00:00:00.000

Board type set to: Minimus

Recognised external clock: 12288000 Hz

SCKC_CR = 0xA, CKGR_MOR = 0x100FF02, CKGR_PLLAR = 0x21403F01, PMC_MCKR =
0x1302, MCK = 165888000 Hz

@GURALP SYSTEMS
```

Once the “@GURALP SYSTEMS” banner has been printed, keying  +  (at least once) will cause all settings (except Username, Password and Bluetooth PIN) to revert to their default values and cause the Minimus to reboot.

```
v2.0-7548 by teamcity on 14:28:48 07-Nov-2019

Vecbase: 300000 CPUid: 410fc051 Cache: c5187d

PMT init

Unsafe to change DBGU clock while running

mux start SP 300fb4

FPU start
```

Güralp Minimus and Minimus+

```
VFP Id=41023051

0.00 | -> init_dbgprint
0.00 | -> init_cmdutils
0.00 | -> init_pmt_dlg
0.00 | -> init_memdlg
0.00 | -> malloc_debug
0.00 | -> start_timer_interrupts
0.01 | -> rtc_init

RTC Time: 2019-11-08T14:23:11 UTC

0.01 | -> uart_start_ints
0.01 | -> init_arm_parse
0.01 | -> t_init_task_utils
0.01 | -> gpio_init

##### NORMAL INITIALISATION MODE #####

0.01 | -> unit_test_init
0.01 | -> init_devio
0.01 | -> init_usart
0.01 | -> init_devio_cmds
0.01 | -> rpc_init
0.01 | -> ram_init
0.01 | -> ram_exchange_init
0.01 | -> system_update_init
```

If your key-strokes have been recognised, Ctrl+R will be printed in the boot log, as shown below – once for each time your keystrokes were logged:

```
C0.01 | -> i2c_init
i2c_configure( 0, 100000Hz )
Using pclk 41472000, cdiv 203, shift 0 => 100173
i2c_configure( 1, 100000Hz )
Using pclk 41472000, cdiv 203, shift 0 => 100173
i2c_configure( 2, 100000Hz )
Using pclk 41472000, cdiv 203, shift 0 => 100173
0.01 | -> i2c_dac_init
```

Ctrl+R

Ctrl+R

Güralp Minimus and Minimus+

Ctrl+R

Ctrl+R

Ctrl+R

Ctrl+R

Ctrl+R

```
0.01 | -> i2c_dac_init
0.01 | -> i2c_humid_init
Humidity sensor test SUCCESS
0.01 | -> fram_init
Installing NVR device. size 12640
0.04 | -> net_sockets_init
0.06 | -> newtask_init
USE ADC MINIMUS
0.07 | -> init_whalesong
0.07 | -> analog232_init
0.07 | -> start_timers
Warning non-integer microsecond divisor from 82944000
0.08 | -> spi_datalink_init_semaphores
0.09 | -> chain_init
Using 251 coefficients.
0.15 | -> var_user_init
[SD log not available!] User variable "last_loc_lat" modified (called
from load_from_fram)
[SD log not available!] User variable "last_loc_lon" modified (called
from load_from_fram)
[SD log not available!] User variable "station_start_t" modified (called
from load_from_fram)
[SD log not available!] User variable "DHCP" modified (called from
load_from_fram)
[SD log not available!] User variable "Static IP addr" modified (called
from load_from_fram)
[SD log not available!] User variable "Net Mask" modified (called from
load_from_fram)
[SD log not available!] User variable "Gateway" modified (called from
load_from_fram)
[SD log not available!] User variable "DNS1" modified (called from
load_from_fram)
```

Güralp Minimus and Minimus+

```
[SD log not available!] User variable "DNS2" modified (called from
load_from_fram)

[SD log not available!] User variable "Username" modified (called from
load_from_fram)

[SD log not available!] User variable "Password" modified (called from
load_from_fram)

[SD log not available!] User variable "tunnel_password" modified (called
from load_from_fram)

[SD log not available!] User variable "tunnel_username" modified (called
from load_from_fram)

[SD log not available!] User variable "tunnel_connection" modified
(called from load_from_fram)

[SD log not available!] User variable "Host Label" modified (called from
load_from_fram)

[SD log not available!] User variable "Station Code" modified (called
from load_from_fram)

[SD log not available!] User variable "Network Code" modified (called
from load_from_fram)

[SD log not available!] User variable "Site Name" modified (called from
load_from_fram)

[SD log not available!] User variable "Bluetooth PIN" modified (called
from load_from_fram)

[SD log not available!] User variable "Filter quality" modified (called
from load_from_fram)

[SD log not available!] User variable "CAP Msg HMAC Key" modified (called
from load_from_fram)

[SD log not available!] User variable "Registry Address" modified (called
from load_from_fram)

[SD log not available!] User variable "tunnel_url" modified (called from
load_from_fram)

[SD log not available!] User variable "Password (Normal)" modified
(called from load_from_fram)

[SD log not available!] User variable "Username (Admin)" modified (called
from load_from_fram)

[SD log not available!] User variable "Password (Admin)" modified (called
from load_from_fram)

[SD log not available!] User variable "Username (Normal)" modified
(called from load_from_fram)

[SD log not available!] User variable "Group ID" modified (called from
load_from_fram)

0.45 | -> calibration_init

1.91 | -> gcftx_init
```

Güralp Minimus and Minimus+

```
1.92 | -> spi_datalink_chains_init
Sensor0 is velocimeter
Sensor1 is accelerometer
Sensor2 is velocimeter
Sensor3 is velocimeter
Sensor4 is velocimeter
Sensor5 is velocimeter
Sensor6 is velocimeter
Sensor7 is velocimeter
Sensor8 is velocimeter

3.33 | -> init_nand
4.17 | -> adc12_init
4.18 | -> init_random
4.18 | -> ltc4151_vc_monitor_init
Voltage/Current readings are not provided by LTC4151 chip.
4.19 | -> voltage_sniffer_init
4.20 | -> init_lut
4.28 | -> i2c_humid_init_ui
4.30 | -> sd_init
4.31 | -> sd_file_init
4.31 | -> sd_log_init
4.31 | -> streaming_client_init
2019-11-08T14:23:15.000Z Retime Request Waiting (35s/3600s/Boot delay)
4.33 | -> xtaltable_init
No XTAL table found.
4.40 | -> gps_pps_init
Chain 54 already set.
Chain 54 already set.
Chain 54 already set.
Chain 54 already set.
Chain 54 already set.
Chain 54 already set.
Chain 54 already set.
Chain 54 already set.
Chain 54 already set.
```

Güralp Minimus and Minimus+

```
MIN-C555->      4.44 | -> init_var_debug
                4.44 | -> tcpdump_init
                4.45 | -> var_html_init
                4.45 | -> init_http_server
                4.46 | -> sd_init_var
                4.46 | -> gps_pps_ui_init
                4.46 | -> xtaltable_ui_init
checking for xtaltable.txt
                4.47 | -> init_fpga_datalink
                4.47 | -> init_auto_center
                4.48 | -> init_embedded_fs
                4.48 | -> status_txt_init
                4.49 | -> lan_init_web

#####tx_lock:
majic:f710f7f7
Call_lock value:-1      4.50 | -> init_responder_ui
                4.51 | -> init_tunnel_ui
                4.52 | -> quasar_init
Quasar Serial Isolated Input/Output Module support is disabled.
                4.53 | -> quasar_init_ui
                4.53 | -> applied_rot_init_web
                4.54 | -> installation_parameters_init_web
                4.55 | -> init_fpga_web
                4.62 | -> analog232_init_web
                4.73 | -> init_transforms
                4.74 | -> triggers_init_ui
                5.02 | -> chain_init_web
                10.52 | -> transform_init_web
                13.14 | -> storage_init_web
                13.19 | -> spi_datalink_ui_init
                13.32 | -> gps_init_ui
                13.33 | -> gps_init
```

Güralp Minimus and Minimus+

Once the boot-up reaches this stage, pressing **Ctrl** + **R** will have no effect.

If **Ctrl** + **R** was recognised during the second stage of boot-up, then the Minimus will reset and re-boot:

Ctrl+R NVR load, resetting all vars to their default values and then re-booting

```
Forcing all vars to default values (including non-default-able)
PPS clock sources ACTIVE: 0x00000001 [GPS:0 PTP:0 RTC:0 TABLE:1]
PPS clock sources ACTIVE: 0x01000001 [GPS:1 PTP:0 RTC:0 TABLE:1]
PPS clock sources ACTIVE: 0x01010001 [GPS:1 PTP:1 RTC:0 TABLE:1]
PPS clock sources ACTIVE: 0x01010101 [GPS:1 PTP:1 RTC:1 TABLE:1]

Ctrl+R
Ctrl+R
Ctrl+R

sd_manager: probed both microSD card slots

11.58 {calibration.c;1142} calibration_write_to_fram: successfully wrote
calib to FRAM

11.60 {var_nvr.c;773} 'sd_format_time' $20301021 --> $00000000
11.61 {var_nvr.c;773} 'sd_unmount_time' $22647008 --> $00000000
11.62 {var_nvr.c;773} 'pps_src_table' 168 --> 1
11.63 {var_nvr.c;773} 'pps_src_gps' 0 --> 1
11.63 {var_nvr.c;773} 'pps_src_ptp' 69 --> 1
11.64 {var_nvr.c;773} 'pps_src_rtc' 132 --> 1
11.64 {var_nvr.c;773} 'rtcSavedOffsetSecs_nv' -1737983855 --> 0
11.65 {var_nvr.c;773} 'rtcSavedOffsetNano_nv' 402788896 --> 0
11.66 {var_nvr.c;773} 'rtcSavedFreqErrorPPB_nv' -2129883872 --> 1000000
11.67 {var_nvr.c;773} 'rtcSavedOffsetTime_nv' $52080158 --> $00000000
11.68 {var_nvr.c;773} 'xtaltable_offset' 610275339 --> 0

:
```

9 Appendix 1 – Instrument/channel names

The tables in this section show the names and codes of the streamed channels along with the record names and channel codes for recorded data. The first character “x” in miniSEED channel code represents the sample rate. The possible values are shown in the table below:

Güralp Minimus
and Minimus+

F	≥ 1000 Hz to < 5000 Hz
C	≥ 250 Hz to < 1000 Hz
H	≥ 80 Hz to < 250 Hz
B	≥ 10 Hz to < 80 Hz
M	> 1 to < 10
L	≈ 1
V	≈ 0.1 Hz
U	≈ 0.01 Hz
R	≥ 0.0001 Hz to < 0.001

The “Data record names” of the seismic channels and MEMS accelerometer channels are postfixed with “A” or “B”. This notation distinguishes between the two different sample rates that is possible to select for each recorded channel. For example, the recorded streams *S0AccZA* and *S0AccZB* carry digitisations of the same signal, differing only in the sample rate.

Note: Throughout this section, the letter *n* in italic script is used to indicate the Instrument number, which is a small integer used to identify the signal source. This is always zero (‘0’) for the Minimus’ own internal sensors and for the first analogue instrument.

For Minimus units, Instruments 1, 2, ... 8 are external Radian instruments in a string sharing a digital connection. Instrument 1 is the digital instrument closest to the Minimus.

⚠ For Minimus+ units, Instrument 1 is the second analogue sensor. Instruments 2, 3, ... 9 are external Radian instruments in a string sharing a digital connection. Instrument 2 is the digital instrument closest to the Minimus+.

9.1 Minimus' internal sensors

Sensor	Comp.	Digital filter mode	Data streaming		Data recording	
			Live stream name	Live Stream code	Data record name	Mini SEED channel code
MEMS accelerometer	1	Acausal	S0AccZ	0AXL10	S0AccZA	xN1
					S0AccZB	xN1
	Causal	S0AccZLowLat	0AXLIC		xN1	
	2	Acausal	S0AccN	0AXL20	S0AccNA	xN2
				S0AccNB	xN2	

Güralp Minimus
and Minimus+

Sensor	Comp.	Data streaming			Data recording	
		Digital filter mode	Live stream name	Live Stream code	Data record name	Mini SEED channel code
	3	Causal	S0AccelNLowLat	0AXL2C		xN2
		Acausal	S0AccE	0AXL30	S0AccEA	xN3
					S0AccEB	xN3
Causal	S0AccelELowLat	0AXL3C		xN3		
Magnetometer	1	Acausal	S0MagZ	0MAG10	S0MagZ	xF1
	2	Acausal	S0MagN	0MAG20	S0MagN	xF2
	3	Acausal	S0MagE	0MAG30	S0MagE	xF3
Input voltage		Acausal	S0Voltage	0VINP0	S0Voltage	xYV
Power						
Humidity within the Minimus		Acausal	S0HumidA	0HUMA0	S0HumidA	xIO
Temperature	Precision temperature	Acausal	S0TemprA	0TMPA0	S0TemprA	xKO
	First derivative of temperature	Acausal	S0TemprD	0TMPD0		xKD
Internal Clock	Internal clock offset from GNSS	Acausal	ClkGpsOffset	0CGPS0	ClkGpsOffset	BEO
	Internal clock period difference from GNSS	Acausal	ClkGpsPeriod	0CGPSP	ClkGpsPeriod	BEF
	Internal clock DAC frequency pulling	Acausal	ClkDacFreqPull	0CVDAC	ClkDacFreqPull	BED
	Test internal clock drift	Acausal	ClkTestPpbS	0CTSTB	ClkTestPpbS	BEB
	Internal clock offset from PTP	Acausal	ClkPtpOffset	0CPTPO	ClkPtpOffset	BEP
	Delay MS	Acausal	ClkPtpDelayMS	0CPDMS	ClkPtpDelayMS	BEA
	Delay SM	Acausal	ClkPtpDelaySM	0CPDSM	ClkPtpDelaySM	BEB
	Mean path delay	Acausal	ClkPtpMeanPathDelay	0CPMPD	ClkPtpMeanPathDelay	BEC

Güralp Minimus
and Minimus+

9.2 Analogue Instruments

The italicised *n* in the codes is always set to zero ('0') for the first analogue instrument. \triangle For Minimus+ units, it is set to 1 for the second analogue sensor. There is an Auxiliary input on each of the analogue sensor inputs on a Minimus+ and the streams from these are similarly identified by a 0 or 1.

Sensor	Comp.	Digital filter mode	Data streaming		Data recording		
			Live stream name	Live Stream code	Data record name	Mini SEED channel code	
Analogue seismic sensor (velocimeter or accelerometer)	Vertical	Acausal	<i>S<i>n</i>SeisZ</i>	<i>n</i> VELZ0 or <i>n</i> ACCZ0	<i>S<i>n</i>SeisZA</i>	xHZ or xNZ	
			<i>S<i>n</i>SeisZ</i>	<i>n</i> VELZ2 or <i>n</i> ACCZ2	<i>S<i>n</i>SeisZB</i>	xHZ or xNZ	
		Causal	<i>S<i>n</i>SeisZLowLat</i>	<i>n</i> VELZC or <i>n</i> ACCZC	<i>Se<i>n</i>SeisZLowLat</i>	xHZ or xNZ	
		North	Acausal	<i>S<i>n</i>SeisN</i>	<i>n</i> VELN0 or <i>n</i> ACCN0	<i>S<i>n</i>SeisNA</i>	xHN or xNN
				<i>S<i>n</i>SeisN</i>	<i>n</i> VELN2 or <i>n</i> ACCN2	<i>S<i>n</i>SeisNB</i>	xHN or xNN
			Causal	<i>S<i>n</i>SeisNLowLat</i>	<i>n</i> VELNC or <i>n</i> ACCNC	<i>S<i>n</i>SeisNLowLat</i>	xHN or xNN
	East	Acausal	<i>S<i>n</i>SeisE</i>	<i>n</i> VELE0 or <i>n</i> ACCE0	<i>S<i>n</i>SeisEA</i>	xHE or xNE	
			<i>S<i>n</i>SeisE</i>	<i>n</i> VELE2 or <i>n</i> ACCE2	<i>S<i>n</i>SeisEB</i>	xHE or xNE	
		Causal	<i>S<i>n</i>SeisELowLat</i>	<i>n</i> VELEC or <i>n</i> ACCEC	<i>S<i>n</i>SeisELowLat</i>	xHE or xNE	
	Auxiliary input		Acausal	<i>S<i>n</i>SeisX</i>	<i>n</i> AUXX0	<i>S<i>n</i>SeisX</i>	xDF
	Analogue seismic sensor mass positions	Vertical	Acausal	<i>S<i>n</i>IntZ</i>	<i>n</i> VELM8	<i>S<i>n</i>IntZ</i>	xMZ
		North	Acausal	<i>S<i>n</i>IntN</i>	<i>n</i> VELM9	<i>S<i>n</i>IntN</i>	xMN
East		Acausal	<i>S<i>n</i>IntE</i>	<i>n</i> VELMA	<i>S<i>n</i>IntE</i>	xME	
Calibration Channel		Acausal	<i>S<i>n</i>Calib</i>	<i>n</i> VELC (or <i>n</i> ACCC)	<i>S<i>n</i>Calib</i>	xCA	

Güralp Minimus
and Minimus+

Sensor	Comp.	Data streaming			Data recording	
		Digital filter mode	Live stream name	Live Stream code	Data record name	Mini SEED channel code
Humidity within sensor enclosure		Acausal	<i>Sn</i> HumidB	<i>n</i> HUMB0	<i>Sn</i> HumidB	xIO
Pressure	Within sensor enclosure	Acausal	<i>Sn</i> Pressure	<i>n</i> PRSR0	<i>Sn</i> Pressure	xDI
	External	Acausal	<i>Sn</i> ExtPressure	<i>n</i> PRSR1	<i>Sn</i> ExtPressure	xDO
PLL clock offset		Acausal	<i>Sn</i> PLLOffset	<i>n</i> PLLO0	<i>Sn</i> PLLOffset	xYO

9.3 Digital Instruments

Digital instruments can be attached to the Minimus in a chain. The lowest number instrument is the one which is closest to the Minimus. On a Minimus, this is Instrument 1.  For Minimus+ units, it is Instrument 2.

Sensor	Comp	Digital filter mode	Data streaming		Data recording	
			Live stream name	Live stream code	Data record name	MiniSEED channel code
Seismometer (velocity or acceleration response)	Vertical	Acausal	<i>Sn</i> SeisZ	<i>n</i> VELZ0 or <i>n</i> ACCZ0	<i>Sn</i> SeisZA	xHZ or xNZ
			<i>Sn</i> SeisZ	<i>n</i> VELZ2 or <i>n</i> ACCZ2	<i>Sn</i> SeisZB	xHZ or xNZ
		Causal	<i>Sn</i> SeisZLowLat	<i>n</i> VELZC or <i>n</i> ACCZC	<i>Sn</i> SeisZLowLat	xHZ or xNZ
	North	Acausal	<i>Sn</i> SeisN	<i>n</i> VELN0 or <i>n</i> ACCN0	<i>Sn</i> SeisNA	xHN or xNN
			<i>Sn</i> SeisN	<i>n</i> VELN2 or <i>n</i> ACCN2	<i>Sn</i> SeisNB	xHN or xNN
		Causal	<i>Sn</i> SeisNLowLat	<i>n</i> VELNC or <i>n</i> ACCNC	<i>Sn</i> SeisNLowLat	xHN or xNN

Güralp Minimus
and Minimus+

Sensor	Comp	Data streaming			Data recording	
		Digital filter mode	Live stream name	Live stream code	Data record name	MiniSEED channel code
	East	Acausal	<i>SnSeisE</i>	<i>nVELE0</i> or <i>nACCE0</i>	<i>SnSeisEA</i>	xHE or xNE
			<i>SnSeisE</i>	<i>nVELE2</i> or <i>nACCE2</i>	<i>SnSeisEB</i>	xHE or xNE
		Causal	<i>SnSeisELowLat</i>	<i>nVELEC</i> or <i>nACCEC</i>	<i>SnSeisELowLat</i>	xHE or xNE
Digital seismic sensor mass position	Vertical	Acausal	<i>SnIntZ</i>	<i>nINTZ0</i>	<i>SnIntZ</i>	xMZ
	North	Acausal	<i>SnIntN</i>	<i>nINTN0</i>	<i>SnIntN</i>	xMN
	East	Acausal	<i>SnIntE</i>	<i>nINTE0</i>	<i>SnIntE</i>	xME
MEMS accelerometer	Vertical	Acausal	<i>SnAccZ</i>	<i>nAXLZ0</i>	<i>SnAccZA</i>	xNZ
					<i>SnAccZB</i>	xNZ
		Causal	<i>SnAccZLowLat</i>	<i>nAXLZC</i>		xNZ
	North	Acausal	<i>SnAccN</i>	<i>nAXLN0</i>	<i>SnAccNA</i>	xNN
					<i>SnAccNB</i>	xNN
		Causal	<i>SnAccNLowLat</i>	<i>nAXLNC</i>		xNN
	East	Acausal	<i>SnAccE</i>	<i>nAXLE0</i>	<i>SnAccEA</i>	xNE
					<i>SnAccEB</i>	xNE
		Causal	<i>SnAccELowLat</i>	<i>nAXLEC</i>		xNE
Magnetometer	Z	Acausal	<i>SnMagZ</i>	<i>nMAGZ0</i>	<i>SnMagZ</i>	xFZ
	N	Acausal	<i>SnMagN</i>	<i>nMAGN0</i>	<i>SnMagN</i>	xFN
	E	Acausal	<i>SnMagE</i>	<i>nMAGE0</i>	<i>SnMagE</i>	xFE
	Yaw	Acausal	<i>SnRotYaw</i>	<i>nROTY0</i>	<i>SnRotYaw</i>	xYY
	Pitch	Acausal	<i>SnRotPitch</i>	<i>nROTP0</i>	<i>SnRotPitch</i>	xYP
	Roll	Acausal	<i>SnRotRoll</i>	<i>nROTR0</i>	<i>SnRotRoll</i>	XYR
Temperature		Acausal	<i>SnTemprB</i>	<i>nTMPB0</i>	Sensor <i>nTemprBRough</i>	xKO
Humidity within sensor enclosure		Acausal	<i>SnHumidB</i>	<i>nHUMB0</i>	<i>SnHumidB</i>	xIO
Pressure	Within sensor enclosure	Acausal	<i>SnPressure</i>	<i>nPRSR0</i>	<i>SnPressure</i>	xDI

Güralp Minimus and Minimus+

Sensor	Comp	Data streaming			Data recording	
		Digital filter mode	Live stream name	Live stream code	Data record name	MiniSEED channel code
	External	Acausal	<i>Sn</i> ExtPressure	<i>n</i> PRSR1	<i>Sn</i> ExtPressure	xDO
PLL clock offset		Acausal	<i>Sn</i> PLLOffset	<i>n</i> PLLO0	<i>Sn</i> PLLOffset	xYO
Sensor power		Acausal	<i>Sn</i> Power	<i>n</i> PWR0	<i>Sn</i> Power	xEO
Sensor input voltage		Acausal	<i>Sn</i> Voltage	<i>n</i> VOLT0	<i>Sn</i> Voltage	xE1

10 Appendix 2 – Minimus network ports

The following network ports are used by the Minimus:

Port	Layer 4 Protocol	Description
80	TCP	HTTP server
1565	TCP	GDI transmission protocol
1567	TCP/UDP	GCF transmission protocol
4242	TCP	File exchange protocol
4244	TCP	Remote console
11788	UDP	Remote procedure calls
18000	TCP	SEEDlink transmission protocol

11 Appendix 3 – Connector pin-outs

11.1 Ethernet

This is an Amphenol RJField-series 8P8C connector. It consists of a standard ISO 8877 8P8C modular socket (often called RJ45) in a bayonet mounting compatible with MIL-DTL-26482 (formerly MIL-C-26482).

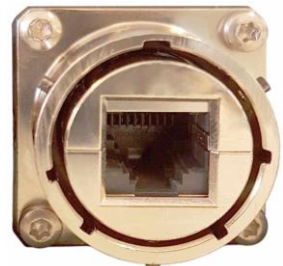

Pin	10BASE-T & 100BASE-TX	1000BASE-T
1	Transmit Data +	BI_DA+
2	Transmit Data -	BI_DA-
3	Receive Data +	BI_DB+

Güralp Minimus
and Minimus+

4	<i>not connected</i>	BI_DC+
5	<i>not connected</i>	BI_DC-
6	Receive Data -	BI_DB-
7	<i>not connected</i>	BI_DD+
8	<i>not connected</i>	BI_DD-



This connector accepts unmodified ISO 8877 8P8C modular connectors (often called RJ45 connectors or Ethernet "Cat 5/6" connectors).

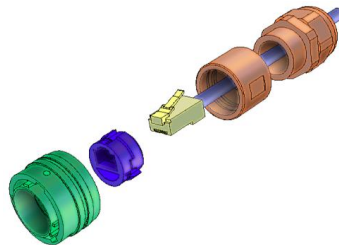

When used in hostile environments, a standard Ethernet cable can have a mating environmental shield (Amphenol part number RJF6MN) fitted.

11.2 Power

This is a standard 4-pin military-specification bayonet plug, conforming to MIL-DTL-26482 (formerly MIL-C-26482).



Pin	Function
A	Ground
B	10-36 V DC input
C	<i>not connected</i>
D	<i>not connected</i>

Güralp Minimus
and Minimus+

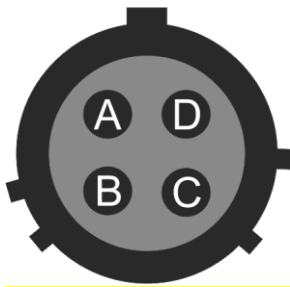

Wiring details for the compatible socket as seen from the cable end (*i.e.* when assembling).

Caution: Observe the correct polarity when connecting the power supply. The **red** lead (from pin B) must be connected to the **positive terminal**, typically labelled '+', and the **black** lead (from pin A) must be connected to the **negative terminal**, typically labelled '-'. An incorrect connection risks destroying the digitiser, the power supply and any connected instruments.

Caution: We recommend fitting an in-line 3.5 A anti-surge fuse in the positive power lead to protect the external wiring of the installation.

11.3 GNSS/serial

This is a 14-pin LEMO EEG.1K socket. Suitable mating connectors can be found in the LEMO FGG.1K.314 range.

- To engage the mating connector, line up the red marks and push firmly home.
- To disengage, hold the mating connector by the gnurled outer sleeve and pull steadily.



Pin	Function
1	Ground
2	<i>not connected</i>
3	Ground
4	Debug (serial) receive
5	Debug (serial) transmit
6	<i>not connected</i>
7	GNSS power
8	GNSS pulse-per-second signal – RS-422 positive
9	GNSS receive – RS-422 positive
10	GNSS transmit – RS-422 positive

Güralp Minimus
and Minimus+

11	GNSS transmit – RS-422 negative
12	<i>not connected</i>
13	GNSS pulse-per-second signal – RS-422 negative
14	GNSS receive – RS-422 negative



Wiring details for the compatible plug, FGG.1K.314.*, as seen from the cable end (*i.e.* when assembling).

11.4 Digital

This is a standard 10-pin military-specification bayonet sockets, conforming to MIL-DTL-26482 (formerly MIL-C-26482).



Pin	Function
A	Ground
B	Power
C	RS422 serial transmit – positive
D	RS422 serial transmit – negative
E	RS422 serial receive – negative
F	<i>not connected</i>
G	<i>not connected</i>
H	<i>not connected</i>
I	<i>not connected</i>
J	RS422 serial receive – positive

Güralp Minimus
and Minimus+



Wiring details for the compatible plug, ***-12-10P, as seen from the cable end (*i.e.* when assembling).

11.5 Analogue 1 and Analogue 2

These are standard 26-pin male military-specification bayonet plugs, conforming to MIL-DTL-26482 (formerly MIL-C-26482).



Pin	Function	Pin	Function
A	Vertical Acceleration/Velocity – differential non-inverting input	P	Calibration signal (all channels)
B	Vertical Acceleration/Velocity – differential inverting input	R	Calibration enable – vertical channel
C	N/S Acceleration/Velocity – differential non-inverting input	S	Calibration enable – N/S channel
D	N/S Acceleration/Velocity – differential inverting input	T	Calibration enable – E/W channel
E	E/W Acceleration/Velocity – differential non-inverting input	U	Centre
F	E/W Acceleration/Velocity – differential inverting input	V	Aux sensor input – differential non-inverting (or single) input
G	Vertical mass positions	W	Unlock
H	<i>not connected</i>	X	Lock
J	N/S mass positions	Y	Logic – ground*
K	<i>BUSY</i> line	Z	Sensor RS232 transmit
L	E/W mass positions	a	Sensor RS232 receive
M	Auxiliary sensor input – differential inverting input	b	Power – ground*

Güralp Minimus
and Minimus+

N	Signal – ground*	c	Power – positive
----------	------------------	----------	------------------

* “Power – ground” and “Logic – ground” are connected together internally and also connected to the digitizer case.



Wiring details for the compatible socket, ***-16-26S, as seen from the cable end (*i.e.* when assembling).

12 Appendix 4 – Dimensions and drawings

12.1 Minimus

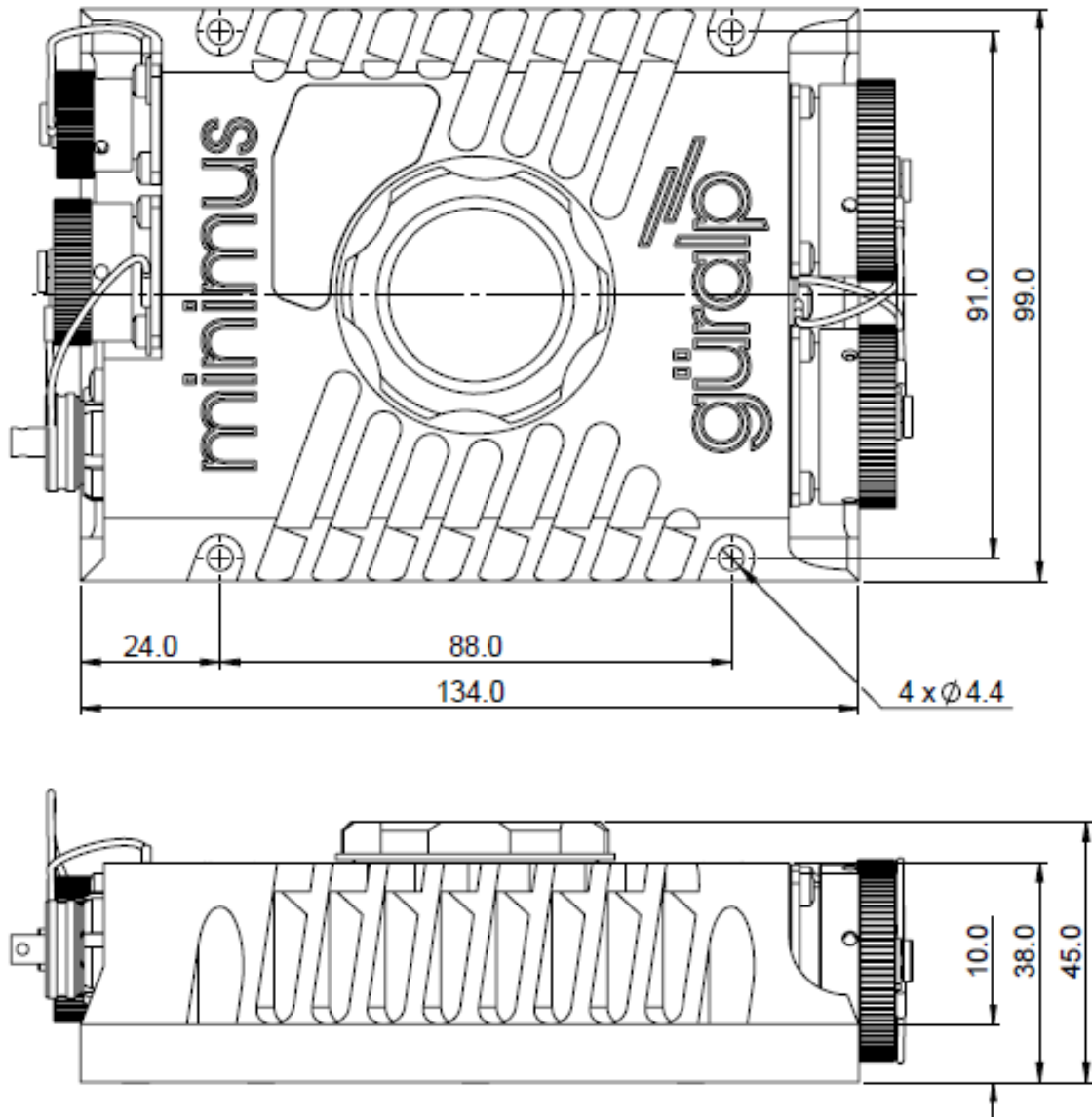

12.2 Minimus+

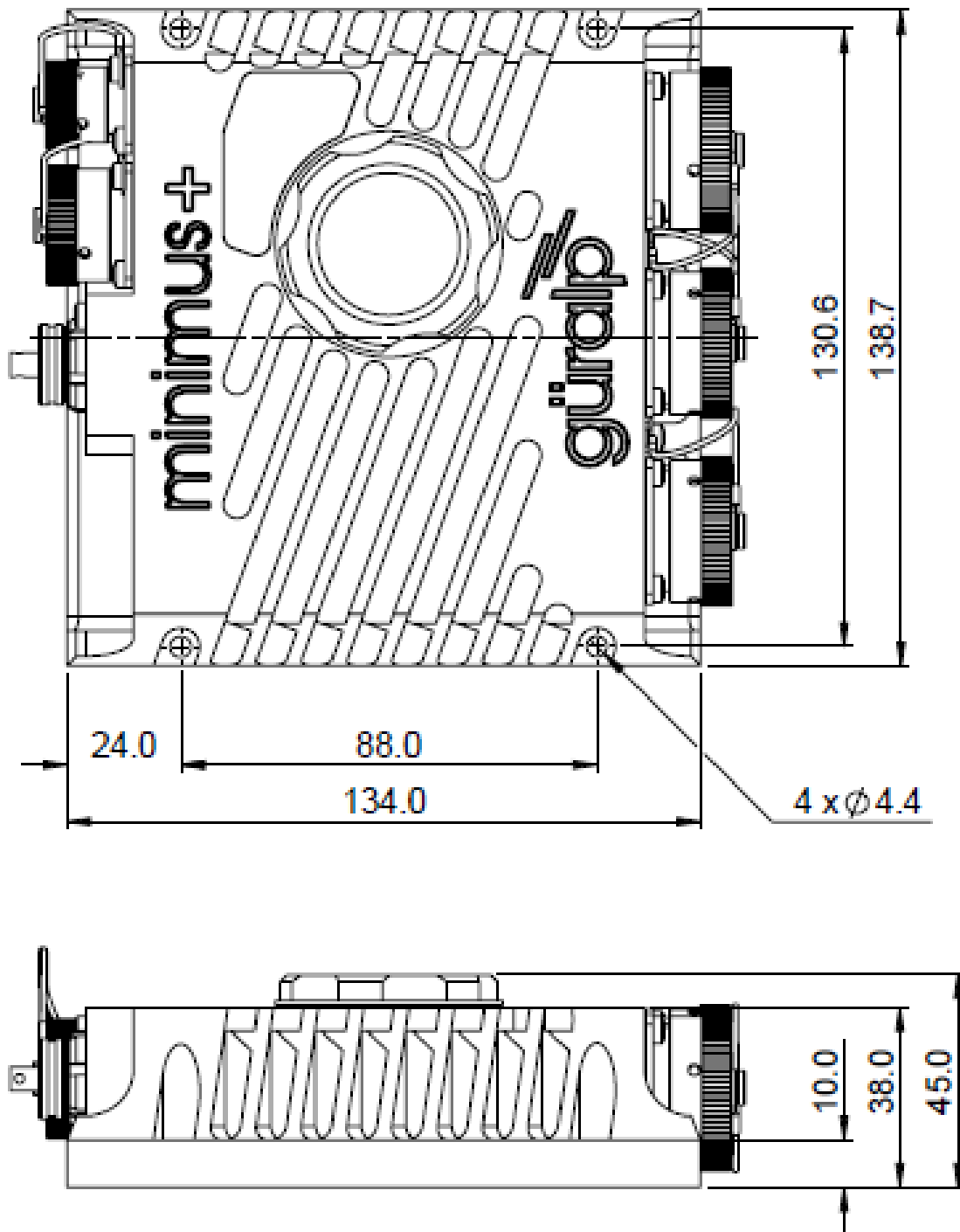

13 Appendix 5 – Güralp Discovery installation

Güralp Discovery is a software package for Microsoft Windows, MAC and Linux, which facilitates the identification, configuration and management of Güralp digitizers and instruments.

Güralp Minimus and Minimus+

Güralp Discovery has a conventional `.msi`-based installer. Once installed, the software can check whether it is the current version and can update itself using a button on the Help→About menu.

13.1 Installation in Linux

The Linux version of Discovery 64-bit is delivered in a self-contained package.

To install Güralp Discovery:

1. Open the terminal
2. Visit www.guralp.com/sw/download-discovery.shtml to download the appropriate installation script or use the command

```
wget http://www.guralp.com/download/discovery/Discovery.run
```

3. Make the downloaded file executable using the command

```
chmod +x Discovery.run
```

4. Run the script with the `-h` option to see the installer's help message:

```
./Discovery.run -h
```

```
Online installer for Guralp Systems Discovery application
```

```
Usage: ./Discovery.run [parameters]
```

```
Parameters:
```

```
-h : this message
```

```
-i : perform installation
```

```
-o <directory> : output directory (default /opt/guralp/discovery)
```

5. Execute the script, either accepting the default installation directory

```
./Discovery.run -i
```

or providing your own, alternative location

```
./Discovery.run -i -o /usr/lib/discovery
```

Güralp Minimus and Minimus+

The script proceeds through the following installation stages:

1. A confirmation prompt:

```
Guralp Discovery will be installed in: /opt/guralp/discovery. [C]ontinue/[A]bort
```

Type **C** to continue installation in listed directory, or **A** to abort and change directory using the `-o` execution parameter

2. Downloading. The following message is printed:

```
Downloading Discovery from Guralp Systems server [Downloading]
```

This step downloads the discovery package from the Güralp server. It is around 50 MiB in size so downloading may take a long time if you have a slow Internet connection.

3. Next, the following message is printed:

```
Creating installation directory: /opt/guralp/discovery [OK]
```

This step creates the installation directory. If an error occurs at this stage, please make sure that the user running the installation script has permission to create the specified directory.

4. The downloaded archive is now unpacked into the specified installation directory. The following message is printed:

```
Unpacking Discovery to /opt/guralp/discovery [OK]
```

5. The next step removes the downloaded file from the disk.

```
Removing downloaded Discovery archive [OK]
```

6. At this point, the installation is complete. The message

```
Discovery is now installed in: /opt/guralp/discovery/discovery
```

is displayed and the application is available in the specified directory.

13.2 Installation in Mac

To install Güralp Discovery in a macOS machine:

1. Open Safari, visit www.guralp.com/sw/download-discovery.shtml and download the appropriate disk-image file.

Güralp Minimus and Minimus+

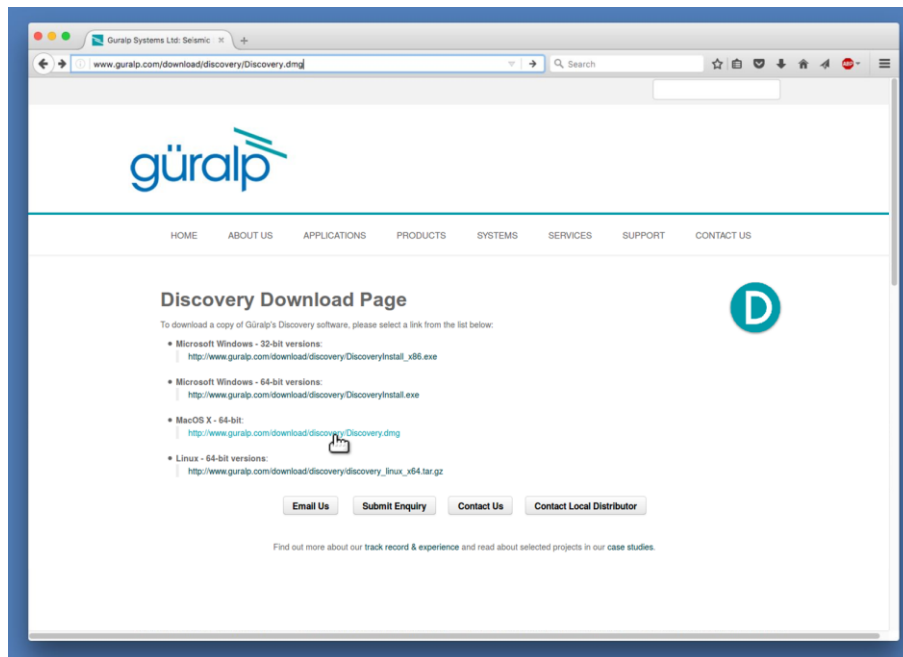

2. Either save the downloaded file on a local drive, or automatically open it with DiskImageMounter.

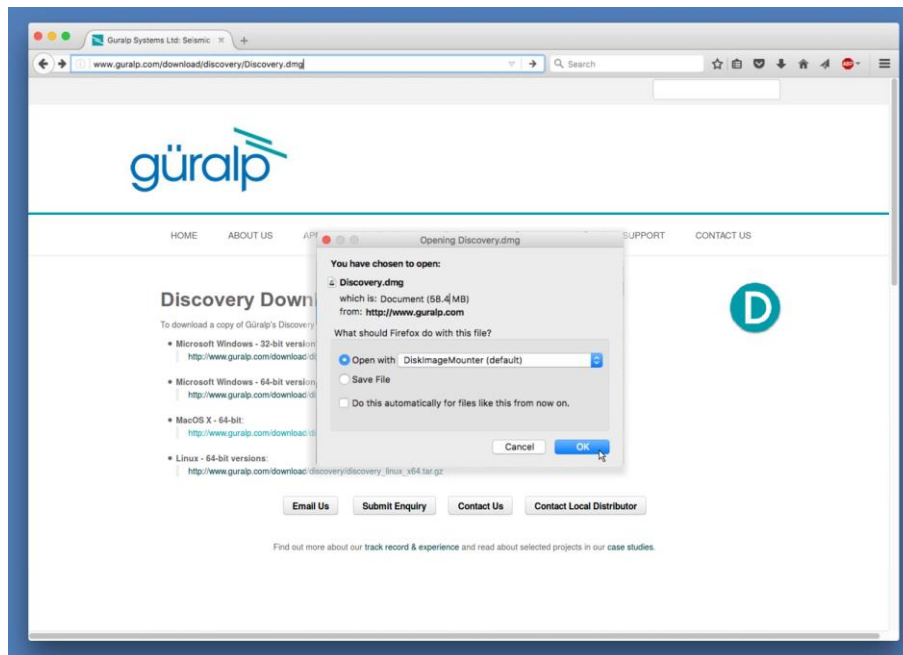

3. If you saved the file to disk, navigate to the download location and open Discovery.dmg with DiskImageMounter.
4. Successful mounting should result in Discovery drag and drop installation window

Güralp Minimus and Minimus+

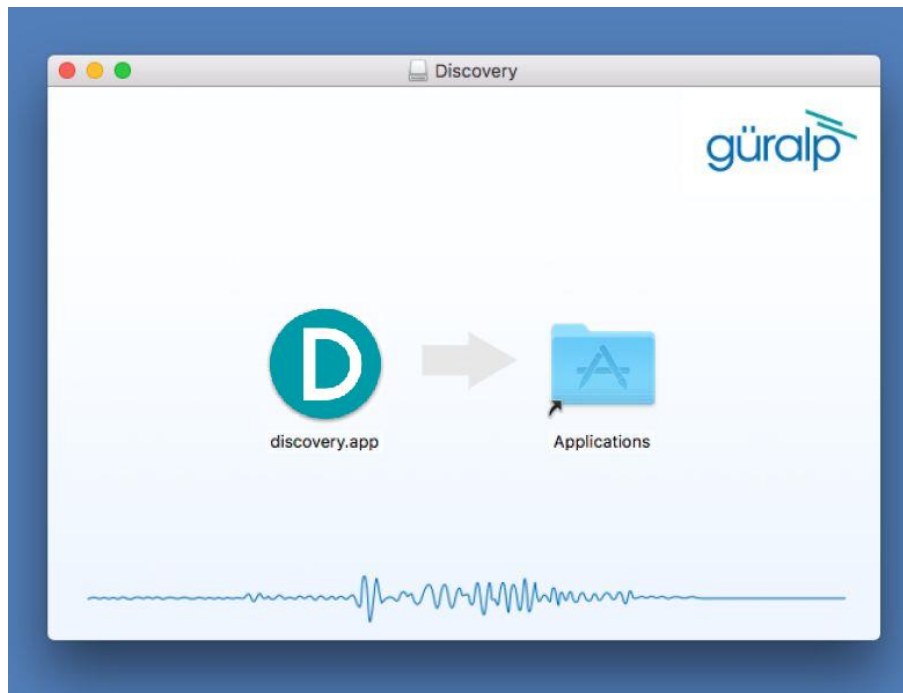

5. Drag and drop discovery.app to the Applications folder.
6. When finished, the installation is complete and the Discovery app can be found in Launcher or Applications folder in Finder.

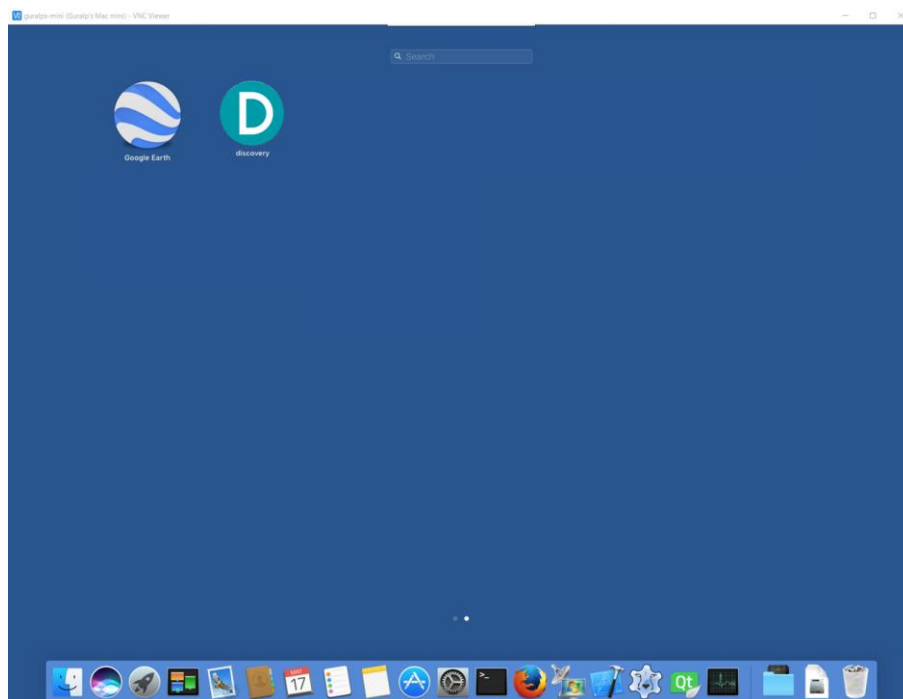

13.3 Installation in Windows

To install Güralp Discovery on a Windows machine:





1. Download the appropriate installer – 32-bit or 64-bit – from

Güralp Minimus and Minimus+

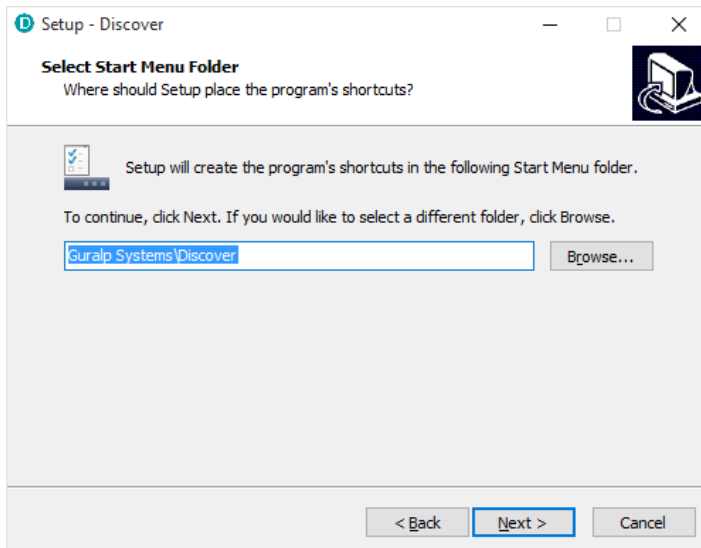
<https://www.guralp.com/sw/download-discovery.shtml>

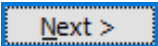
2. Double-click the downloaded file. You may be asked whether you wish to continue: answer yes.
3. The following screen asks where, in the Start Menu, you would like to place the Discovery short-cut. The default location is normally satisfactory but you can change it from here if you wish.



Click  key  or key  +  to continue.



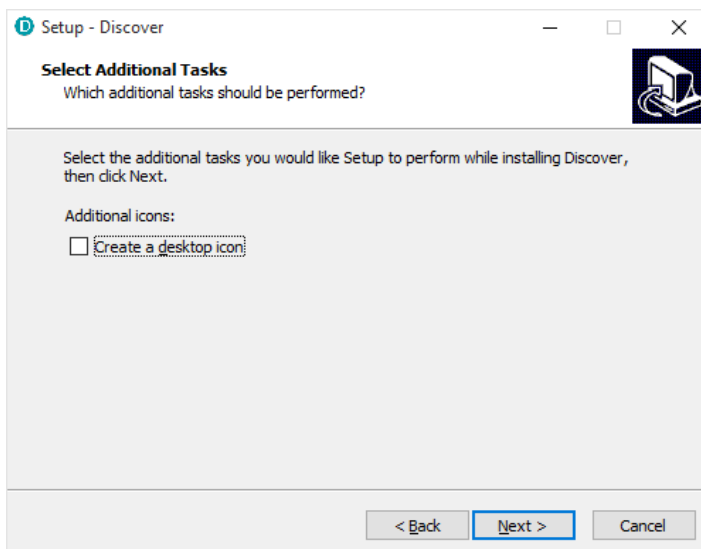



4. The next screen asks whether you would like to place an icon for Discovery on the desktop:

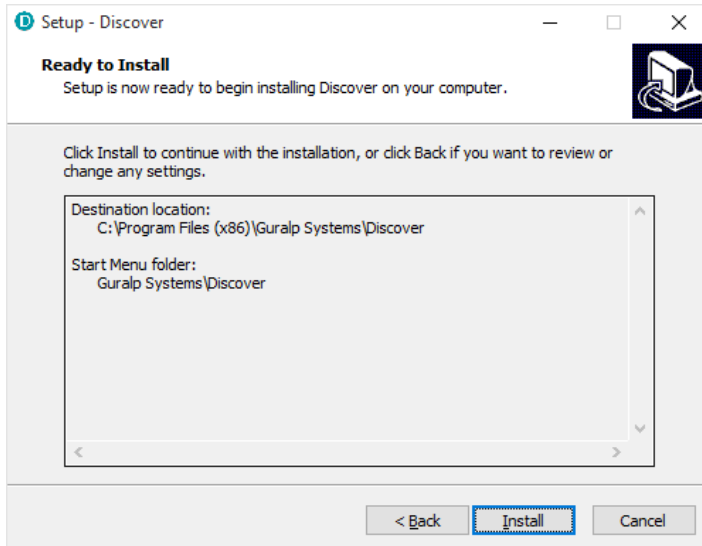

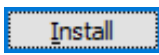
Tick the check-box if you wish and then click  key  or key  +  to continue.

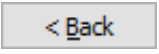

5. The installer then offers a last chance to change any of your decisions:

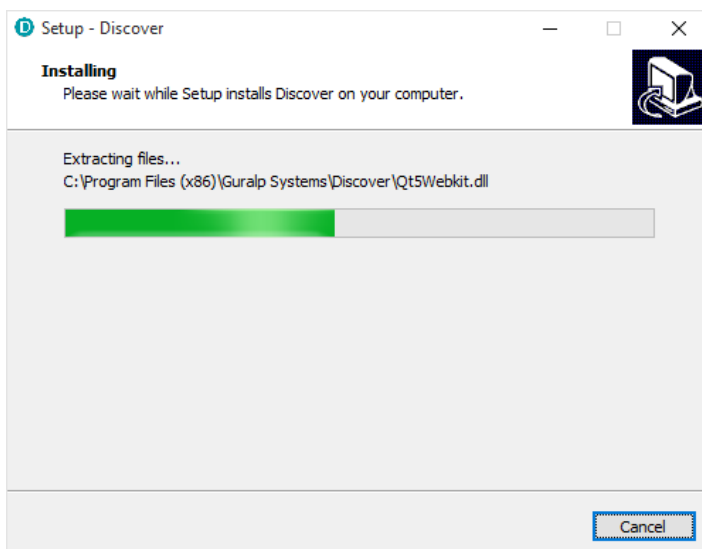

Click  key  or key  +  if you are happy with your choices or click  (or key  + ) if you wish to revisit any of them.

6. Once you have clicked , the installation begins and a progress screen is displayed:

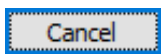

Pressing  or keying  now will remove all of the installed files (except the installer itself) and reverse any changes made so far.

7. Once installation is complete, the following screen is displayed:

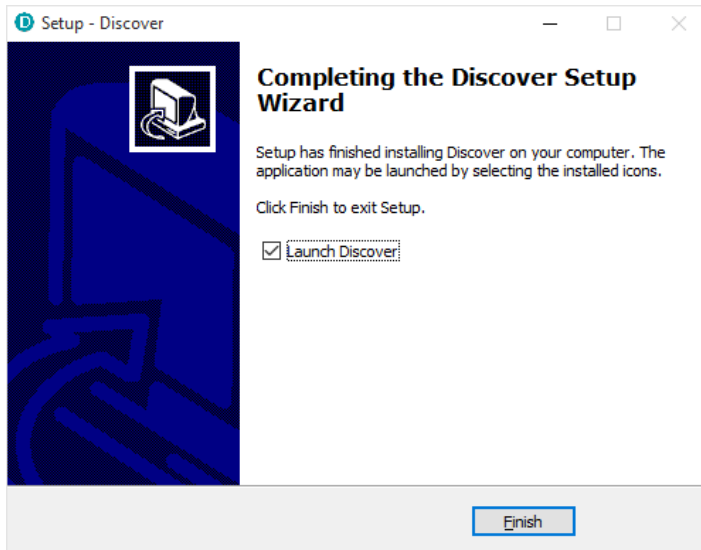

Press  key, key  or key  +  to close the installer and launch Discovery.

Note: Discovery for Windows 64-bit requires Microsoft Visual C++ 2015. Discovery may ask to install it if it is not installed yet.

13.4 Configuring Windows Firewall

Windows Firewall can interfere with Discovery's ability to send information to instruments and/or receive information from instruments over the network. If you use Windows Firewall, you should make special provision for allowing Discovery to communicate, as described in this section.

1. Click in the "Ask me anything" search box at the bottom left of your Windows screen:



2. Type “allow an app”

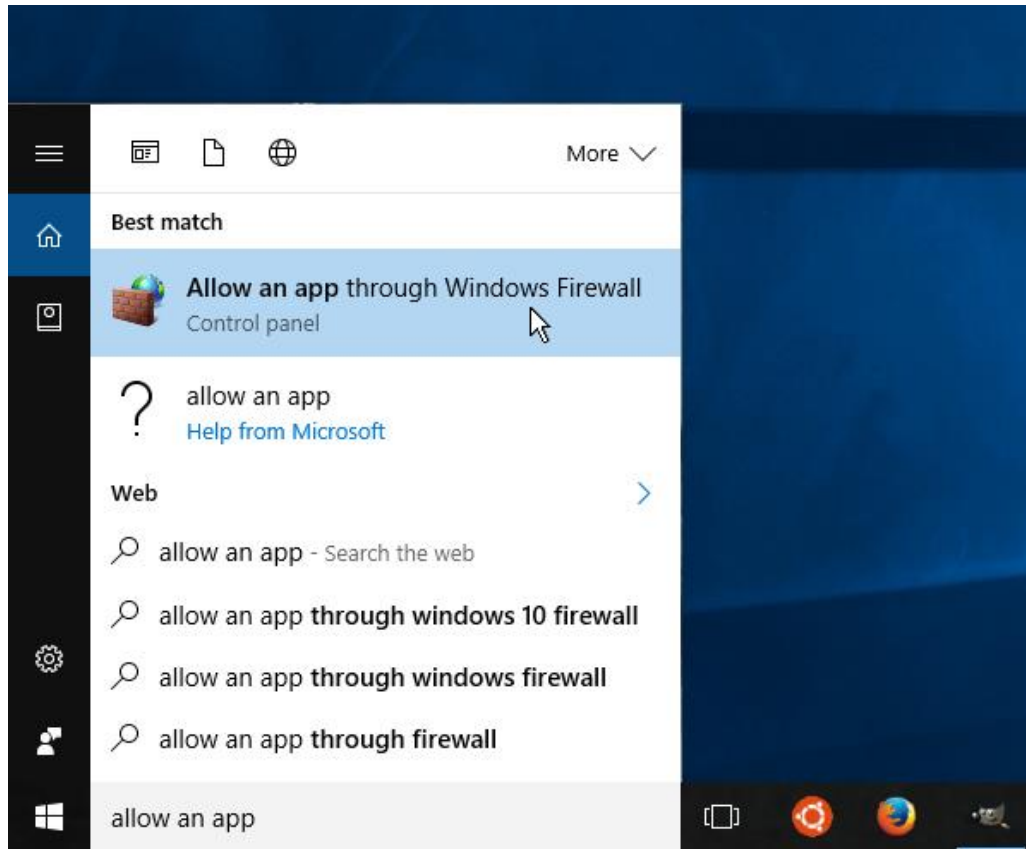

3. Select “Allow an app through Windows Firewall” from the search results.

4. Windows will display the “Windows Firewall Allowed Applications” screen.

This displays a list of applications in alphabetical order. Each application is provided with three check-boxes which indicate whether the application can communicate with networked devices in the “Domain” profile, the “Private” profile or the “Public” profile. (Profiles are also known as “network locations”.)

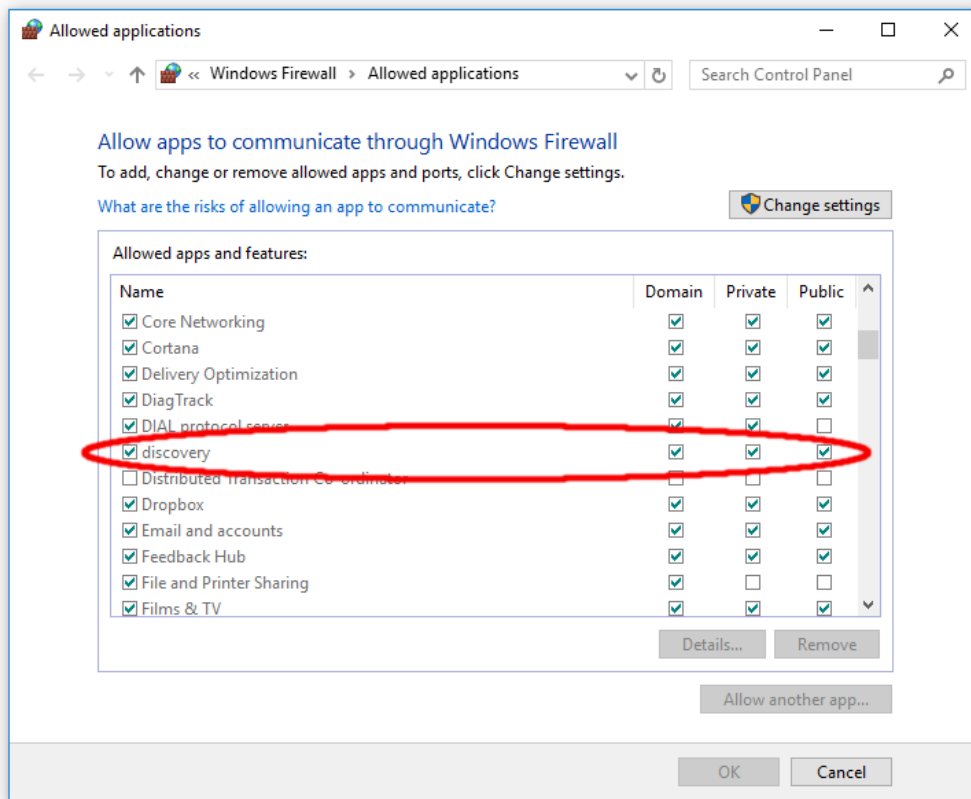

The “Domain” profile applies to networks where the host system can authenticate to a domain controller. The “Private” profile is a user-assigned profile and is used to designate private or home networks. The default profile is the “Public” profile, which is used to designate public networks such as Wi-Fi hotspots at coffee shops, airports, and other locations.

For a more complete discussion of this topic, please see <http://www.tenforums.com/tutorials/6815-network-location-set-private-public-windows-10-a.html> or your Windows documentation.

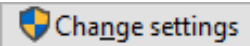
5. First click the  buttons to activate the interface.

- Highlight the “discovery” line and then click the **Details...** button. The “Edit an app” window is shown:

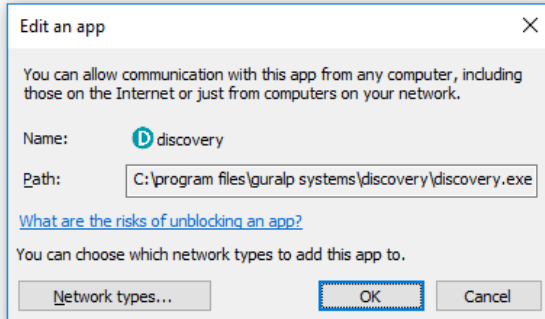

- Click the **Network types...** button. The “Choose network types” window is shown:

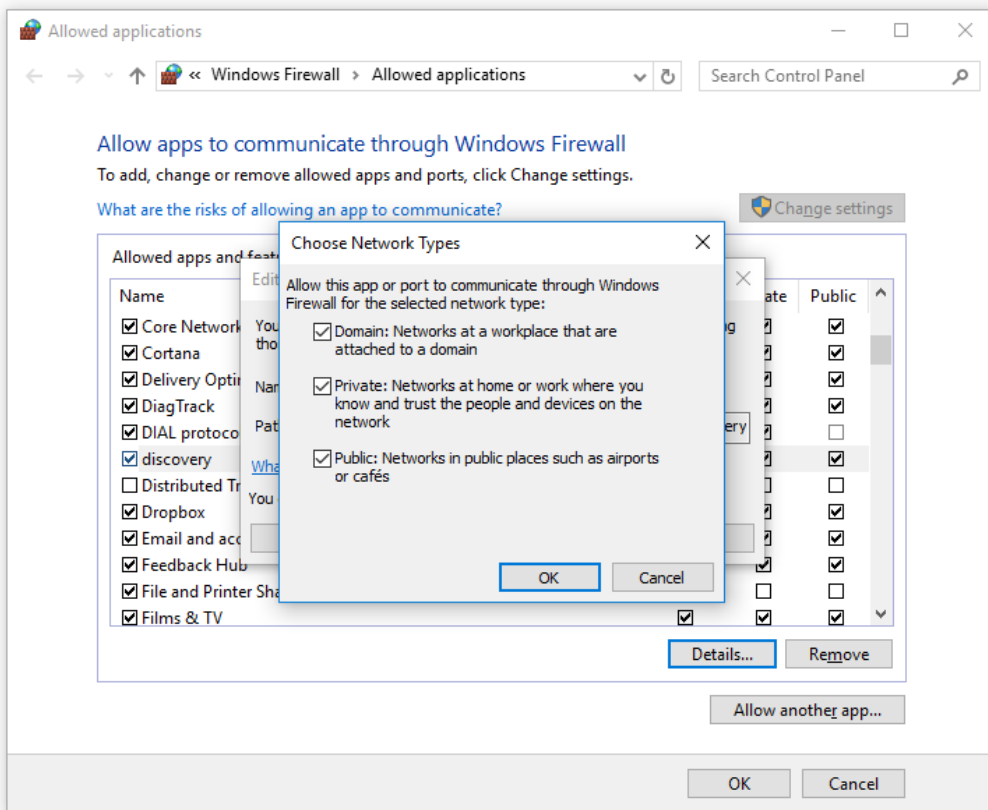

- After making appropriate changes, click **OK** first in the “Choose network types” window, then in the “Edit an app” window, then in the “Windows Firewall Allowed Applications”. This closes the Windows Firewall “Allowed Applications” tool and saves the changes that you have made.

Güralp Minimus and Minimus+

13.5 Update

If a PC running Güralp Discovery has an Internet connection, Discovery can check whether an update is available. To initiate this, click About from the Help menu or

type **Alt** + **H** followed by **A**:

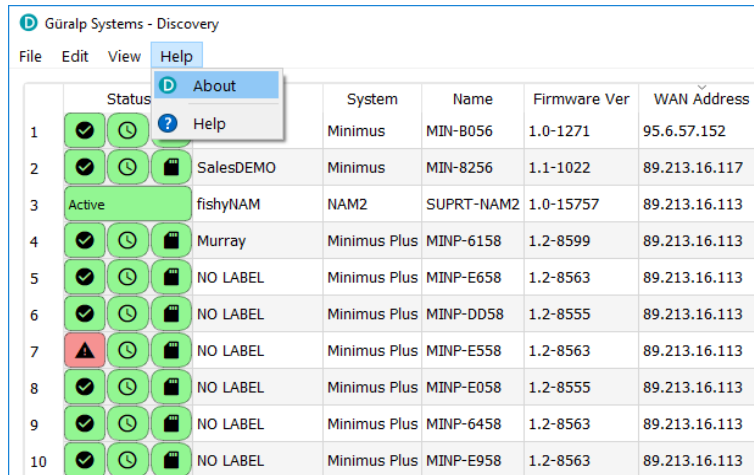

	Status		System	Name	Firmware Ver	WAN Address		
1				Minimus	MIN-B056	1.0-1271	95.6.57.152	
2				SalesDEMO	Minimus	MIN-8256	1.1-1022	89.213.16.117
3	Active			fishyNAM	NAM2	SUPRT-NAM2	1.0-15757	89.213.16.113
4				Murray	Minimus Plus	MINP-6158	1.2-8599	89.213.16.113
5				NO LABEL	Minimus Plus	MINP-E658	1.2-8563	89.213.16.113
6				NO LABEL	Minimus Plus	MINP-DD58	1.2-8555	89.213.16.113
7				NO LABEL	Minimus Plus	MINP-E558	1.2-8563	89.213.16.113
8				NO LABEL	Minimus Plus	MINP-E058	1.2-8555	89.213.16.113
9				NO LABEL	Minimus Plus	MINP-6458	1.2-8563	89.213.16.113
10				NO LABEL	Minimus Plus	MINP-E958	1.2-8563	89.213.16.113

A screen like the following is displayed:

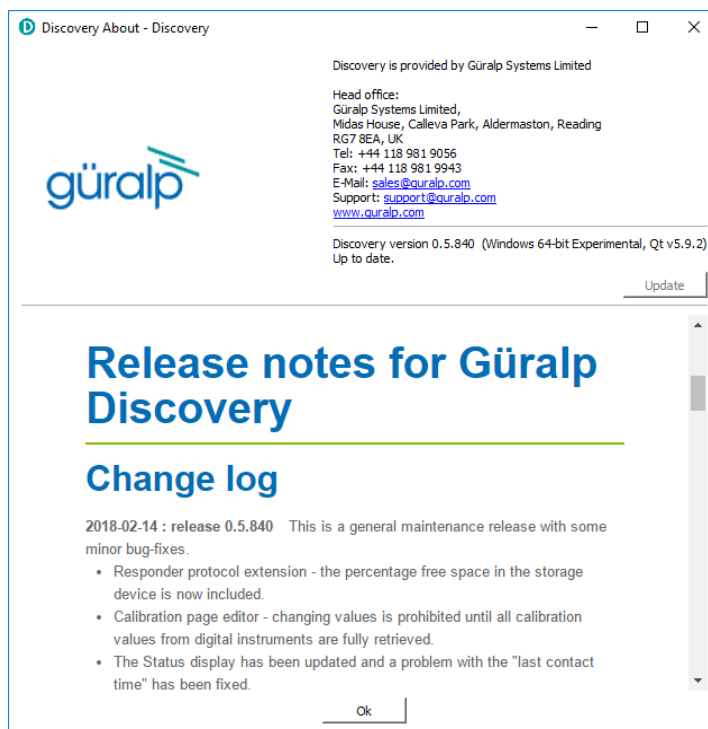

The currently installed version is shown. If this is the most recent version available, the screen will say Up to date and the **Update** button will be disabled, as shown above. If a newer version is available, the screen will look like this:

Güralp Minimus and Minimus+

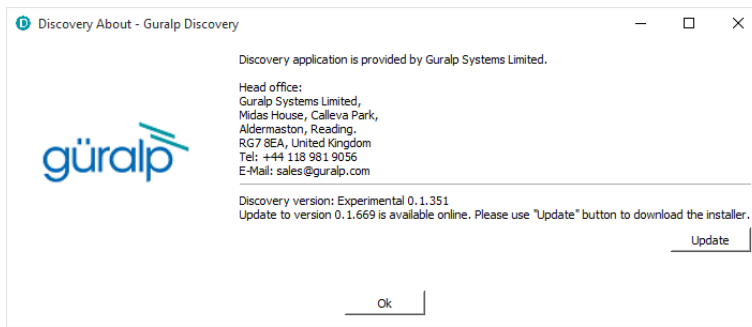

If you wish to proceed with downloading the newer version, click the **Update** button. This does not commit to an immediate upgrade: it just downloads the installer. If you do not wish to download the installer, click **Ok** to close the “Discovery About” dialogue.

If you clicked **Update**, you may see the following warning if the previous installer is still in your download folder:

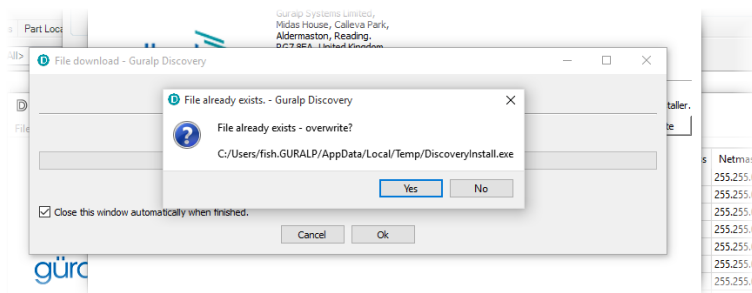

Simply click **Yes** or key **Enter** to continue: the download will start immediately.

While the download is in progress, the following indicator will be displayed:

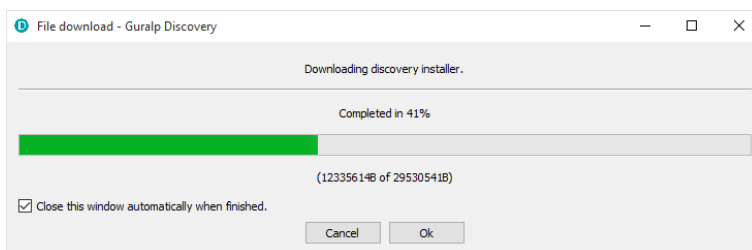

When the download is complete, the following screen is displayed:

Güralp Minimus and Minimus+

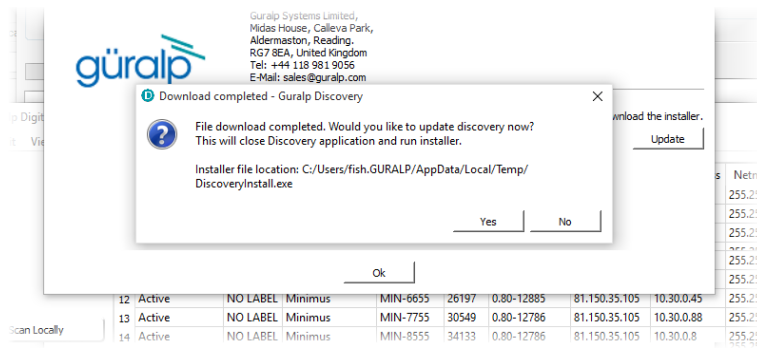

If you wish to complete the installation immediately, click Yes. If you would rather defer the installation, click No and run the installer at a more convenient time.

Once the upgrade is complete, start Discovery in the usual way. Windows, recognising that the program has changed, may ask you to specify how you wish Discovery to interact with the Windows Firewall. Because Discovery requires network communication in order to function, it is important that you understand the options available.

The following screen is displayed:

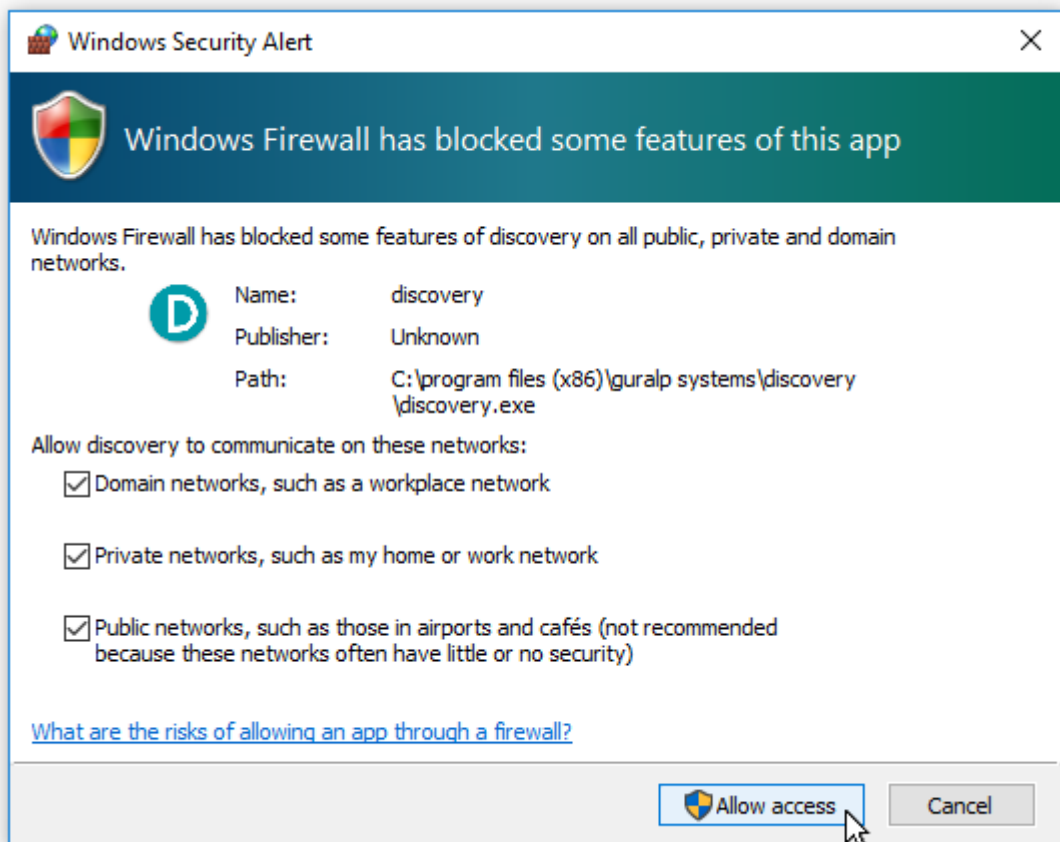

Güralp Minimus and Minimus+

The screen provides three check-boxes which indicate whether Discovery can communicate with networked devices in the “Domain” profile, the “Private” profile or the “Public” profile. (Profiles are also known as “network locations”.)

The “Domain” profile applies to networks where the host system can authenticate to a domain controller. The “Private” profile is a user-assigned profile and is used to designate private or home networks. The default profile is the “Public” profile, which is used to designate public networks such as Wi-Fi hotspots at coffee shops, airports, and other locations.

For a more complete discussion of this topic, please see www.tenforums.com/tutorials/6815-network-location-set-private-public-windows-10-a.html or your Windows documentation.

14 Appendix 6 – I.P. address configuration on PC or Laptop

With APIPA (Automatic Private I.P. Addressing), a laptop or PC can automatically configure itself with an I.P. address in the range 169.254.0.1 to 169.254.255.254. The default subnet mask is 255.255.0.0.

Connect the Minimus to the laptop or PC using the blue Ethernet cable and power it up.

14.1 On Linux

On your Linux computer, open the terminal and type the command

```
sudo bash
```

Key  and provide the appropriate password. Then, enter the command

```
ifconfig
```

to identify the Ethernet network interface to which the Minimus is connected. Once you have identified the correct interface, connect the Minimus, power it up and enter the commands

```
ifconfig wlp2s0 down
```

```
ifconfig wlp2s0 up
```

replacing `wlp2s0` with the name of the appropriate interface on your PC.

Enter the command `ifconfig` again to verify that the IPv4 address of the Ethernet adapter is now included in the network 169.254.0.0/16 - *i.e.* the address begins 169.154....

Güralp Minimus and Minimus+

```
wlp2s0 flags=4163<UP,BROADCAST,RUNNING,MULTICAST> mtu 1500
inet 169.254.139.29 netmask 255.255.0.0 broadcast 169.254.255.255
ether 94:65:9c:ab:3c:9a txqueuelen 1000 (Ethernet)
RX packets 556837 bytes 722823565 (689.3 MiB)
RX errors 0 dropped 0 overruns 0 frame 0
TX packets 320424 bytes 42811910 (40.8 MiB)
TX errors 0 dropped 0 overruns 0 carrier 0 collisions 0
```



In the example above, the interface has been allocated address 169.254.139.29, which is in the correct network.

14.2 On macOS

Click the Apple icon in the upper-left corner of the screen, and select "System Preferences."

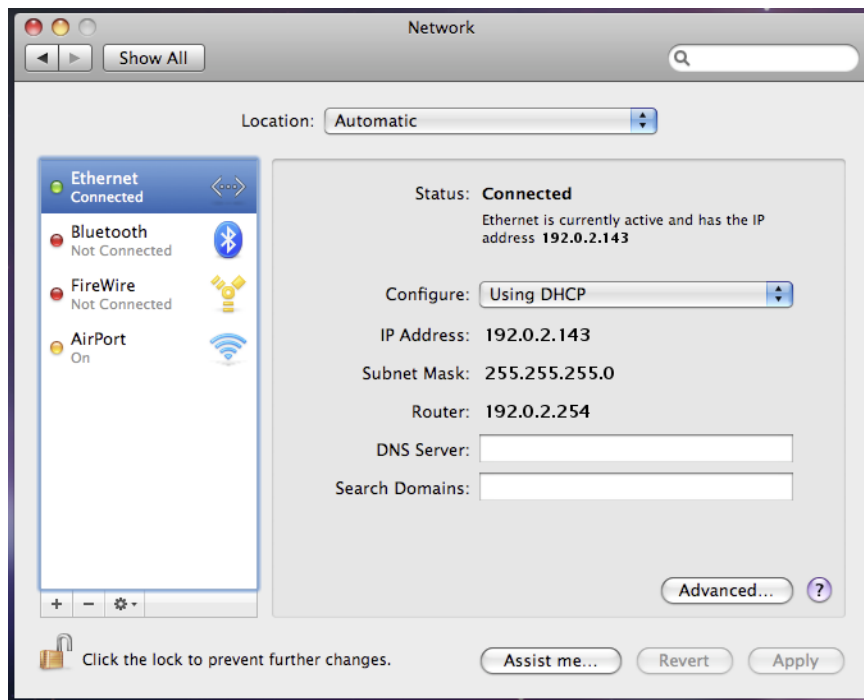
1. Click the "Network" icon to open the Network Preferences pane and select "Ethernet" from the list on the left side of the window.



2. Click the gear button, , in the lower-left corner of the window, then click "Make Service Inactive." Click the "Apply" button to disable the NIC (Network Interface Card).
3. With the Minimus connected and powered up, click the  button again, click "Make Service Active" and click "Apply" to re-enable the NIC.



Güralp Minimus and Minimus+

4. Check that the interface has been assigned an address in the correct network:





In the example above, the interface has been allocated address 169.254.56.230, which is in the correct network.

14.3 On Windows

On a Windows computer, key  +  to open the "Run" dialogue, enter `ncpa.cpl` and key .

Right-click on the network adapter which is connected to the Minimus and select "Disable" from the context menu. Right-click on the same adapter again and select "Enable". Close the network settings window.

Key  +  and type `cmd.`, then . This opens a command window. Type the command `ipconfig` and verify that the IPv4 address of the Ethernet adapter is included in network `169.254.*.*`.

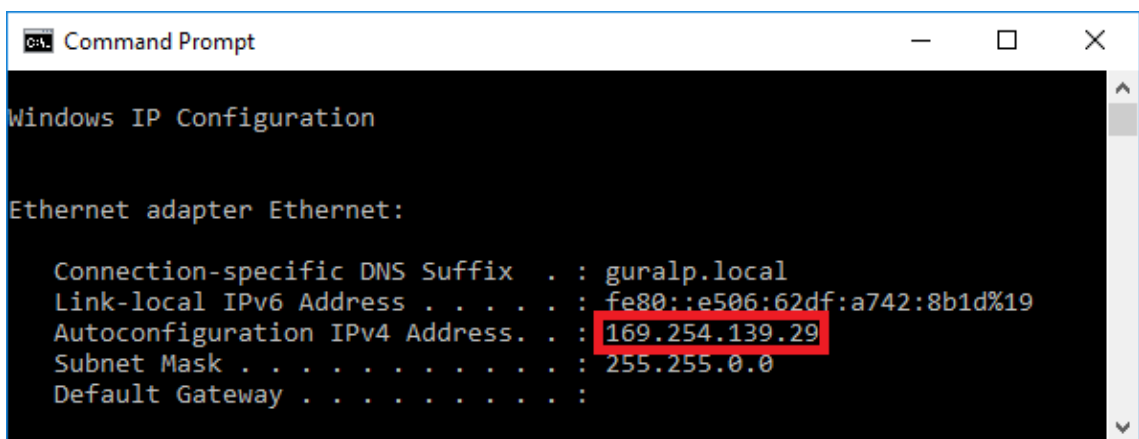

In the example above, the interface has been allocated address 169.254.56.230, which is in the correct network.

15 EU Declaration of Conformity

We

Guralp Systems Ltd
Midas House, Calleva Park, Aldermaston
READING, RG7 8EA.



Tel: +44 118 981 9056
E-mail: technical@guralp.com

Declare under our sole responsibility that the following product

Equipment name: Minimus and Minimus+ with GPS
Model Number: MI-2407SA0V20124 and MI-2414SA0V20643 and appropriate variants

Is in conformity with the

Radio Equipment Directive 2014/53/EU
Electromagnetic Compatibility Directive 2014/30/EU
Low Voltage Directive 2014/35/EU
Restriction of Hazardous Substances (RoHS) Directive 2011/65/EU

by applying the following harmonised standards and technical specifications:

EN 55011, EN 55016:2009 +A1:2010 – Conducted Emissions
EN 55011, EN 55032 :2009 +A1:2010 – Radiated Emissions
EN 61000-4-2:2009 – Electrostatic Discharge Immunity
EN 61000-4-3:2006 +A1:2008 +A2:2010 – Radiated RF Immunity
EN 61000-4-4:2012 – Electrical Fast Transients Immunity
EN 61000-4-5:2014 – Voltage Surge Immunity
EN 61000-4-6:2014 – Conducted RF Immunity
EN 61000-4-8:2010 – Power Frequency Magnetic Field Immunity
IEC 61010-1 3rd Edition - Low voltage Safety
2011/65/EU – RoHS

Signed for and on behalf of
Guralp Systems Ltd
on 25 February 2020

Systems Director

A handwritten signature in black ink, appearing to read 'M. Minus', is located below the text 'Systems Director'.

16 Revision History

Q	2021-09-09	Added EU Declaration of Conformity
M	2019-12-02	Updated LED sequence. Updated web page screen-shots. Updated Data Stream and Data Storage. Updated stream and file names. Updated and added Transforms. Updated EEW and Triggering. Added back-fill from miscoSD card.
L	2018-09-02	Added details of new-style microSD card-holder Moved NTP to Network section and corrected description.
K	2018-08-14	Updated web page screen-shots Updated I.P. address section Added modified SEEDlink Added QSCD protocol and transform Added Seismic Events Table Added case drawings
J	2018-06-25	Updated Discovery screen-shots. Updated Scream file-name. Updated LiveView screen-shots. Updated Calibration Page Editor. Updated Setup tab. Updated EEW settings. Updated LED behaviour. Updated storage tab. Updated formatting instructions. Updated channel names. Updated firmware update procedure. Updated troubleshooting. Added analogue sensor calibration. Added transforms. Added miniSEED extractor. Added note on non-recording status. Added Minimus default static I.P. address info. Added instructions for setting PC I.P. address. Added local access from the Registry. Added recommendation on sensor grounding. Removed FPGA firmware update.
H	2018-03-19	Added LEMO connector warning.
G	2018-02-16	Included Minimus+.

Güralp Minimus
and Minimus+

		Updated Discovery screen-shots. Updated Discovery software download instructions (incorporating new download page). Updated SEEDlink server options. Updated STA/LTA Ratio threshold. Updated GDI channels name. Updated Minimus firmware upgrade procedure. Added column hide/show in Discovery. Added Control Centre. Added Deploy mode section. Added PTP.
F	2017-07-28	Updated EEW and triggering section. Updated calibration page editor. Added FPGA firmware update. Added GDI connection settings. Added network setting in Discovery. Added Power tab section. Added Minimus ports.
E	2017-05-19	Updated Discovery and GüVü print screens. Updated Discovery and GüVü download links. Updated calibration section. Updated analogue pin-out. Added MEMS axis directions. Added download of data from web page. Added EEW and triggering section. Added GDI auto-connection section. Added installation instructions for MAC and Linux
D	2017-02-09	Updated Discovery print screens. Corrected Analogue and Digital pin-outs Corrected GDI channels name.
C	2016-11-15	Corrected power connector gender. Extra detail for Ethernet connector. Added Windows Firewall details. Added microSD-card removal details.
B	2016-09-20	Brought up-to-date with current firmware release. Updated stream names. Added SEED-link information. Added system reset function during boot.
A	2016-08-24	Initial release.